

KENWOOD

SERVICE MANUAL

700/800MHz DIGITAL TRANSCEIVER

NX-5900, NX-5900(B)

NX-5900 is a model that operation panel is attached.
NX-5900(B) is a model that operation panel is not attached.
The illustration is NX-5900.

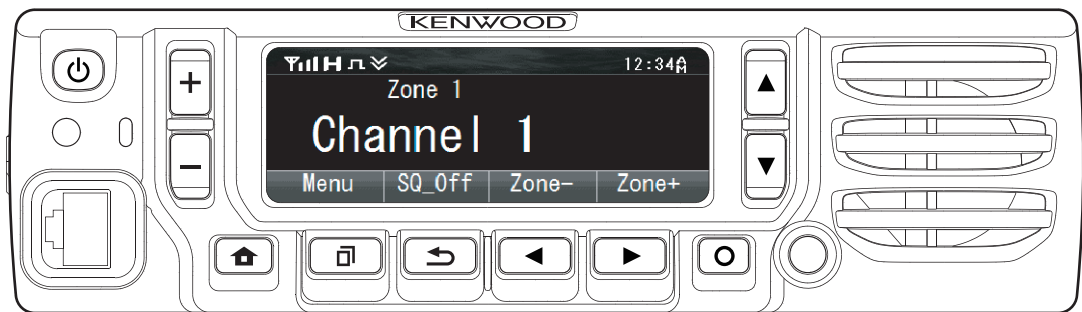

TABLE OF CONTENTS

1	PRECAUTION.....	1-4
2	SPECIFIC SERVICE INSTRUCTIONS.....	1-4
3	DISASSEMBLY.....	1-31
4	ADJUSTMENT.....	1-34
5	TROUBLESHOOTING.....	1-76

This product complies with the **RoHS** directive for the European market.



This product uses Lead Free solder.

Document Copyrights

Copyright 2015 by JVC KENWOOD Corporation. All rights reserved.

No part of this manual may be reproduced, translated, distributed, or transmitted in any form or by any means, electronic, mechanical, photocopying, recording, or otherwise, for any purpose without the prior written permission of JVC KENWOOD Corporation.

Disclaimer

While every precaution has been taken in the preparation of this manual, JVC KENWOOD Corporation assumes no responsibility for errors or omissions. Neither is any liability assumed for damages resulting from the use of the information contained herein.

JVC KENWOOD Corporation reserves the right to make changes to any products herein at any time for improvement purposes.

Firmware Copyrights

The title to and ownership of copyrights for firmware embedded in KENWOOD product memories are reserved for JVC KENWOOD Corporation. Any modifying, reverse engineering, copy, reproducing or disclosing on an Internet website of the firmware is strictly prohibited without prior written consent of JVC KENWOOD Corporation. Furthermore, any reselling, assigning or transferring of the firmware is also strictly prohibited without embedding the firmware in KENWOOD product memories.

Transceivers containing AMBE+2™ Vocoder:

The AMBE+2™ voice coding technology is embedded in the firmware under the license of Digital Voice Systems, Inc.

Bluetooth Copyrights

The Bluetooth® word mark and logos are registered trademarks owned by Bluetooth SIG, Inc. and any use of such marks by JVC KENWOOD Corporation is under licence. Other trademarks and trade names are those of their respective owners.

NOTE

- This equipment should be serviced by only qualified technicians.
- Danger of explosion if the battery is incorrectly replaced; replace only with the same type.
- To dispose of batteries, be sure to comply with the laws and regulations in your country or region.

SPECIFICATION

GENERAL		
Frequency Range	Receive	763~776, 851~870 MHz
	Transmit	763~776, 793~806, 806~825, 851~870 MHz
Max. Channels per Radio		1024 (Up to 4000 CH with option)
Number of Zones		128
Max. Channels per Zone		512
Channel Spacing	Analog	12.5 / 25 kHz
	Digital	6.25 / 12.5 kHz
Operating Voltage		13.6V DC \pm 15%
Operating Temperature Range		-22°F to +140°F (-30°C to +60°C)
Frequency Stability		\pm 1.0ppm
Dimensions (W x H x D)	Radio w/Control Head	6.73 x 1.89 x 7.72 in. (171 x 48 x 196 mm)
Weight (net)	Radio w/Control Head	3.75 lbs (1.7 kg)
RECEIVER		
Sensitivity	NXDN 6.25kHz Digital (3%BER)	0.20 μ V
	NXDN 12.5kHz Digital (3%BER)	0.25 μ V
	P25 Digital (5% BER)	0.25 μ V
	P25 Digital (1% BER)	0.40 μ V
	Analog (12dB SINAD)	0.25 μ V
Selectivity	P25 Digital	63dB
	Analog @ 12.5kHz	70dB
	Analog @ 25kHz	78dB
Intermodulation		80dB
Spurious Rejection		85dB
Audio Distortion		Less than 2%
Audio Output		4W / 4 Ω (Remote Control Head: 3W / 4 Ω)
TRANSMITTER		
RF Power Output		30W to 2W (700M), 35W to 2W (800M)
Spurious Emission		-80dB
FM Hum & Noise	Analog @ 12.5kHz	40dB
	Analog @ 25kHz	45dB
Audio Distortion		Less than 2%
Modulation		16K0F3E, 14K0F3E, 11K0F3E, 8K10F1E, 8K10F1D, 8K10F1W, 8K30F1E, 8K30F1D, 8K30F7W, 4K00F1E, 4K00F1D, 4K00F7W, 4K00F2D

Analog measurements made per TIA 603 and specifications shown are typical.

P25 Digital measurements made per TIA 102CAAA and specifications shown are typical.

JVC KENWOOD Corporation reserves the right to change specifications without prior notice or obligation.

SECTION 1 PRECAUTION

This service manual does not describe PRECAUTION.

SECTION 2 SPECIFIC SERVICE INSTRUCTIONS

2.1 SYSTEM SET-UP

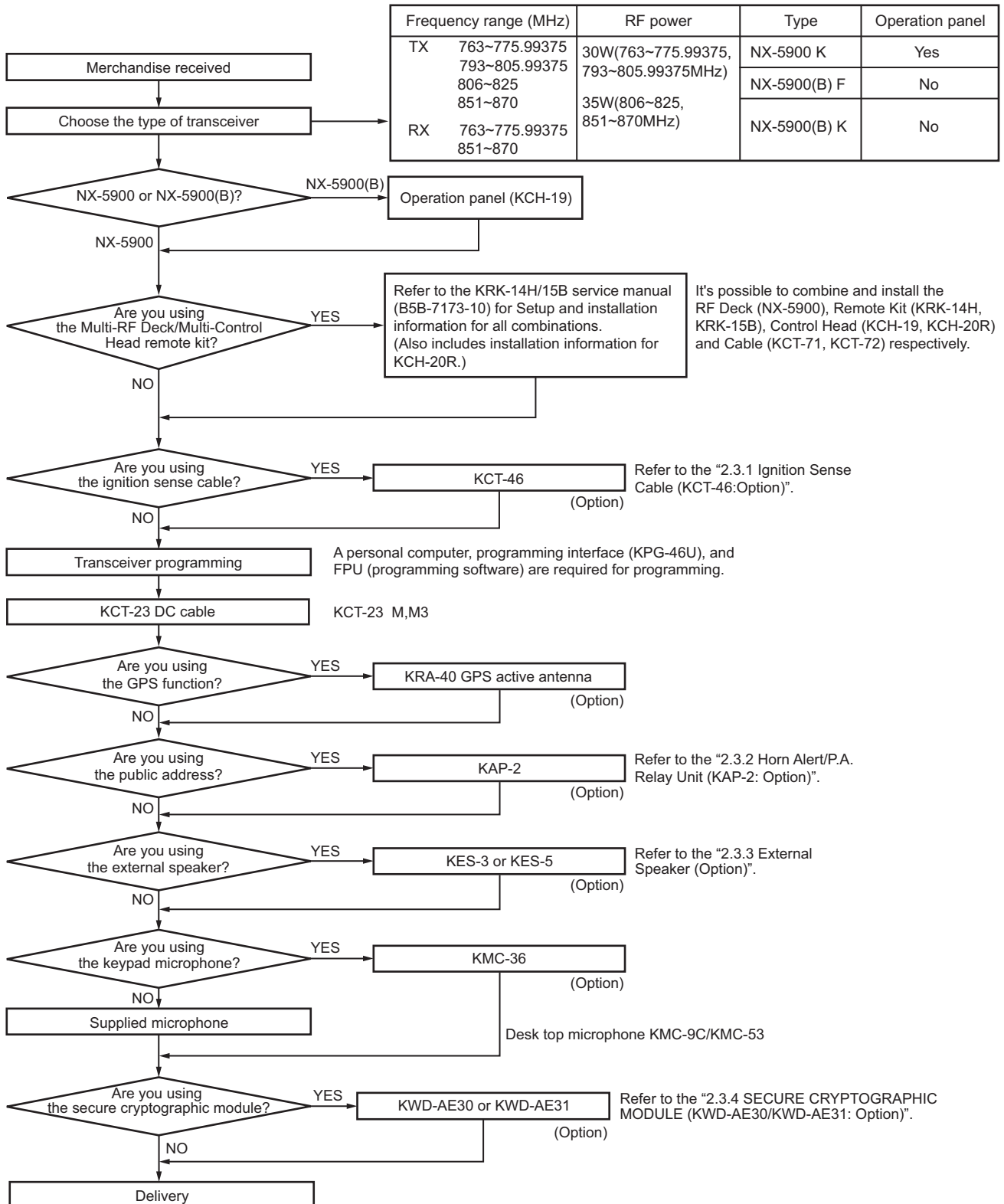

2.2 REALIGNMENT

2.2.1 Modes

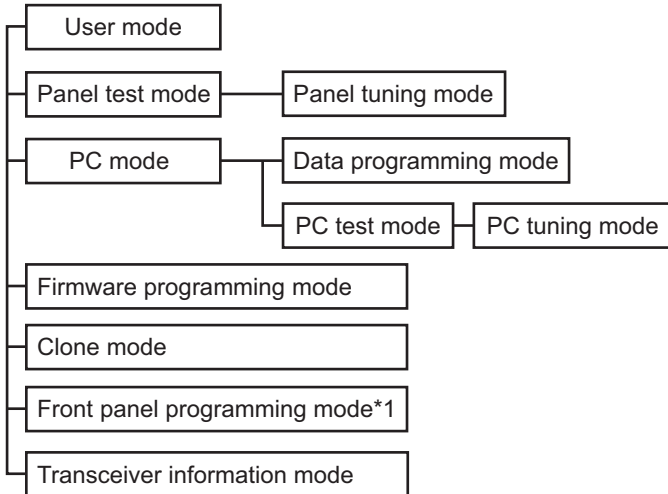

*1: In order to use the Front panel programming mode, it is necessary to purchase the "Front panel program" feature option.

Mode	Function
User mode	For normal use.
Panel test mode	Used by the dealer to check the fundamental characteristics.
Panel tuning mode	Used by the dealer to tune the transceiver.
PC mode	Used for communication between the transceiver and PC.
Data programming mode	Used to read and write frequency data and other features to and from the transceiver.
PC test mode	Used to check the transceiver using the PC. This feature is included in the FPU.
Firmware programming mode	Used when changing the main program of the flash memory.
Clone mode	Used to transfer programming data from one transceiver to another.
Front panel programming mode	Frequency, signaling and features write to the transceiver.
Transceiver information mode	Used to confirm the transceiver firmware version, SCM firmware version and SCM Hardware version.

2.2.2 How to Enter Each Mode

Mode	Operation
User mode	Power ON
Panel test mode*2	<ul style="list-style-type: none"> • [↩] + Power ON • [] + Power ON Select the "Panel Test" using the [▲] / [▼] key. Press the [] key.
PC mode	Received commands from PC
Panel tuning mode	[Panel test mode] + []

Mode	Operation
Firmware programming mode*2	<ul style="list-style-type: none"> • [AUX (Orange)] + Power ON • [] + Power ON Select the "Firmware Prog" using the [▲] / [▼] key. Press the [] key. • If Write is performed by KFL, Firmware programming mode will start automatically.
Clone mode*2	<ul style="list-style-type: none"> • [] + Power ON • [] + Power ON Select the "Clone" using the [▲] / [▼] key. Press the [] key.
Front panel programming mode*2	<ul style="list-style-type: none"> • Press the PF key to which Front panel programming mode is set during the user mode. • Press the [] key and enter the Menu mode. Select the any icon assigned the Front panel programming mode using the [▲] / [▼] key. Press [] key. Select the "Panel Program" using the [▲] / [▼] key. Press the [] key.
Transceiver information mode*2	<ul style="list-style-type: none"> • [+] + Power ON • [] + Power ON Select the "Transceiver Info" using the [▲] / [▼] key. Press the [] key.

*2 There is the two or three as how to enter.

2.2.3 Panel Test Mode

Setting method refer to ADJUSTMENT.

2.2.4 Panel Tuning Mode

Setting method refer to ADJUSTMENT.

2.2.5 PC Mode

2.2.5.1 Preface

The transceiver is programmed by using a personal computer, programming interface (KPG-46U/46X) and FPU (programming software).

The programming software can be used with a PC. Figure 1 shows the setup of a PC for programming.

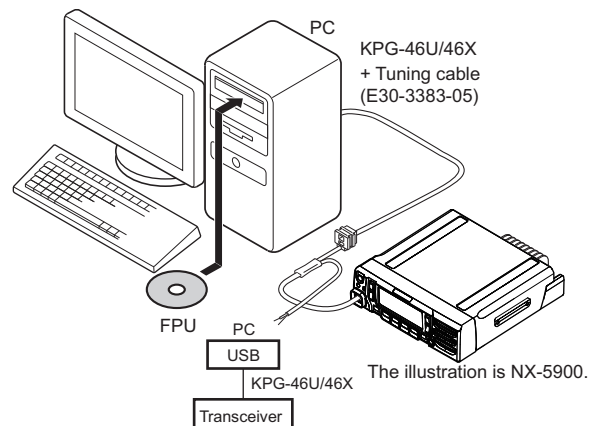

Fig.1

2.2.5.2 Connection procedure

- (1) Connects the transceiver to the computer using the interface cable (KPG-46U/46X).

Note:

You must install the KPG-46U/46X driver in the computer to use the USB programming interface cable (KPG-46U/46X).

- (2) When the POWER switch on, user mode can be entered immediately. When PC sends command the transceiver enter PC mode, and "PROGRAM" is displayed on the LCD. When data transmitting from the transceiver, the red LED lights. When data receiving to the transceiver, the green LED lights.

Note:

The data stored in the computer must match the "Model Name" when it is written into the flash memory.

2.2.5.3 KPG-46U/46X description (USB programming interface cable: Option)

The KPG-46U/46X is a cable which connects to a USB port on a computer.

When using the KPG-46U/46X, install the supplied CD (with driver software) in the computer. The KPG-46U driver runs under Windows XP, Vista, 7, 8 or 8.1.

The KPG-46X driver runs under Windows Vista, 7, 8 or 8.1.

The latest version of the USB driver is available for download from the following URL:

<http://www.kenwood.com/usb-com/>

(This URL may change without notice.)

2.2.5.4 Programming software KPG-D1/D1N (Ver. 1.60 or later) description

The FPU is the programming software for the transceiver supplied on a CD. This software runs under Windows Vista, 7, 8 or 8.1 on a PC.

The data can be input to or read from the transceiver and edited on the screen.

2.2.6 Firmware Programming Mode

2.2.6.1 Preface

Flash memory is mounted on the transceiver. This allows the transceiver to be upgrade when new features are released in the future. (For details on how to obtain the firmware, contact Customer Service.)

2.2.6.2 Connection procedure

Connect the transceiver to the personal computer using the programming interface (KPG-46U/46X). (Connection is same as in the PC mode.)

2.2.6.3 Programming

- (1) Start up the firmware programming software (KENWOOD Firmware Loader). The KFL.exe exists in the KPG-D1/D1N installed folder.
- (2) Set the baud rate to "auto" or 1152000, 576000, 115200, and 57600.
- (3) Set the firmware to be upgrade by file name item.
- (4) Enter the Firmware programming mode by using section "2.2.2 How to Enter Each Mode". Then, the yellow LED on the transceiver light and "FIRMWARE PROG" is displayed.
- (5) Check the connection between the transceiver and the personal computer, and make sure that the transceiver is in the Program mode.
- (6) Press "Write" button in the window. When the transceiver starts to receive data, the "LOADING" display lights.



- (7) If writing ends successfully, the checksum is calculated and a result is displayed.

- (8) If you want to continue programming other transceivers, repeat step (4) to (7).

Note:

If write is performed by KFL, Firmware programming mode will start automatically even if Firmware programming is set to disable in the programming software.

2.2.6.4 Function

If you press the [] key while "FIRMWARE PROG" is displayed, the checksum is calculated, and a result is displayed. If you press the [] key again while checksum is displayed, "FIRMWARE PROG" is redisplayed.



2.2.7 Clone Mode

Programming data can be transferred from one transceiver to another by connecting them via their modular microphone jacks. The operation is as follows.

■The following data cannot be cloned.

- Tuning data
- Embedded message with password
- ESN (Electronic Serial Number) data

■Key guide on the Clone/ Front Panel Programming Password input screen.

- Confirm ([] key): The password confirmation
- Delete ([] key): Delete the latest digit from the current password number (Press and hold to delete all password numbers)
- Select([] key): Determine the latest digit of the password number.

- (1) In the source transceiver, enter the clone mode by using section "2.2.2 How to Enter Each Mode". When the Clone/ Front Panel Programming Password is set to the transceiver, "Input Password" is displayed on the LCD. If the password is not set, the transceiver displays "CLONE MODE".

- (2) When you enter the correct password, "CLONE MODE" is displayed, the transceiver can be used as the cloning source. The following describes how to enter the password.

- (3)

- How to enter the password using the MIC keypad;



If one of the keys 0 to 9 is pressed while the "Input Password" is displayed, the password number is displayed on the LCD.

Each press of the key shifts the display in order to the left.



When you enter the password and press [] or [*] key, "CLONE MODE" displayed if the entered password is correct. If password is incorrect, "Input Password" is redisplayed.

- How to enter password using the [▲] and [▼] keys;

If the [▲] / [▼] key is pressed while "Input Password" is displayed, the Clone/ Front Panel Programming Password input screen is displayed.

If the [▲] or [▼] key is pressed while the clone/ Front Panel Programming Password input screen is displayed, the number (0 to 9) blinks on the LCD. When you press the [] key, currently selected number is determined. If you press the [] key after entering password in this procedure, "CLONE MODE" is displayed if entered pass-

word is correct. If the password is incorrect, "Input Password" is redisplayed.

- (4) Power ON the target transceiver.
- (5) Connecting the cloning cable (part No.E30-3382-05) to the modular microphone jacks on the source and target.
- (6) Press [] key on the source while the source displays "CLONE MODE". The data of the source is sent to the target. While the target is receiving the data, "PROGRAM" is displayed. When cloning of the data is completed, the source displays "END", and the target automatically operates in the User mode. The target can then be operated by the same program as the source.
- (7) The other target can be continuously cloned. When the [] key on the source is pressed while the source displays "END", the source displays "CLONE MODE". Carry out the operation in step (4) to (6).

Note:

- Cannot be cloned if the password (overwrite password) is programmed to the target.
- "Model name" must be same to clone the transceiver.

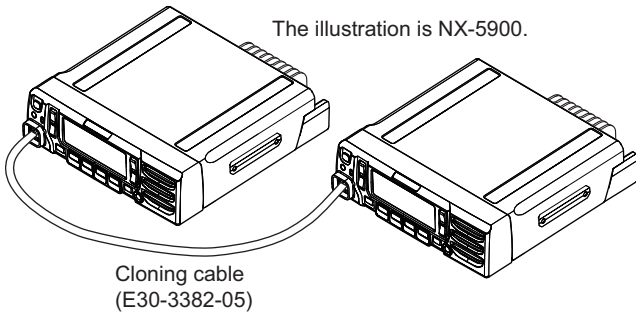

Fig.2

2.2.8 Front Panel Programming Mode



If the Front Panel Programming Mode is used, the frequency or other data of the conventional channel is rewritable only by the transceiver.

Moreover, the conventional channel can be added.

■The following setup items can be changed or added by using the Front panel programming mode.

- RX/TX Frequency
- Channel Type
- Channel Spacing
- Decode QT/DQT/RAN/NAC, Encode QT/DQT/RAN/NAC
- Talkgroup ID List No.
- Transmit Power
- Channel Name

■Key guide on the Clone/ Front Panel Programming Password input screen.

- Confirm ([] key): The password confirmation
- Delete ([] key): Delete the latest digit from the current password number (Press and hold to delete all password numbers)
- Select ([] key): Determine the latest digit of the password number.

2.2.8.1 Enter to the Front panel programming mode.

Enter to the Menu Mode by pressing [Front Panel Mode] PF key or [Menu] key. When the Front Panel Mode is selected, it can enter to the Front panel programming mode.

If the Clone/Front panel programming Password is not set to the transceiver, "Panel Program" is displayed on the LCD.

If the Clone/Front panel programming Password is set to the transceiver, "Panel Program" is displayed on the LCD when you enter the correct password while "Input Password" is displayed.

2.2.8.2 Data Writing

Before moving to next Zone/Channel, "Keep This Change?" appears on the LCD, if you select "OK", the new data is written to memory. If you select "Cancel", the new data not be written; the new data will be erased.

- The setup items for Front panel programming mode are as follows.

No.	Setup item	Display	Remarks
1	RX Frequency	RX Frequency	Receive Frequency
2	TX Frequency	TX Frequency	Transmit Frequency
3	Channel Type	Channel Type	Analog/NXDN/P25
4	Channel Spacing	Channel Space	Analog: 12.5kHz/25kHz
			NXDN: 6.25kHz/12.5kHz
			P25: 12.5kHz
5	RX Signaling	RX QT/DQT	Receive QT/DQT
6	TX Signaling	TX QT/DQT	Transmit QT/DQT
7	RX RAN	RX RAN	None, 1~63
8	TX RAN	TX RAN	None, 1~63
9	RX NAC	RX NAC	000~FFF (Hexadecimal) Note: "F7F" cannot set.
10	TX NAC	TX NAC	000~FFF (Hexadecimal) Note: "F7E" and "F7F" cannot set.
11	Talkgroup ID List Number	Talkgroup	None, 1~1500
12	Transmit Power	Transmit Power	Low/Medium/High
13	Channel Name	Channel Name	

• Key operation

Key/Item	Zone Select	Channel Select	RX Frequency	TX Frequency	Channel Type	Channel Spacing	RX Signaling	TX Signaling
[□]	Decision	Decision	Decision	Decision	Decision	Decision	Decision	Decision
[←]	Unused	Back to the previous item	Back to the previous item	Back to the previous item	Back to the previous item	Back to the previous item	Back to the previous item	Back to the previous item
[○]	Unused	Unused	Unused	TX Frequency OFF	Unused	Unused	Unused	Unused
[⏏]	Exit panel program mode	Exit panel program mode	Exit panel program mode	Exit panel program mode	Exit panel program mode	Exit panel program mode	Exit panel program mode	Exit panel program mode
[▲]	Zone change	Channel change	Frequency up	Frequency up	Channel type change	Channel Spacing Change	Signaling number change	Signaling number change
[▼]	Zone change	Channel change	Frequency down	Frequency down	Channel type change	Channel Spacing Change	Signaling number change	Signaling number change
[▶]	Unused	Unused	Frequency step change	Frequency step change	Unused	Unused	Signaling type change	Signaling type change
[◀]	Unused	Unused	Frequency step change	Frequency step change	Unused	Unused	Signaling type change	Signaling type change
MIC Keypad [0] ~ [9]	Zone number select	Channel number select	Go to the direct enter mode		Channel number select (1 or 2)	Channel spacing select (1 or 2)	Go to the direct enter mode	
MIC Keypad [*]	Decision	Decision	Decision	Decision	Decision	Decision	Decision	Decision
MIC Keypad [#]	Unused	Back to the previous item	Back to the previous item	Back to the previous item	Back to the previous item	Back to the previous item	Back to the previous item	Back to the previous item

Key/Item	RX RAN	TX RAN	RX NAC	TX NAC	TG ID List No.	Transmit Power	Channel Name
[□]	Decision	Decision	Decision	Decision	Decision	Decision	Decision
[←]	Back to the previous item	Back to the previous item	Back to the previous item	Back to the previous item	Back to the previous item	Back to the previous item	Back to the previous item/Delete
[○]	Unused	Unused	Unused	Unused	Unused	Unused	Character/Digit switching
[⏏]	Exit panel program mode	Exit panel program mode	Exit panel program mode	Exit panel program mode	Exit panel program mode	Exit panel program mode	Exit panel program mode
[▲]	RX RAN up	TX RAN up	RX NAC up	TX NAC up	TG List number up	Transmit power change	Go to the direct enter mode
[▼]	RX RAN down	TX RAN down	RX NAC down	TX NAC down	TG List number down	Transmit power change	
[▶]	RX RAN ON/OFF	RX RAN ON/OFF	Unused	Unused	Unused	Unused	
[◀]	RX RAN ON/OFF	RX RAN ON/OFF	Unused	Unused	Unused	Unused	
MIC Keypad [0] ~ [9]	Go to the direct enter mode				Talkgroup List number select	Transmit power select (1, 2 or 3)	
MIC Keypad [*]	Decision	Decision	Decision	Decision	Decision	Decision	Decision/ Character/ Digit switching
MIC Keypad [#]	Back to the previous item	Back to the previous item	Back to the previous item	Back to the previous item	Back to the previous item	Back to the previous item	Back to the previous item

• Direct enter mode

Key/Item	RX Frequency	TX Frequency	RX Signaling	TX Signaling	RX RAN	TX RAN	RX NAC	TX NAC	Channel Name
[☐]	Decision								Character/Channel name decision
[↵]	Delete								
[○]	Unused								
[🏠]	Exit panel program mode								
[▲]	Unused								Character selection (upper case character → lower-case character → digit → upper case character...)
[▼]									Character selection (upper case character → lower-case character → digit → upper case character...)
[▶]									Move a cursor to the right
[◀]									Move a cursor to the left
MIC Key-pad [0] ~ [9]	Add a digit to the current number								
MIC Key-pad [*]	Decision								Input character switching
MIC Key-pad [#]	Delete/Back to the previous item								Delete

• Front panel programming mode flow chart

NX-5900

• Front panel programming mode flow chart

Enter the Front panel programming mode by using section "2.2.2 How to Enter Each Mode".

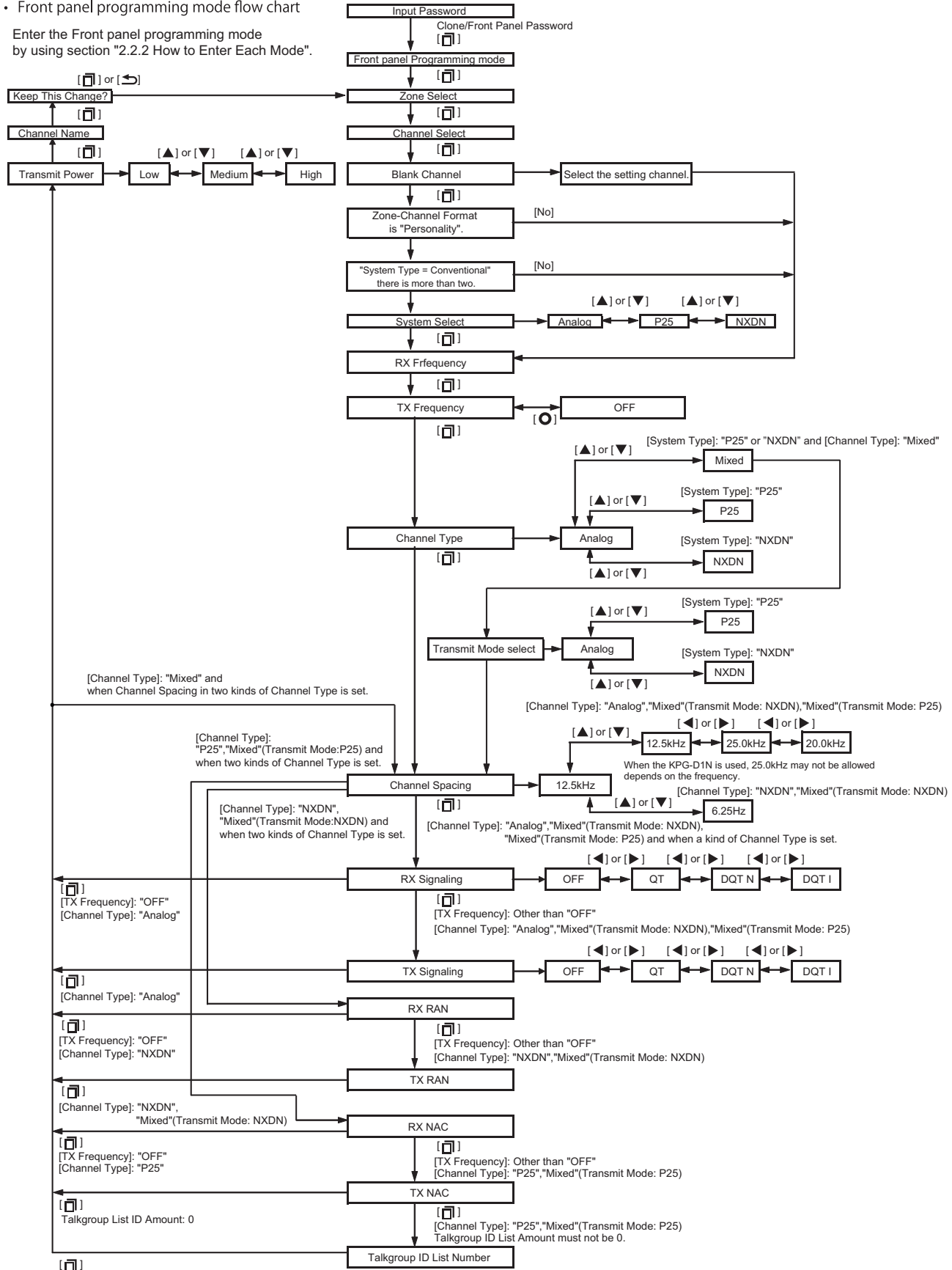

Note: Zone-Channel Format allows you to whether to configure for each zone the channels in the same system, or channels in different system. P25 can be configured for System Select or Channel Type if one or more P25 conventional system is preconfigured by the FPU.

2.2.9 Transceiver Information Mode

Use this function to confirm the transceiver firmware version, SCM Firmware version and SCM Hardware version.

- (1) Enter the Transceiver Information mode by using section "2.2.2 How to Enter Each Mode".
- (2) The transceiver firmware version appears on the LCD.
- (3) Use the [▲] and [▼] keys to select the confirmation items.

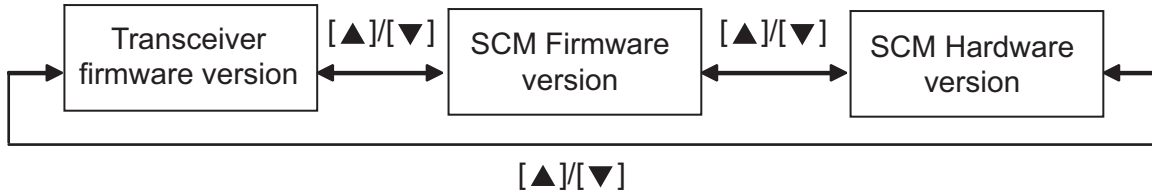

- (4) To exit the transceiver information mode, turn the transceiver power OFF.

Note:

When the SCM board is not equipped to the transceiver, SCM Firmware Version and SCM Hardware Version are displayed as "-.-.-."

2.3 INSTALLATION

NX-5900 External View

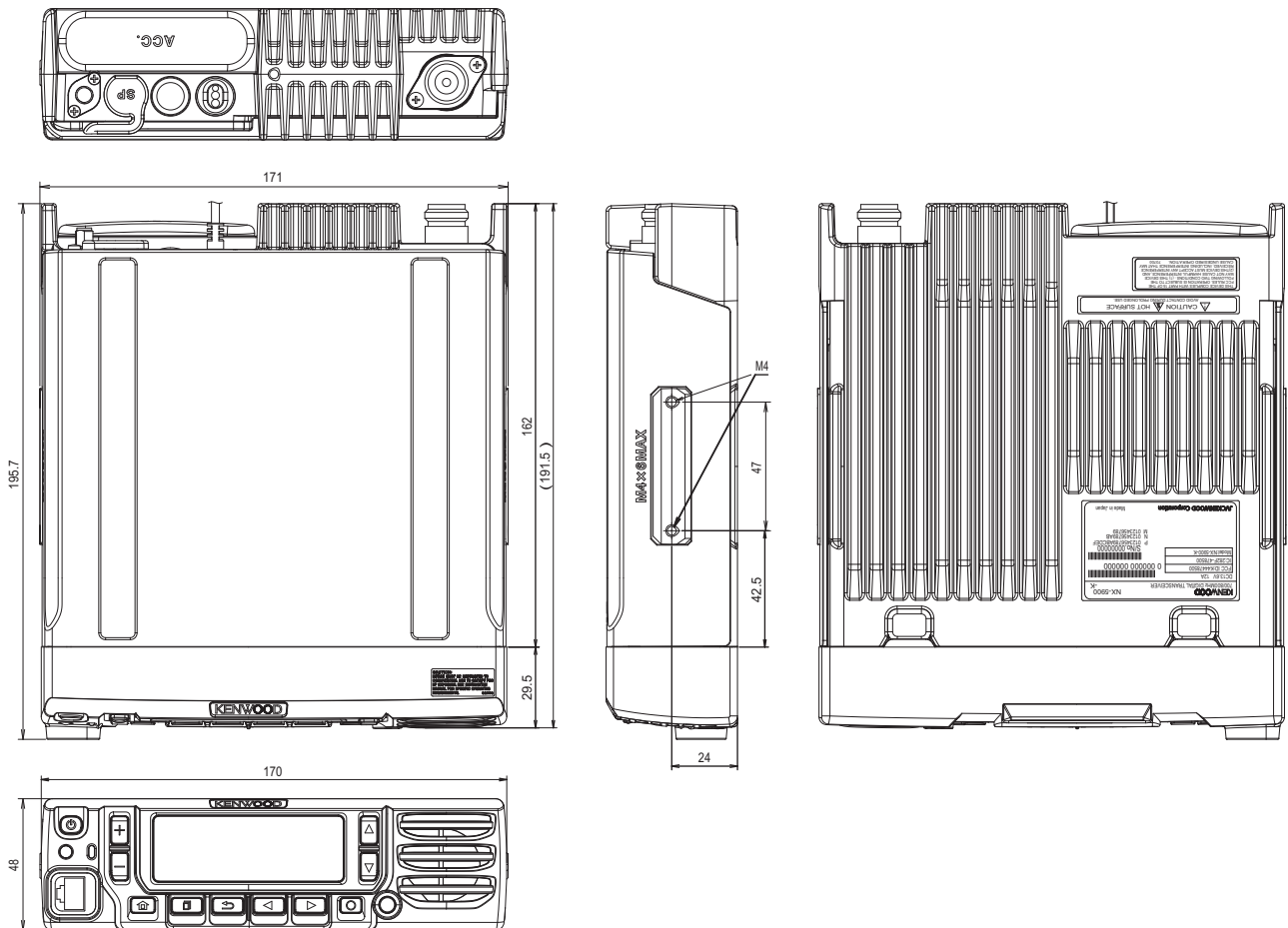

NX-5900(B) External View

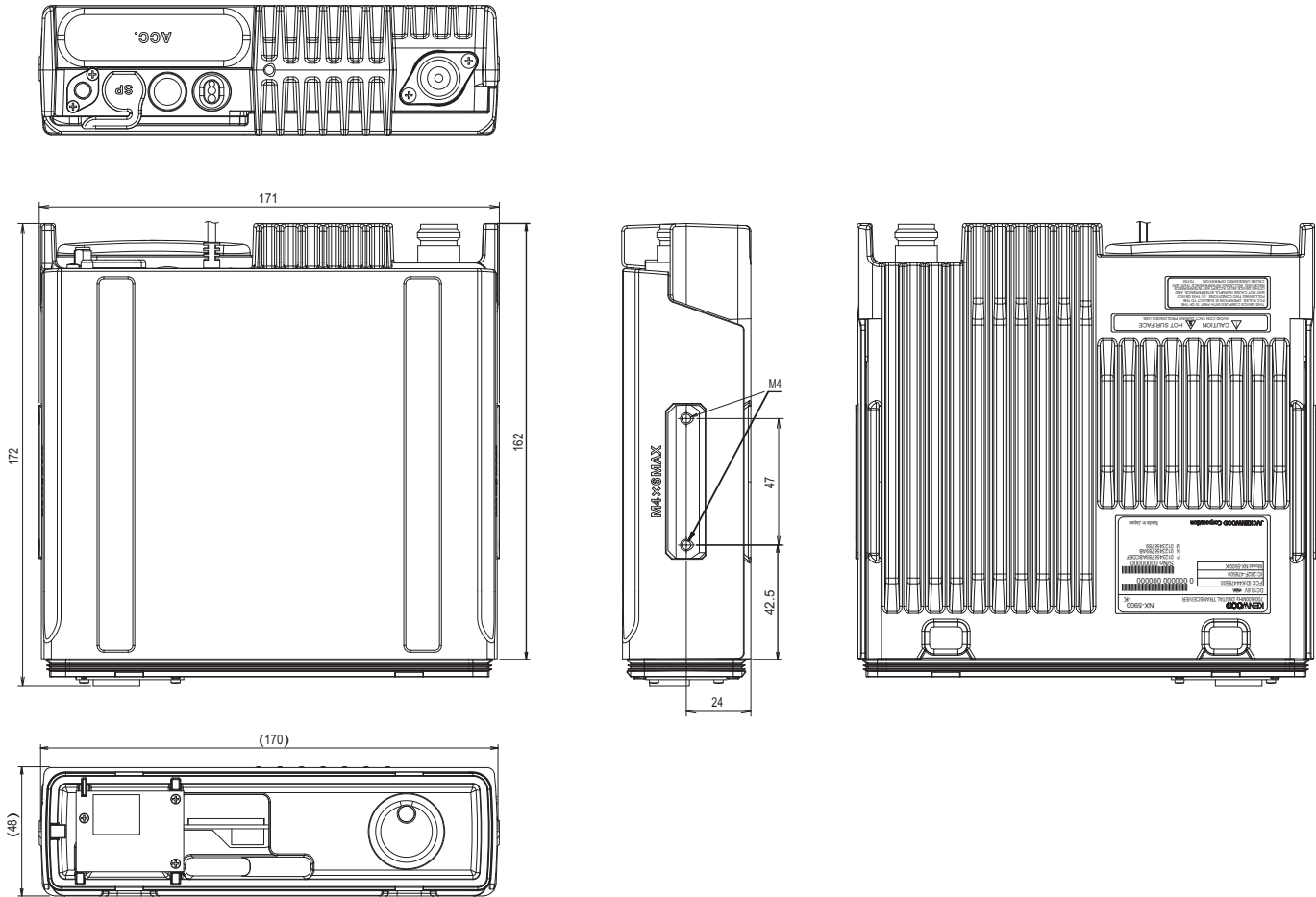

ATTENTION:

When installing the option, please take measures to prevent static electricity.

2.3.1 Ignition Sense Cable (KCT-46: Option)

The KCT-46 is an optional cable for enabling the ignition function. The ignition function lets you turn the power to the transceiver on and off with the car ignition key.

2.3.1.1 Connecting the KCT-46 cable to the transceiver

- (1) Open the KCT-46 fuse holder and insert a mini blade fuse (3A). <1>
- (2) While holding a clear protective cover, remove the black cap at the end of the yellow cable (ignition sense cable) of the transceiver. <2>
- (3) Connect the plug of the KCT-46 to the yellow cable terminal of the transceiver. <3>
- (4) Connect the other end of the KCT-46 to the ignition line of the car. <4>

Note:

You must setup using the KPG-D1/D1N.

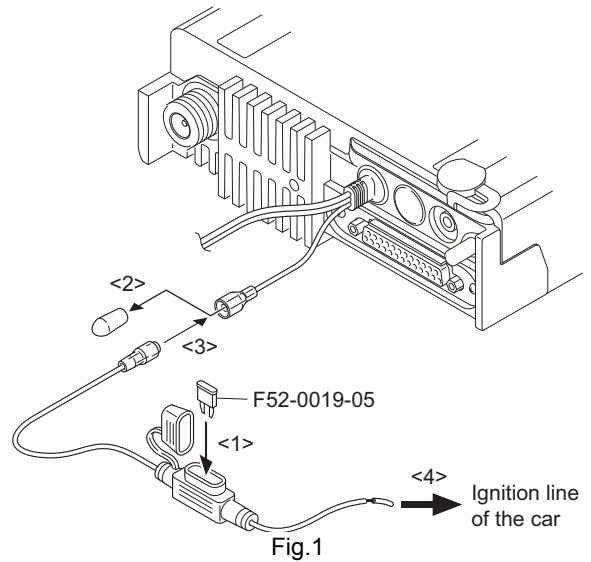

2.3.2 Horn Alert/P.A. Relay Unit (KAP-2: Option)

The Horn alert (max. 2A drive), Public address and External speaker function are enabled by installing the KAP-2 in the transceiver.

2.3.2.1 Installing the KAP-2 unit in the transceiver (The kit A is not used in the KAP-2 accessories)

- (1) Remove the cabinet, top packing and shielding plate of the transceiver.
- (2) Set the KAP-2 relay unit jumper pins according to the purpose of use.
- (3) Remove the 6-pin jumper connector inserted in the TXRX unit (A/2) connector (CN910). <1>

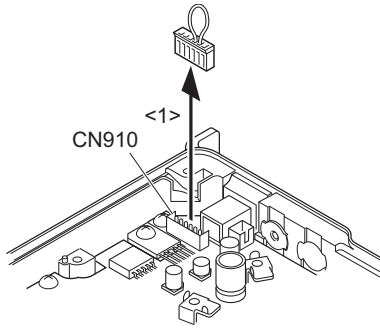

Fig.2-1

- (4) Insert one side of the lead wire with connector (E37-1114-05) into the relay unit connector (CN3) <2> and the other side into the TX-RX unit (A/2) connector (CN910) <3>

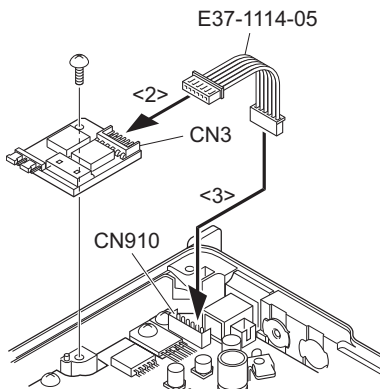

Fig.2-2

- (5) Place the relay unit at the position shown in Figure 2-2 and secure it to the chassis with a screw.
- (6) Remove the cap on the rear of the chassis by pushing it from the inside with your finger. <4>

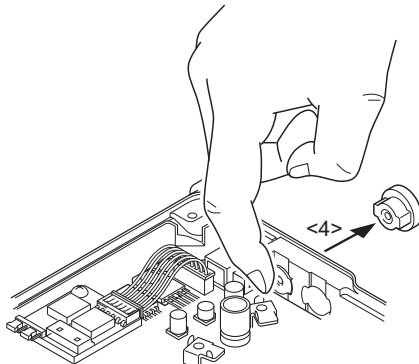

Fig.2-3

- (7) Pass the 6-pin connector of the cable (E37-1113-25) through the chassis hole <5> and insert the bush into the shassis hole.
- (8) Rotate the bush of the cable 90 degrees counterclockwise as viewed from the rear of the chassis. <6>
- (9) Insert the 6-pin connector of the cable into the connector (CN2) of the KAP-2 relay unit. <7>

Note:

You must setup using the KPG-D1/D1N.

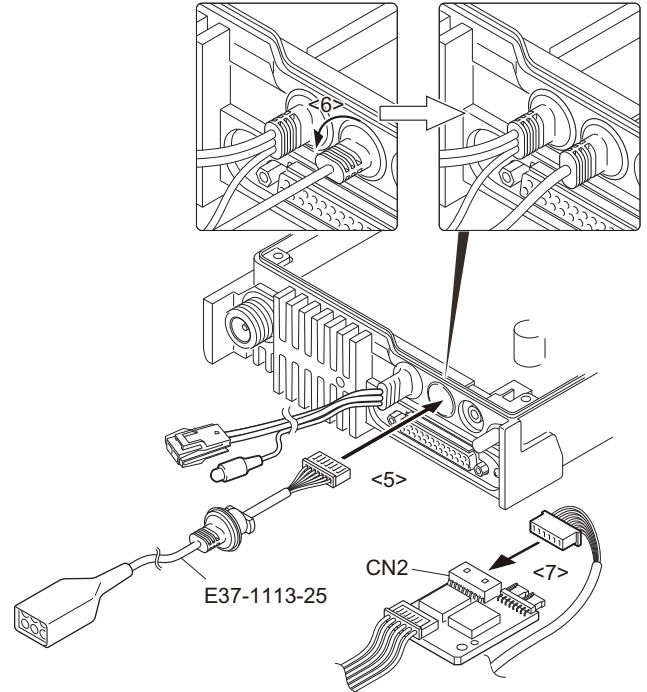
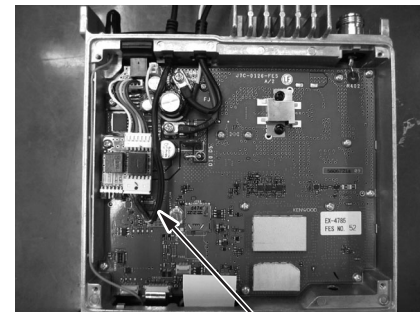

Fig.2-4

- (10) Form the KAP-2 cable as shown in the figure.



KAP-2 cable

2.3.3 External Speaker (Option)

2.3.3.1 KES-3

The KES-3 is an external speaker for the 3.5-mm-diameter speaker jack.

■Connection Procedure

Connect the KES-3 to the 3.5-mm-diameter speaker jack on the rear of the transceiver.

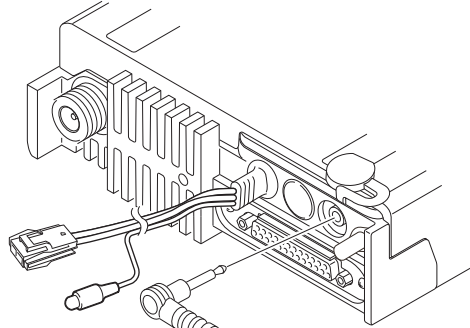

Fig.3-1

2.3.3.2 KES-5

External speaker KES-5 can be installed for KAP-2. If KES-5 is installed, it can be set by changing the CN1 short pin from pins 4 and 5 to pins 5 and 6 on the KAP-2.

KAP-2 CN1 Connect	Set Up
4-5	INT. SP or KES-3
5-6	KES-5

When you use the KES-5, plug the short pin to pins 5 and 6 on the KAP-2.

When you use the INT. SP or KES-3, plug the short pin to pins 4 and 5 on the KAP-2.

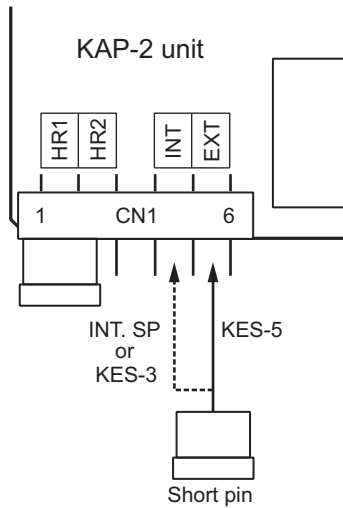

Fig.3-2

■Connection Procedure

Insert the crimp terminal into the Square plug supplied with the KAP-2.

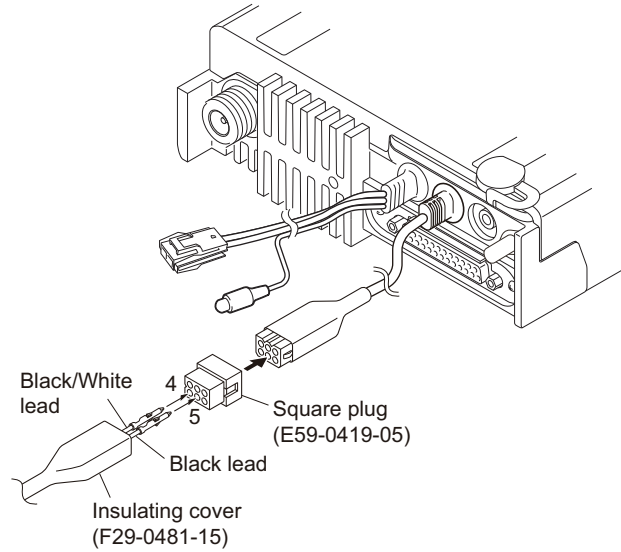
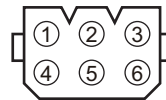

Fig.3-3

■KAP-2 Cable (E37-1113-25) 6-pin Connector



Pin No.	Color	Name
1	Red	HR2
2	Blue	GND
3	Yellow	OSP
4	Green	ESP
5	Brown	GND
6	Black	HR1

2.3.4 SECURE CRYPTOGRAPHIC MODULE (KWD-AE30/KWD-AE31:Option)

2.3.4.1 SUPPLIED ACCESSORIES

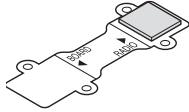

Connecting cable
(X42-3330-XX)



Cushion A*
(G13-2179-XX)

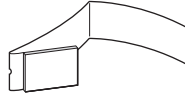

Cushion B
(G13-2178-XX)



Cushion C
(G1D-0006-XX)

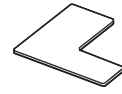

Cushion D*
(G1D-0055-XX)

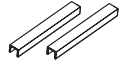

Spacer*
(F3K-0004-XX)

Note:

Supplied accessories with * mark are not used for the NX-5900.

2.3.4.2 INSTALLING THE MODULE IN THE TRANSCEIVER

- (1) Remove the cabinet, top packing and shielding plate of the transceiver.

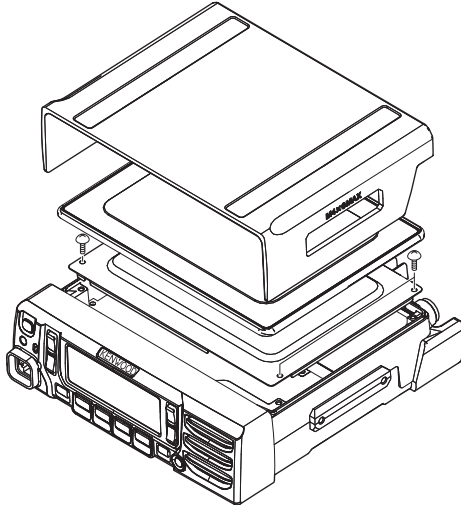

- (2) Attach the cushion B and C to the module backside.

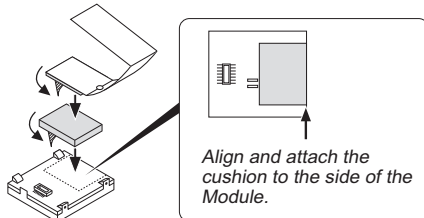

Note:

Refer to the figure for how to attach cushion B. If the release paper is reversed, it cannot be pulled out.

- (3) Fold the release paper as indicated in the figure.

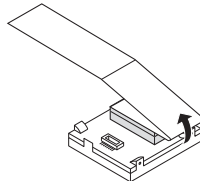

- (4) Insert the connector of the module the connector (CN731) of the TX/RX PCB into.

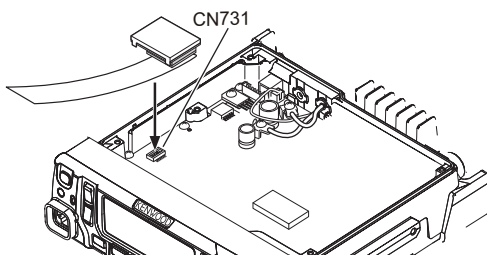

- (5) Pull and remove the release paper while pressing down on the module with your finger to hold it in place, to attach the module to the TX/RX PCB.

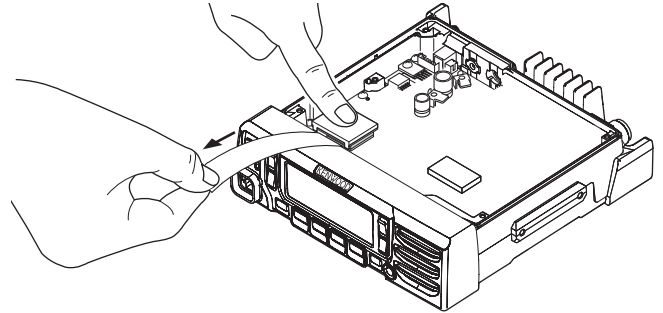

Note:

- When it is necessary to remove the module, do so by peeling the module off using your finger, while pulling it vertically. Do not use a screwdriver or other similar implement to remove the module; you may inadvertently damage the TX/RX PCB and the module.
- Cushion B cannot be reused. Attach a new cushion B when you remove the cushion from the module.

- (6) Reinstall the cabinet, top packing and shielding plate of the transceiver.

Note:

- When the KWD-AE30/ KWD-AE31 is installed, select the "Secure Cryptographic Module" checkbox in the Product Information of the Programming software [FPU (Field Programming Unit)], and then set each parameter.
- If the KWD-AE30/ KWD-AE31 connector is not properly installed, the TX/RX indicator will blink red or "No SCM" will appear on the display when the transceiver power is turned on.
- If the Encryption Key data is not written at the Keyloader, or the Encryption Key data is zeroized, "Key Fail" will appear on the display.
- If the KWD-AE30/ KWD-AE31 is installed in other transceivers, the Encryption Key data will be forced to zeroize.

2.3.5 Changing D-SUB 25-pin connector (4 pin, 5 pin) configuration

2.3.5.1 Change configuration of D-SUB 25-pin connector from AUXIO9 to CTS

■4 pin

The output (4 pin) of D-SUB 25-pin connector is configured at the AUXIO9 as the default value.

Remove the R950 chip jumpers and solder the chip jumpers to \$R952.

Ref. No.			Function
R950	\$R952	Default	AUXIO9
\$R950	R952	-	CTS (RS-232C)

2.3.5.2 Change configuration of D-SUB 25-pin connector from DI to RTS

■5 pin

The input (5 pin) of D-SUB 25-pin connector is configured at the DI as the default value.

Remove the R943 chip jumpers and solder the chip jumpers to \$R946.

Ref. No.			Function
R943	\$R946	Default	DI
\$R943	R946	-	RTS (RS-232C)

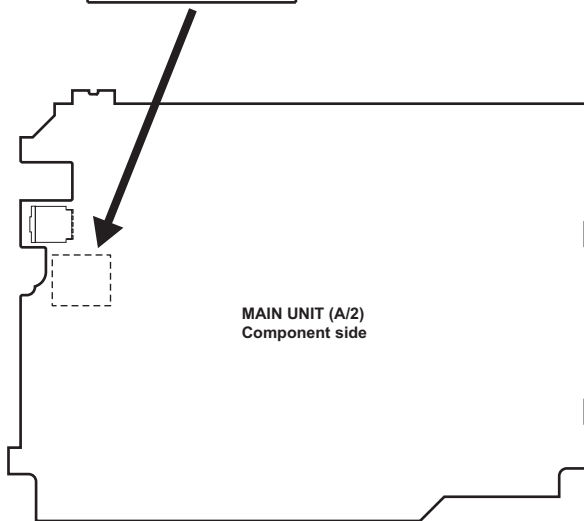
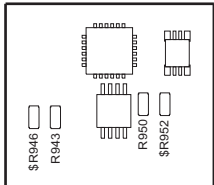

2.4 CIRCUIT DESCRIPTION

2.4.1 Overview

The NX-5900 is a 700/800MHz Analog FM & Digital Mobile transceiver designed to operate in the frequency range of 763 to 775.99375MHz, 793 to 805.99375MHz (700M) and 806 to 825MHz, 851 to 870MHz (800M). The unit consists of a receiver, a transmitter, a phase-locked loop (PLL) frequency synthesizer, a digital control unit, and a power supply circuit.

2.4.2 Frequency Configuration

The receiver is a double-conversion super-heterodyne using first intermediate frequency (IF) of 58.05MHz and second IF of 2.25MHz. Incoming signals from the antenna are mixed with the local signal from the PLL circuit to produce the first IF of 58.05MHz. This is then mixed with the 55.8MHz second local oscillator output to produce the 2.25MHz second IF. The transmit signal frequency is generated by the PLL VCO, and modulated by the signal from the DSP. It is then amplified and fed to the antenna.

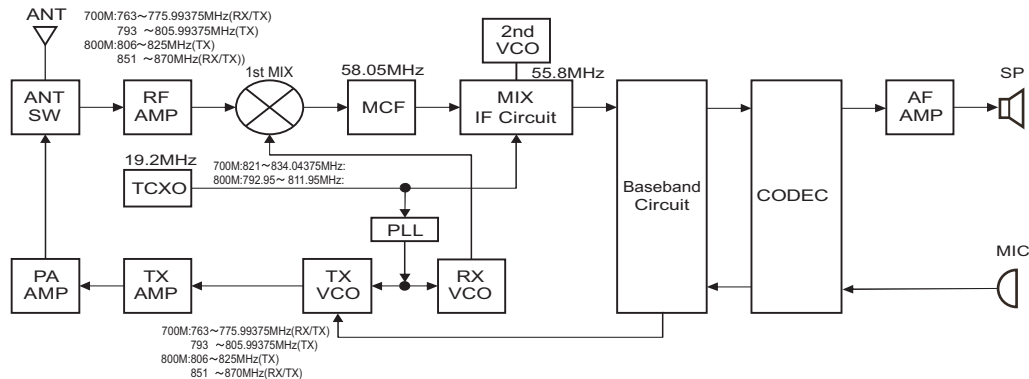

Fig.1 Frequency configuration

2.4.3 Receiver System

2.4.3.1 RF circuit

The receive signal from antenna SW (D305, D306, D308, D310, and D311) is amplified by a RF amplifier (700MHz band: Q501, 800MHz band: Q502) and passes through the band-pass filter (700MHz band: L521, L510, 800MHz band: L522, L511) to remove unwanted signals. These are controlled with the RF filter switch (IC501 and IC502). The signal is then fed to the 1st mixer (IC500).

2.4.3.2 IF circuit

The first IF signal is passed through a four-pole monolithic crystal filter (XF600) to reject adjacent channel signal. The filtered first IF signal is amplified by the first IF amplifier (Q604 and Q603) and then applied to the IF system IC (IC600). The IF system IC provides a second mixer, second PLL, AGC and A/D converter.

The second mixer mixes the first IF signal with the 55.8MHz of second local oscillator output and produces the second IF signal of 2.25MHz.

The second IF signal is then fed into an ADC, generates the I and Q data. This data is in the form of SSI (Serial Synchronous Interface), and sent to the DSP (IC706).

2.4.3.3 Audio amplifier circuit

Audio processing (high-pass filter, low-pass filter, de-emphasized and so on) at Analog FM mode and decoding at Digital mode are processed by DSP. SSI signal from DSP is converted to audio signal at IC902. The signal goes to internal speaker and connector for external speaker (J900) through the amplifier (IC903), electronic volume control (IC719) and audio amplifier (IC911).

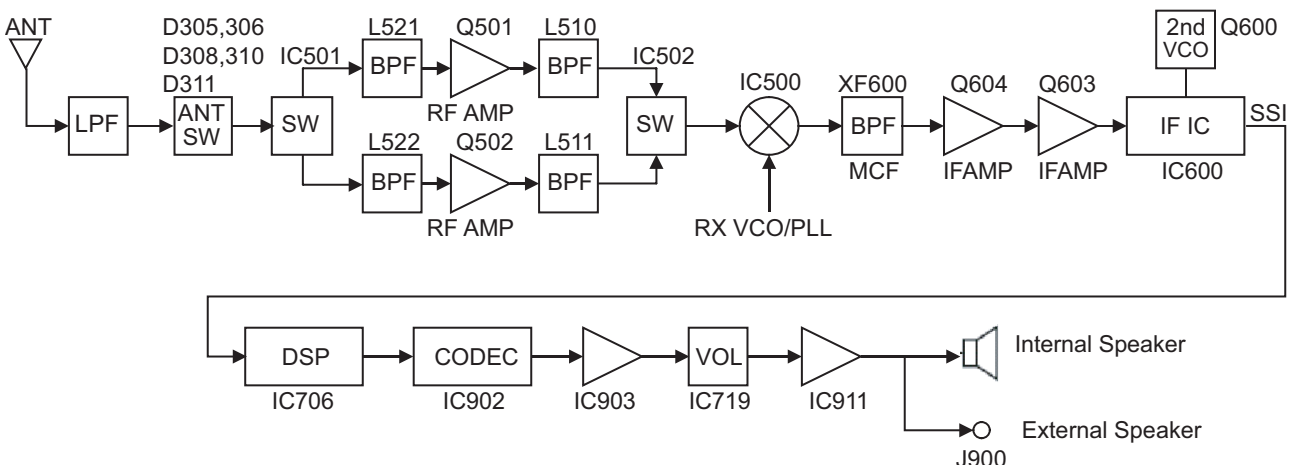

Fig.2 RF and IF circuit

2.4.4 Transmitter System

2.4.4.1 Audio Band Circuit

The signal from microphone is amplified and converted to digital signal by IC902. IC902 includes AGC function. Digital signal is transferred to IC706 thru SSI.

2.4.4.2 Base Band Circuit

The audio signal transferred from IC902 is processed at IC706. Voice signals of 300Hz or lower and frequencies of 3kHz or higher are cut off and an audio range 300Hz to 3kHz is extracted. The audio signal is then pre-emphasized in FM mode and synthesized with the signals, such as QT and DQT, as required, and is transferred to PLL Frequency Synthesizer block. The DTMF and MSK base band signals are also generated by IC706.

In Digital mode, the audio signal is converted to the 4-Level FSK base band signal and is transferred to PLL Frequency Synthesizer block.

The output level according to the transmit carrier is fine-adjusted according to each modulation method.

2.4.4.3 Drive and Final amplifier

The signal from the TX VCO is amplified by the pre-drive amplifier (IC300, Q300 and Q301). The output of the pre-drive amplifier is amplified by the drive amplifier (Q302) and the final amplifier (Q303) to 30W at 700MHz or 35W at 800MHz band (2W when the power is low). IC300 is MMIC. Q300, Q301, Q302, and Q303 are MOS FET.

The output of the final amplifier is then passed through the coupler, antenna switch (D305, D306, D308, D310, and D311), harmonic filter (LPF) and applied to the antenna terminal.

2.4.4.4 APC circuit

The automatic transmission power control (APC) circuit controls the transmitter output in adjusted value by monitoring it with a coupler. RF detection and comparison functions are included in the power-control IC (IC302).

The output of the power control IC is given as a drive source of each gate of the pre-drive amplifier (Q300 and Q301) and the drive amplifier (Q302) and completes APC feedback loop.

When a normal antenna load is connected, reflected Forward RF Power is detected by the coupler and direct in the power-control IC (IC302). Forward RF Power is converted into DC voltage in IC302 and is compared with APC1.

The output voltage goes through DC amplifier (IC303) to the pre-drive amplifier (Q300 and Q301) and the drive amplifier (Q302).

The voltage controls the gate bias1 voltage of Q300, Q301 and Q302, and keeps transmission output power stable.

SPC controls the gate bias2 voltage of Q303.

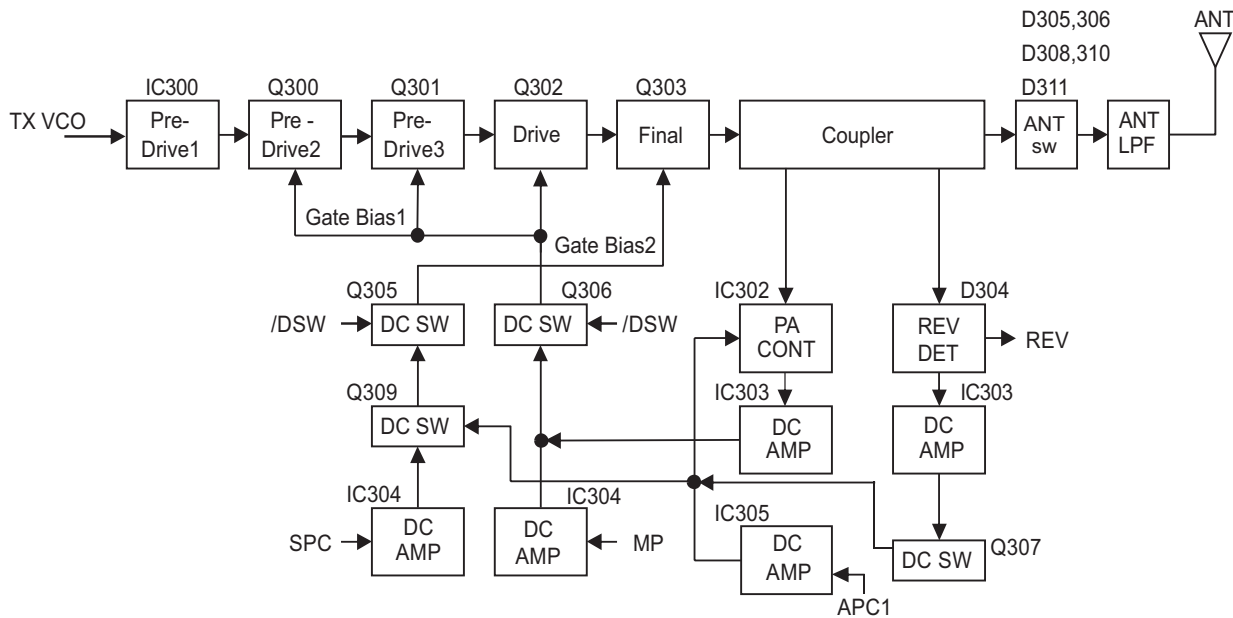

Fig.3 Drive and Final amplifier and APC circuit

2.4.5 PLL Frequency Synthesizer

2.4.5.1 TCXO (X700)

TCXO (X700) generates a reference frequency of 19.2MHz for the PLL frequency synthesizer. This reference signal is buffered by Q700 and IC703. And it is distributed to PLL (IC100), IF IC (IC600), and IC706.

The frequency adjustment is achieved by switching the ratio of dividing frequency of PLL. The resolution of adjusting frequency is approximately 8Hz.

2.4.5.2 VCO

There are TX VCO and RX VCO.

The TX VCO (Q102) generates the carrier for the transmitter. The oscillation frequency of the VCO is half of transmit frequency. VCO oscillation frequency range is 381.5 to 435MHz. The transmit frequency range is 763 to 870MHz.

The RX VCO (Q104) generates the 1st local signal for the receiver. The oscillation frequency of the VCO is half of the 1st local signal for the receiver. VCO oscillation frequency range is 396.475 to 417.025MHz. The 1st local signal frequency range is 792.95 to 834.05MHz.

The VCO oscillation frequency is determined by voltage control terminals "CV" and "ASSIST".

The voltage control terminal "CV" is controlled by PLL IC (IC100). The voltage control terminal "ASSIST" is controlled by the control voltage from D/A converter (IC715).

For the modulation input terminal, "VCO_MOD" of PLL (IC100), the output frequency changes according to the applied voltage. This is used to modulate the VCO output.

2.4.5.3 PLL IC

PLL IC (IC100) compare the difference in phases of the VCO oscillation signal and the TCXO reference frequency. And it returns the difference voltage to the VCO CV terminal and realizes the "Phase Locked Loop".

This allows the VCO oscillation frequency to accurately match (lock) the desired frequency.

When the frequency is controlled by the PLL, the frequency convergence time increases as the frequency difference increases when the set frequency is changed. To supplement this, the MPU is used before control by the PLL IC to bring the VCO oscillation frequency close to the desired frequency. As a result, the VCO CV voltage does not change and is always stable at approx. 2.5V.

The desired frequency is set for the PLL IC by the MPU (IC706) through the 3-line "SDO1", "P_SCK1", "PCS_RF" serial bus for PLL. MPU monitors through the "PLD", whether the PLL IC is locked or not. If the VCO does not lock to desired frequency (unlock), the "PLD" logic is low.

2.4.6 Control Circuit

The control circuit consists of MPU/DSP (IC706) and its peripheral circuits. IC706 mainly performs the following;

- (1) Switching between transmission and reception by PTT signal input.
- (2) Reading system, zone, frequency, and program data from the memory circuit.
- (3) Sending frequency program data to the PLL.
- (4) Controlling the audio mute circuit by decode data input.

2.4.6.1 MPU

The MPU/DSP (IC706) is 32bit RISC processor and Fixed/Floating-Point VLIW DSP, equipped with peripheral function.

This MPU operates at 288MHz (MAX) clock and 3.3V/1.8V/1.2V DC. Controls the flash memory, Mobile DDR, the receive circuit, the transmitter circuit, the control circuit, and the display circuit and transfers data to or from an external device.

2.4.6.2 Memory Circuit

Memory circuit consists of the MPU and the Mobile DDR (IC702), the flash memory (IC701). The flash memory has capacity of 512Mbit that contains the transceiver control program for the MPU and stores the data.

It also stores the data for transceiver channels and operating parameter that are written by the FPU. This program can be easily written from external devices. The Mobile DDR has capacity of 512Mbit. The MPU copies the program to the Mobile DDR from Flash memory. And MPU is used as a work area Mobile DDR.

■Flash memory

Note:

The flash memory stores the data that is written by the FPU (KPG-D1/D1N), tuning data (Deviation, Squelch, etc.) , and firmware program (User mode, Test mode, Tuning mode, etc.). This data must be rewritten when replacing the flash memory.

■Mobile DDR (static memory)

Note:

Mobile DDR is used as a work area of the MPU.

2.4.6.3 LCD

LCD interface connector (CN4) of the display unit.

The LCD is controlled using parallel interface from MPU (IC706) through the interface connectors (CN749 of the MAIN unit and CN6 of SUB unit) and flexible cable.

2.4.6.4 Key Detection Circuit

Keys are detected using I/O Expander IC (IC10) of the SUB unit. If pressed key is detected by IC10, it is informed to MPU (IC706) of the MAIN unit through serial line.

2.4.6.5 DSP

The DSP circuit consists of a MPU/DSP (IC706) and processes the baseband signal. The DSP operates at 288MHz (MAX) clock, the I/O section operates at 3.3V/1.8V and the core section operates at 1.2V.

The DSP carries out the following processes:

- 4Level FSK processing
- Analog FM pre-emphasis/de-emphasis
- Vocoder processing between audio codec and modulation/demodulation
- CAI processing, such as error correction encoding
- QT/DQT encoding/decoding
- DTMF encoding/decoding
- MSK encoding/decoding
- 2-tone encoding/decoding
- Compressor/expander processing
- Voice scrambler processing
- Transmit/receive audio filtering processing
- Microphone amplifier AGC processing
- Audio mute processing
- Modulation level processing
- Active Noise Reduction
- Voice recording/playback processing
- Voice announce processing

2.4.7 Power Supply Circuit

+B is connected to RF Power Module, 50BU regulator (Q8, Q9 and D11) through the fuse (F1), DC/DC converter IC (IC8) via fuse (F1), SB1 switch (Q5 and Q6) through the fuse (F2) and SB2 switch (Q10) through the fuse (F3).

Q8, Q9 and D11 regulates +B voltage to 5V (50BU). Then IC1 regulates 50BU to 3.1V (31BU). Then IC3 regulates 31BU to 1.2V (12BU). 50BU, 31BU and 12BU operate whenever +B is supplied.

IC8 regulates +B voltage to 5.4V (54M). 54M is controlled by BAT_CNT signal from Power management IC (IC2). When Power switch is turned on, BAR_CNT signal is controlled by /PSW signal. 54M goes to AVR ICs (A1, IC11, IC5, IC4, IC12, IC14, IC7, IC10, IC6 and IC17).

A1 (12M) is enabled while the 54M is operating. 12M provides the power to the MPU/DSP (IC706) and turns on IC11 (18M). 18M provides the power to the MPU/DSP and Mobile DDR (IC702) and turns on IC5 (33M), IC14 (33OPT). 33M provides the power to the MPU/DSP, Flash memory (IC701) and many control circuits and turns on IC4 (33A), IC10 (50A). Then 33A turns on IC9 (18M_3).

The Power management IC (IC2) watches +B voltage. If +B voltage is higher than 6.2V, IC2 outputs high voltage to the /BINT terminal. If the /BINT is high, SB1 (Q5 and Q6) and SB2 (Q10 and Q11) are turned on by SBC_2 signal from MPU. In the same way, IC12 (33C) and IC6 (50C) are turned on by SBC_2. 50C is fed to IC13 (200C). IC13 (200C) is the DC/DC boost converter. The 200C circuit then outputs approximately +20VDC.

SB1 supplies SUB unit and MAIN unit B/2 (D-sub unit) with +B voltage. SB2 supplies Audio power amplifier (IC911) and 9V AVR (IC15) with +B voltage. Then IC15 regulates +B to 9V (90C). Then IC16 regulates 90C to 5V (50CT). If the MPU controls TXC, ANT SW and ASSW signals to High, Q15, Q16 (90T), Q17, Q18 (90ANT) and Q14 are turned on and transmission circuits are enabled to transmit. If the MPU controls RXC signal to High, IC17 (50R) is turned on and reception circuits are enabled to receive.

When the Power management IC and MPU detect /PSW signal (Power switch), /IGN signal (Ignition sense) and /BINT signal, they set the SBC_2 signal to Low, and turn the transceiver power off.

When D1, Q4 detect over-voltage condition, they turn SB1 and SB2 off, and transfer that the MPU through IC2.

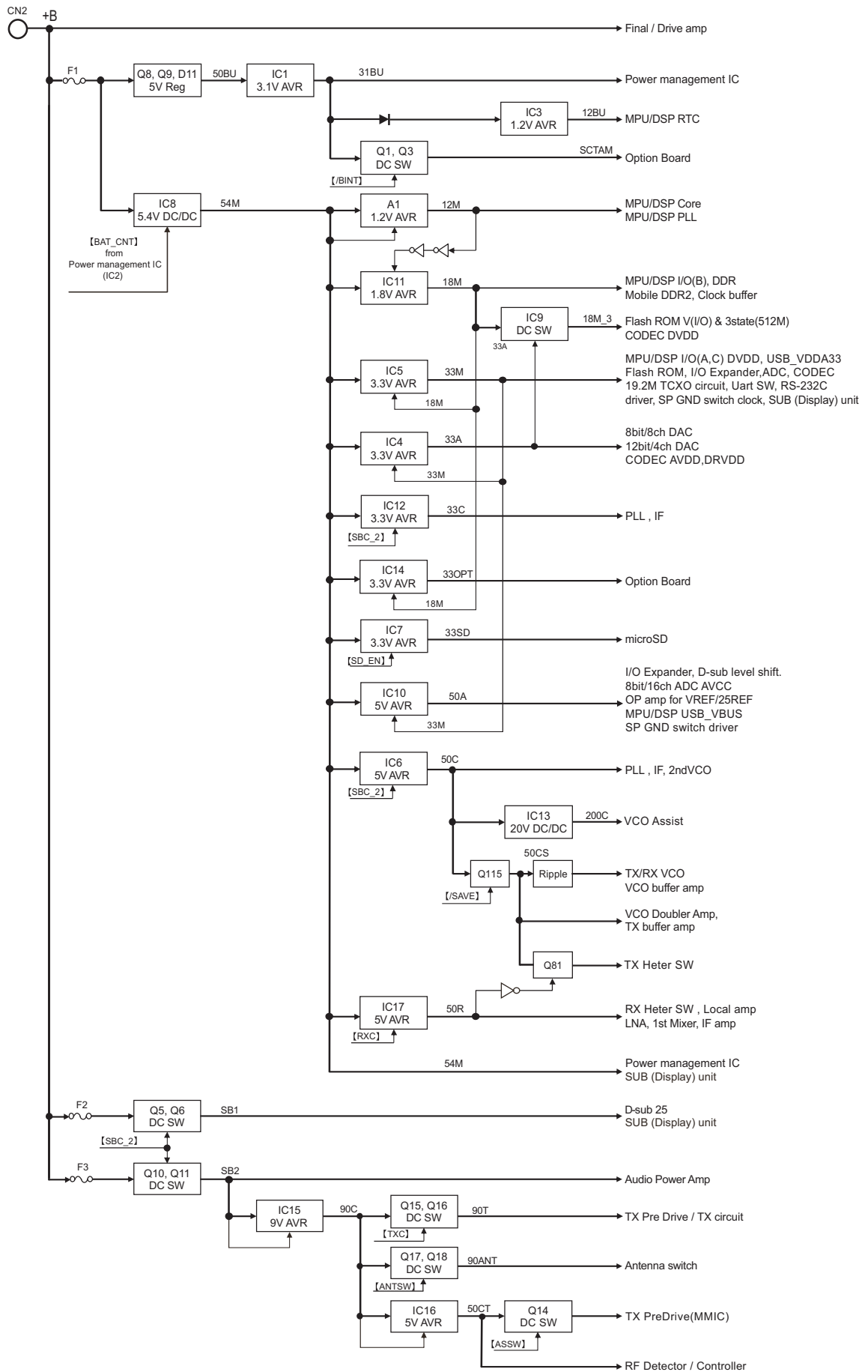

Fig.4 Power supply circuit

2.4.8 Signaling Circuit

2.4.8.1 Encode (QT/DQT/DTMF/2-tone/MSK)

Each signaling data signal of QT, DQT, DTMF, 2-tone and MSK is generated by IC706, superposed on a modulation signal and output to TX VCO and PLL IC.

2.4.8.2 Decode (QT/DQT/DTMF/2-tone/MSK)

The audio signal is removed from the FM detection signal sent to the IC706 and the resulting signal is decoded by IC706.

2.4.9 Bluetooth/GPS Circuit

The main component of the Bluetooth/GPS circuit is Bluetooth / GPS IC (IC5) on MODULE unit.

The clocks of Bluetooth/GPS IC require 19.2MHz for core and 32.768kHz slow clock (X1 and X2) for UART.

Bluetooth/GPS IC communicates to the OMAP processor (IC706) on the HCI UART. Interface of UART & Digital audio (PCM) between the OMAP processor (IC706) and the Bluetooth/GPS IC (IC5), have level conversion at the level shift IC (IC6 and IC7) on MODULE unit. The Bluetooth/GPS IC is powered by 1.8V and 3.3V which are supplied from 2 discrete external regulators (IC2 and IC3) on MODULE unit.

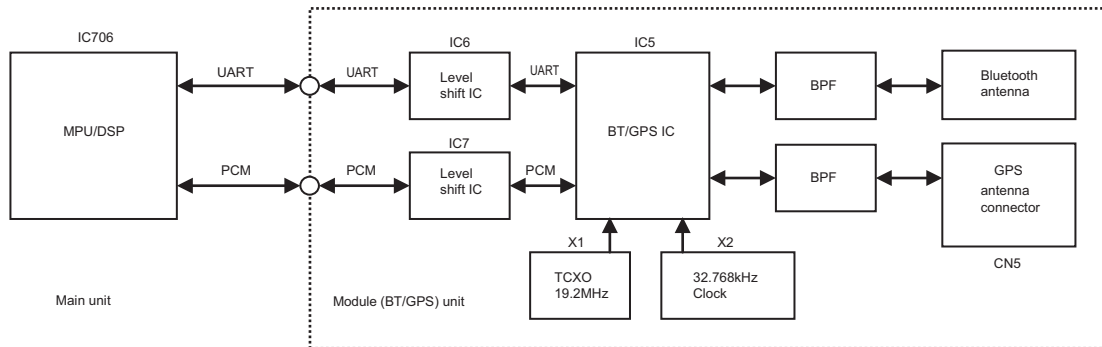

Fig.5 Bluetooth/GPS circuit

2.4.9.1 Bluetooth Circuit

The Bluetooth / GPS IC (IC5) support Bluetooth 3.0 up to HCI level.

TX/RX frequency is 2400-2483.5MHz (79ch Hopping, 2402-2480MHz, 1MHz step). Transmitting power is +2dBm at Bluetooth antenna input.

Using the printed antenna with Bluetooth, and connected to the Bluetooth / GPS IC (IC5) through the saw filter (L11).

Frequency configuration for Bluetooth is following:

There are two LO modes: 2X and Offset LO (OSLO). 2X where LO is $2 * RF_FREQ$ (e.g. when transmitting at 2441MHz it is at 4882MHz). OSLO where LO is at $(2/3) * RF_FREQ$ (e.g. when transmitting at 2441MHz it is at 1627.333MHz).

In RX the 2X is always used.

In GFSK TX if power is >10dBm then OSLO is used

In EDR2 TX if power is >-12dBm then OSLO is used

In EDR3 TX if power is >-12dBm then OSLO is used

Otherwise 2X is used for TX as well.

2.4.9.2 GPS Circuit

The GPS RF signal is received with the active antenna, and connected to the Bluetooth / GPS IC (IC5) through the terminal (CN5) and saw filter (L9).

The output is passed to pin L2 of the GPS IC. The input match for pin L2 comprises of C38, C36 and L7.

The control and data lines for the GPS IC are GPS_PA_EN, BTFM_nSHUTDOWN, GPS_TX and GPS_RX.

GPS_TX and GPS_RX are shared with Bluetooth data line.

Frequency configuration for GPS is following: Lo is GPS: 1571.324MHz

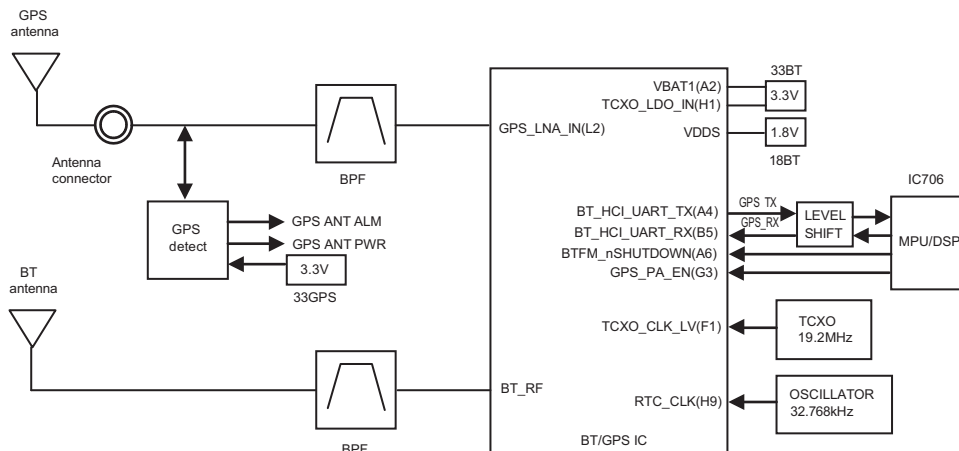

Fig.6 GPS circuit

2.5 COMPONENTS DESCRIPTION

2.5.1 Main unit (XC1-1021-80)

Ref.No	Part Name	Description
IC1	IC	Voltage regulator (31BU)
IC2	IC	Power management
IC3	IC	Voltage regulator (12BU)
IC4	IC	Voltage regulator (33A)
IC5	IC	Voltage regulator (33M)
IC6	IC	Voltage regulator (50C)
IC7	IC	Voltage regulator (33SD)
IC8	IC	DC-DC Converter (54M)
IC9	IC	Load switch (18M)
IC10	IC	Voltage regulator (50A)
IC11	IC	DC-DC Converter (18M)
IC12	IC	Voltage regulator (33C)
IC13	IC	DC-DC Converter (200C)
IC14	IC	Voltage regulator (33OPT)
IC15	IC	Voltage regulator (90C)
IC16	IC	Voltage regulator (50CT)
IC17	IC	Voltage regulator (50R)
IC18	IC	Reset
IC100	IC	PLL IC
IC101	IC	Schmitt trigger
IC102	IC	DC AMP (CV/Assist)
IC300	IC	TX pre-drive AMP
IC302	IC	TX power control
IC303~305	IC	APC
IC500	IC	RX 1st mixer
IC501, 502	IC	RX Band Switch
IC600	IC	IF IC
IC701	IC	Flash memory
IC702	IC	Mobile DDR
IC703	IC	Clock buffer
IC704, 705	IC	Logic control
IC706	IC	MPU/DSP
IC707, 708	IC	Analog switch
IC709, 710	IC	Logic control
IC711	IC	I/O expander
IC712	IC	A/D converter
IC714	IC	Analog switch
IC715	IC	D/A converter
IC719	IC	D/A converter
IC720	IC	Reset
IC900	IC	Logic control
IC901	IC	DC AMP (25REF/VREF)
IC902	IC	Codec
IC903	IC	AF AMP

Ref.No	Part Name	Description
IC904	IC	Logic control
IC905	IC	Buffer AMP (BER CK/BER DT)
IC906	IC	Level shift
IC907	IC	Analog switch
IC908	IC	Schmitt trigger
IC909	IC	RS-232C driver
IC910	IC	I/O expander
IC912	IC	Logic control
Q1	Transistor	DC switch (SCTAM1)
Q3	FET	DC switch
Q4	DIGI TRANSISTOR	DC switch
Q5	FET	DC switch (SB1)
Q6, 7	DIGI TRANSISTOR	DC switch
Q8, 9	Transistor	Voltage regulator (50BU)
Q10	FET	DC switch (SB2)
Q11	DIGI TRANSISTOR	DC switch
Q12	FET	DC switch
Q14	FET	DC switch
Q15	DIGI TRANSISTOR	DC switch
Q16	FET	DC switch (90T)
Q17	DIGI TRANSISTOR	DC switch
Q18	FET	DC switch (90ANT)
Q81	FET	T/R switch
Q102	FET	VCO oscillation
Q103	FET	DC switch
Q104	FET	VCO oscillation
Q105	Transistor	VCO Buffer amp
Q106	Transistor	VCO Doubler amp
Q107	Transistor	TX local Buffer amp
Q108	Transistor	Ripple filter
Q110	FET	DC switch
Q113	FET	T/R switch(VCO)
Q115	FET	DC switch
Q300, 301	FET	TX Pre-drive amp
Q302	FET	TX drive amp
Q303	FET	TX Final amp
Q304	FET	DC switch
Q305~307	Transistor	DC switch
Q308, 309	FET	DC switch
Q500	Transistor	RX local Buffer amp
Q501, 502	Transistor	LNA
Q503	FET	RX Band Switch

Ref.No	Part Name	Description
Q504	FET	DC switch
Q600	FET	VCO oscillation
Q601	DIGI TRANSISTOR	DC switch
Q602	Transistor	Ripple filter
Q603	Transistor	IF AMP
Q604	FET	IF AMP
Q700	Transistor	TCXO buffer
Q701	FET	DC switch
Q703, 704	FET	DC switch
Q705	DIGI TRANSISTOR	DC switch
Q900, 901	FET	Audio mute
Q902	Transistor	Audio mute
Q905, 906	FET	Audio mute
Q907, 908	FET	DC switch
D1	Zener diode	Overvoltage protection
D2	Diode	Reverse current prevention
D3	Zener diode	Overvoltage protection
D4	Diode	Reverse current prevention
D5	Surge absorber	Surge protection
D6	Diode	Backup battery charge
D7~10	Diode	Reverse current prevention
D11	Zener diode	Voltage regulator (50BU)
D12, 13	Diode	Reverse current prevention
D14	Diode	DC-DC converter (54M)
D15	Diode	DC-DC converter (200C)
D16, 17	Diode	Reverse current prevention
D100	Zener diode	Overvoltage protection
D106	VARI CAP DIODE	VCO frequency control
D107~109	VARI CAP DIODE	VCO assist tune
D110	VARI CAP DIODE	TX modulation
D111	VARI CAP DIODE	VCO frequency control
D112~114	VARI CAP DIODE	VCO assist tune
D115	DIODE	Speed up
D117	Variable capacitance diode	VCO assist tune
D300	Diode	T/R switch
D304	Diode	TX Reverse power detection
D305, 306	Diode	Antenna switch
D307	SURGE ABSORBER	Surge protection
D308	Diode	Antenna switch
D310, 311	Diode	Antenna switch
D312, 313	Zener diode	Overvoltage protection
D314	Diode	Reverse current prevention
D500	Diode	T/R switch

Ref.No	Part Name	Description
D505, 506	Diode	Overvoltage protection
D600, 601	VARI CAP DIODE	VCO frequency control
D602	Diode array	Overvoltage protection
D700, 701	Diode	Reverse current prevention
D702~706	Varistor	Line protection
D708	Zener diode	Overvoltage protection
D710, 711	Diode	Reverse current prevention
D801	Diode	Reverse current prevention
D900	Diode array	External speaker detection
D903	Zener diode	Overvoltage protection
D904	Diode array	Line protection
D905	Diode	Line protection
D906	Zener diode	Overvoltage protection
D907	Diode	Reverse current prevention
D908	Diode array	Line protection
D909	Diode array	External speaker detection
D910~915	Diode array	Line protection
D916	Diode	Reverse current prevention
D917	Zener diode	Overvoltage protection
D918~920	Diode array	Line protection
D921	Diode	Reverse current prevention
D922	Zener diode	Overvoltage protection
D923	Diode array	Line protection
D924	Diode	Reverse current prevention

2.5.2 Module (BT/GPS) unit (XC2-0031-80)

Ref.No	Part Name	Description
IC1	IC	Level converter
IC2	IC	Voltage regulator (18BT)
IC3	IC	Voltage regulator (33BT)
IC4	IC	Voltage regulator (33GPS)
IC5	IC	GPS/Bluetooth
IC6, 7	IC	Level converter
Q1	FET	DC switch
D17, 18	Diode	Overvoltage protection

2.5.3 SUB (Display) unit (XC3-0020-20) (Only NX-5900)

Ref.No	Part Name	Description
IC1	IC	Voltage regulator (50M)
IC2	IC	Voltage regulator (30LCD)
IC3	IC	Logic control
IC4	IC	Analog switch
IC6	IC	Illuminance sensor
IC8	IC	LED driver
IC9	IC	Logic control
IC10	IC	I/O expander
IC12	IC	Logic control

Ref.No	Part Name	Description
Q2	FET	DC switch
Q3, 4	DIGI TRANSISTOR	DC switch
Q6	DIGI TRANSISTOR	DC switch
D1, 2	Zener diode	Overvoltage protection
D4~7	LED	LED
D9~12	LED	LED
D14~16	LED	LED
D20	Zener diode	Overvoltage protection
D21	LED	LED
D22	Diode	Overvoltage protection
D23, 24	Zener diode	Overvoltage protection
D25	Varistor	Surge protector
D26~32	Zener diode	Overvoltage protection

2.6 TERMINAL FUNCTION

2.6.1 Main unit (XC1-1021-80)

Pin No.	Name	I/O	Function
CN4 (Ignition)			
1	IGN	I	Ignition sense input
2	GND	-	Ground
CN731 (for production)			
1~20	-	-	-
CN735 (to Module (BT/GPS) unit CN1)			
1	GPS_PWR	I	Antenna power supply detection
2	GPS_ALM	I	Antenna open/short detection
3	GND	-	Ground
4	GND	-	Ground
5	GPS_ANT_SW	O	Enable signal for 33GPS
6	GPS_PA_EN	O	GPS receiver part switching signal output
7	BT_SHUTDOWN	O	Shutdown signal output
8	WCLK	O	Audio serial data bus word clock output
9	BCLK	O	Audio serial data bus bit clock output
10	BT_AUD_DI	I	Audio signal input
11	BT_AUD_DO	O	Audio signal output
12	RTS2	O	Serial data output
13	CTS2	I	Serial data input
14	G_RXD2	I	Serial data input
15	G_TXD2	O	Serial data output
16	BT_SW	O	Enable signal for 33BT and 18BT
17	GND	-	Ground
18	GND	-	Ground
19	54M	O	5.4V output

Pin No.	Name	I/O	Function
20	54M	O	5.4V output
CN749 (to Sub (Display) unit CN6)			
1	NC (IGN)	-	No connection (Ignition sense input)
2	NC	-	No connection
3	GND	-	Ground
4	54M	O	5.4V output
5	GND	-	Ground
6	GND	-	Ground
7	18M	O	1.8V output
8	D[15]	I/O	LCD driver data output
9	D[14]	I/O	LCD driver data output
10	D[13]	I/O	LCD driver data output
11	D[12]	I/O	LCD driver data output
12	D[11]	I/O	LCD driver data output
13	D[10]	I/O	LCD driver data output
14	D[9]	I/O	LCD driver data output
15	D[8]	I/O	LCD driver data output
16	D[7]	I/O	LCD driver data output
17	D[6]	I/O	LCD driver data output
18	D[5]	I/O	LCD driver data output
19	D[4]	I/O	LCD driver data output
20	D[3]	I/O	LCD driver data output
21	D[2]	I/O	LCD driver data output
22	D[1]	I/O	LCD driver data output
23	D[0]	I/O	LCD driver data output
24	/CS_LCD	O	LCD driver chip-select signal
25	DC	O	LCD driver data/command switch signal
26	/WR_LCD	O	LCD driver WR signal
27	/RD_LCD	O	LCD driver RD signal
28	PRST	O	LCD driver reset signal
29	/KEYINT	I	Key state change signal
30	I2CCK	O	I2C serial clock
31	I2CDT	I/O	I2C serial data
32	GND	-	Ground
33	USB_D-	I/O	USB0 PHY data minus
34	USB_D+	I/O	USB0 PHY data plus
35	GND	-	Ground
36	33M	O	3.3V output
37	DM/KVL	I/O	MIC data detection
38	GND	-	Ground
39	RXD	I	Serial data input
40	TXD	O	Serial data output
41	/PTT	I	PTT input
42	/PSW	I	Detection signal input of power switch

Pin No.	Name	I/O	Function
43	AFO+	O	AF signal output plus
44	AFO-	O	AF signal output minus
45	MIC	I	MIC signal input
46	ME	-	MIC ground
47	R_SET2	I	Radio setting signal 2
48	R_SET1	I	Radio setting signal 1
49	R_SET0	I	Radio setting signal 0
50	GND	-	Ground
CN900 (to Sub (Display) unit CN2)			
1	SPO	O	Speaker output
2	SPG	-	Speaker ground
3	GND	-	Ground
4	SB1	O	Switched power supply
CN906 (to Main unit B/2 CN907)			
1	NC	-	No connection
2~7	SB1	O	Switched power supply
8	AFO	O	RX filtered AF signal out
9	DI	I	Data signal input
10	50A	O	5V output
11	GND	-	Ground
12	DEO	O	RX detected signal output
13	MI2	I	External MIC signal input
14	ME	-	MIC ground
15	GND	-	Ground
16	RXD0	I	Serial data input 0
17	AUXO2	O	AUX output2
18	TXD0	O	Serial data output 0
19	AUXO1	O	AUX output1
20	AUXIO9	I/O	AUX input/output 9
21	AUXIO5	I/O	AUX input/output 5
22	AUXIO8	I/O	AUX input/output 8
23	AUXIO4	I/O	AUX input/output 4
24	TXD2	O	Serial data output 2
25	AUXIO3	I/O	AUX input/output 3
26	RXD2	I	Serial data input 2
27	AUXIO2	I/O	AUX input/output 2
28	AUXIO1	I/O	AUX input/output 1
29	AUXIO7	I/O	AUX input/output 7
30	AUXIO6	I/O	AUX input/output 6
CN907 (to Main unit A/2 CN906)			
1	AUXIO6	I/O	AUX input/output 6
2	AUXIO7	I/O	AUX input/output 7
3	AUXIO1	I/O	AUX input/output 1
4	AUXIO2	I/O	AUX input/output 2
5	RXD2	O	Serial data output 2
6	AUXIO3	I/O	AUX input/output 3

Pin No.	Name	I/O	Function
7	TXD2	I	Serial data input 2
8	AUXIO4	I/O	AUX input/output 4
9	AUXIO8	I/O	AUX input/output 8
10	AUXIO5	I/O	AUX input/output 5
11	AUXIO9	I/O	AUX input/output 9
12	AUXO1	I	AUX input1
13	TXD0	I	Serial data input 0
14	AUXO2	I	AUX input2
15	RXD0	O	Serial data output 0
16	GND	-	Ground
17	ME	-	MIC ground
18	MI2	O	External MIC signal output
19	DEO	I	RX detected signal input
20	GND	-	Ground
21	50A	I	5V input
22	DI	O	Data signal output
23	AFO	I	RX filtered AF signal in
24~29	SB1	I	Switched power supply
30	NC	-	No connection
CN910			
1	SB2	O	Switched power supply
2	SPI	O	Speaker output
3	SPO	I	Speaker input
4	PA	O	Control signal of Public address function
5	HOR	O	Control signal of Horn alert function
6	GND	-	Ground
J700 (microSD)			
1	DAT2	I/O	Data2
2	CD/DAT3	I/O	Data3
3	CMD	I/O	Command input/output
4	VDD	O	3.3V output
5	CLK	O	Clock output
6	VSS	-	Ground
7	DAT0	I/O	Data0
8	DAT1	I/O	Data1
9	CD	I	Card detect switch
10	COMMON	-	Ground
11	GND1	-	Ground
12	GND2	-	Ground

Pin No.	Name	I/O	Function
J901 (ACC. D-Sub 25-pin)			
1	NC	-	Refer to "D-sub 25-pin connector specification".
2	RXD1	I	
3	TXD1	O	
4	AUXIO9	I/O	
5	DI	I	
6	MI2	I	
7	GND	-	
8	AUXIO8	I/O	
9	TXD2	O	
10	RXD2	I	
11	GND	-	
12	AUXIO7	I/O	
13	AUXIO6	I/O	
14	SB	-	
15	AUXO2	O	
16	AUXO1	O	
17	AFO	O	
18	GND	-	
19	DEO	O	
20	AUXIO5	I/O	
21	AUXIO4	I/O	
22	AUXIO3	I/O	
23	AUXIO2	I/O	
24	AUXIO1	I/O	
25	ME	-	

2.6.2 Module (BT/GPS) unit (XC2-0031-80)

Pin No.	Name	I/O	Function
CN1(to Main unit A/2 CN735)			
1	54M	I	5.4V input
2	54M	I	5.4V input
3	GND	-	Ground
4	GND	-	Ground
5	BT_SW	I	Enable signal for 33BT and 18BT
6	G_TXD2	I	Serial data input
7	G_RXD2	O	Serial data output
8	CTS2	O	Serial data output
9	RTS2	I	Serial data input
10	BT_AUD_DO	I	Audio signal input
11	BT_AUD_DI	O	Audio signal output
12	BCLK	I	Audio serial data bus bit clock input
13	WCLK	I	Audio serial data bus word clock input
14	BT_SHUTDOWN	I	Shutdown signal input

Pin No.	Name	I/O	Function
15	GPS_PA_EN	I	GPS receiver part switching signal input
16	GPS_ANT_SW	I	Enable signal for 33GPS
17	GND	-	Ground
18	GND	-	Ground
19	GPS_ALM	O	Antenna open/short detection
20	GPS_PWR	O	Antenna power supply detection

2.6.3 Sub (Display) unit (XC3-0020-20)

Pin No.	Name	I/O	Function
CN2 (to Main unit A/2 CN900)			
1	SP+	I	Speaker output
2	SPG	-	Speaker ground
3	GND	-	Ground
4	SB	I	Switched power supply
CN4 (LCD)			
1	VSSA	-	Ground
2	VSSA	-	Ground
3	VSSA	-	Ground
4	VCC	O	3V output
5	VCC	O	3V output
6	VSSD	-	Ground
7	VSSD	-	Ground
8	VSSD	-	Ground
9	IOVCC	O	1.8V output
10	IOVCC	O	1.8V output
11	RDX	O	LCD driver RD signal
12	WRX	O	LCD driver WR signal
13	DCX	O	LCD driver data/command switch signal
14	CSX	O	LCD driver chip-select signal
15	DB1	I/O	LCD driver data output
16	DB2	I/O	LCD driver data output
17	DB3	I/O	LCD driver data output
18	DB4	I/O	LCD driver data output
19	DB5	I/O	LCD driver data output
20	DB6	I/O	LCD driver data output
21	DB7	I/O	LCD driver data output
22	DB8	I/O	LCD driver data output
23	DB10	I/O	LCD driver data output
24	DB11	I/O	LCD driver data output
25	DB12	I/O	LCD driver data output
26	DB13	I/O	LCD driver data output
27	DB14	I/O	LCD driver data output
28	DB15	I/O	LCD driver data output
29	DB16	I/O	LCD driver data output

Pin No.	Name	I/O	Function
30	DB17	I/O	LCD driver data output
31	CABC	-	No connection
32	RESX	O	LCD driver reset signal
33	IM0	O	Interface mode select
34	LEDA	O	54M output (LED light anode)
35	LED1	I	LED light cathode 1
36	LED2	I	LED light cathode 2
37	LED3	I	LED light cathode 3
38	LED4	-	No connection
CN5 (Internal speaker)			
1	SPG	-	Speaker ground
2	SP+	O	Speaker output
CN6 (to Main unit A/2 CN749)			
1	GND	-	Ground
2	R_SET0	O	Radio setting signal 0
3	R_SET1	O	Radio setting signal 1
4	R_SET2	O	Radio setting signal 2
5	ME	-	MIC ground
6	MIC	O	MIC signal output
7	AFO-	I	AF signal input minus
8	AFO+	I	AF signal input plus
9	/PSW	O	Detection signal input of power switch
10	/PTT	O	PTT output
11	TXD	I	Serial data input
12	RXD	O	Serial data output
13	GND	-	Ground
14	DM/KVL	I/O	MIC data detection
15	33M	I	3.3V input
16	GND	-	Ground
17	USB_D+	I/O	USB0 PHY data plus
18	USB_D-	I/O	USB0 PHY data minus
19	GND	-	Ground
20	I2CDT	I/O	I2C serial data
21	I2CCK	I	I2C serial clock
22	/KEYINT	O	Key state change signal
23	PRST	I	LCD driver reset signal
24	/RD_LCD	I	LCD driver Read signal
25	/WR_LCD	I	LCD driver Write signal
26	DC	I	LCD driver data/command switch signal
27	/CS_LCD	I	LCD driver chip-select signal
28	D[0]	I/O	LCD driver data input
29	D[1]	I/O	LCD driver data input
30	D[2]	I/O	LCD driver data input
31	D[3]	I/O	LCD driver data input
32	D[4]	I/O	LCD driver data input

Pin No.	Name	I/O	Function
33	D[5]	I/O	LCD driver data input
34	D[6]	I/O	LCD driver data input
35	D[7]	I/O	LCD driver data input
36	D[8]	I/O	LCD driver data input
37	D[9]	I/O	LCD driver data input
38	D[10]	I/O	LCD driver data input
39	D[11]	I/O	LCD driver data input
40	D[12]	I/O	LCD driver data input
41	D[13]	I/O	LCD driver data input
42	D[14]	I/O	LCD driver data input
43	D[15]	I/O	LCD driver data input
44	18M	I	1.8V input
45	GND	-	Ground
46	GND	-	Ground
47	54M	I	5.4V input
48	GND	-	Ground
49	NC	-	No connection
50	NC (IGN)	-	No connection (Ignition sense input)
J1 (MIC jack)			
1	BLC_4/D+2	I/O	Back light control signal / USB PHY data plus
2	SB_2	O	Switched power supply
3	GND	-	Ground
4	PTT/TXD_3	I/O	PTT input / Serial data output
5	ME_3	-	MIC ground
6	MIC_3	I	MIC signal input
7	HOOK/RXD/D-2	I/O	Hook detection / Serial data input / USB PHY data minus
8	DM/KVL_3	I/O	MIC data detection

2.6.4 D-Sub 25-pin connector specification

Pin No.	Pin Name	I/O	Signal Type	Rating and Condition				
				Parameter	Min	Typ	Max	Unit
1	NC	-	-	-				
2	RXD1	I	Digital	Input Voltage Range	-30		30	V
				Threshold Low	0.5	1.3		V
				Threshold High		1.60	2.45	V
				Baud Rate	-		300k	bps
				CL		100		pF
3	TXD1	O	Digital	Voltage Swing (3kΩ Load)	±5	±5.2		V
				Baud Rate	-		300k	bps
				CL		100		pF
4	AUXIO9	I/O	Digital	VIH	4	-	5.2	V
				VIL	-0.5	-	1	V
				VOH (Io=-1.5mA)	4	-	5.2	V
				VOL (Io=1.5mA)	-	-	1.1	V
	CTS (RS-232C)	I	Digital	Input Voltage Range	-30		30	V
				Threshold Low	0.5	1.3		V
				Threshold High		1.75	2.6	V
5	DI	I	Analog	Input Voltage range (STD Deviation)	-	0.5	-	Vp-p
				Freq Response (STD Dev.) 20~9600Hz	-3		3	dB
	RTS (RS-232C)	O	Digital	Voltage Swing (3kΩ Load)	±5	±5.2		V
6	MI2	I	Analog	Audio Level (STD Deviation)	-	5	-	mVrms
				Allowable Freq	300		3000	Hz
				Input Impedance	-	600	-	Ω
7	GND	-	GND					
8	AUXIO8	I/O	Digital	VIH	4	-	5.2	V
				VIL	-0.5	-	1	V
				VOH (Io=-1.5mA)	4	-	5.2	V
				VOL (Io=1.5mA)	-	-	1.1	V
9	TXD2	O	Digital	VOH (Io=-1.5mA)	3.7	-	5.2	V
				VOL (Io=1.5mA)	-	-	1.1	V
				CL		100		pF
10	RXD2	I	Digital	VIH	2.8	-	5.2	V
				VIL	-	-	0.65	V
				CL		100		pF
11	GND	-	GND					
12	AUXIO7	I/O	Digital	VIH	4	-	5.2	V
				VIL	-0.5	-	1	V
				VOH (Io=-1.5mA)	3.7	-	5.2	V
				VOL (Io=1.5mA)	-	-	1.1	V
13	AUXIO6	I/O	Digital	VIH	4	-	5.2	V
				VIL	-0.5	-	1	V
				VOH (Io=-1.5mA)	3.7	-	5.2	V
				VOL (Io=1.5mA)	-	-	1.1	V

Pin No.	Pin Name	I/O	Signal Type	Rating and Condition				
				Parameter	Min	Typ	Max	Unit
14	SB	-	Power	Voltage	This parameter depends on Battery Voltage			
				Supply Current	-	-	2	A
15	AUXO2	O	Digital	The type of this port is open collector.				
				VOL			0.4	V
				IOL			-500	mA
16	AUXO1	O	Digital	The type of this port is open collector.				
				VOL			0.4	V
				IOL			-500	mA
17	AFO	O	Analog	Output Level		0.7		Vp-p
				Coupling Capacitor		10		uF
				allowable Load	100	-	-	kΩ
				allowable freq	300		3000	Hz
18	GND	-	GND					
19	DEO	O	Analog	Output Level	-	0.28	-	Vp-p
				Coupling Capacitor	-	10	-	uF
				allowable Load	47	-	-	kΩ
				Frequ. Response (STD Dev) Wide 20~4800Hz	-6		1	dB
				Wide 4800~7200Hz	-24		1	dB
				Narrow 20~4800Hz	-15		1	dB
20	AUXIO5	I/O	Digital	VIH	4	-	5.2	V
				VIL	-0.5	-	1	V
				VOH (Io=-1.5mA)	4	-	5.2	V
				VOL (Io=1.5mA)	-	-	1.1	V
21	AUXIO4	I/O	Digital	VIH	4	-	5.2	V
				VIL	-0.5	-	1	V
				VOH (Io=-1.5mA)	4	-	5.2	V
				VOL (Io=1.5mA)	-	-	1.1	V
22	AUXIO3	I/O	Digital	VIH	4	-	5.2	V
				VIL	-0.5	-	1	V
				VOH (Io=-1.5mA)	4	-	5.2	V
				VOL (Io=1.5mA)	-	-	1.1	V
23	AUXIO2	I/O	Digital	VIH	4	-	5.2	V
				VIL	-0.5	-	1	V
				VOH (Io=-1.5mA)	4	-	5.2	V
				VOL (Io=1.5mA)	-	-	1.1	V
24	AUXIO1	I/O	Digital	VIH	4	-	5.2	V
				VIL	-0.5	-	1	V
				VOH (Io=-1.5mA)	4	-	5.2	V
				VOL (Io=1.5mA)	-	-	1.1	V
25	ME	-	Analog	This is GND port for Microphone.				

SECTION 3 DISASSEMBLY

3.1 Precautions for Disassembly

3.1.1 Main PCB (Main unit A/2) disassembly

- (1) Remove all screws and antenna terminals on the Main PCB.
- (2) Rotate the bush of the power supply cable 90 degrees counterclockwise as viewed from the rear of the chassis <1> and remove the power supply cable from the chassis <2>.
- (3) When the speaker phone jack is pushed up, using your finger, from the rear of the chassis <3>, the Main PCB is removed from the chassis.

Note:

The Main PCB and D-sub PCB (Main unit B/2) are connected with a flat cable.

Remove them carefully.

- (4) Turn the Main PCB over and remove the flat cable from the connector (CN906). <4>
- (5) Remove the Main PCB from the chassis.

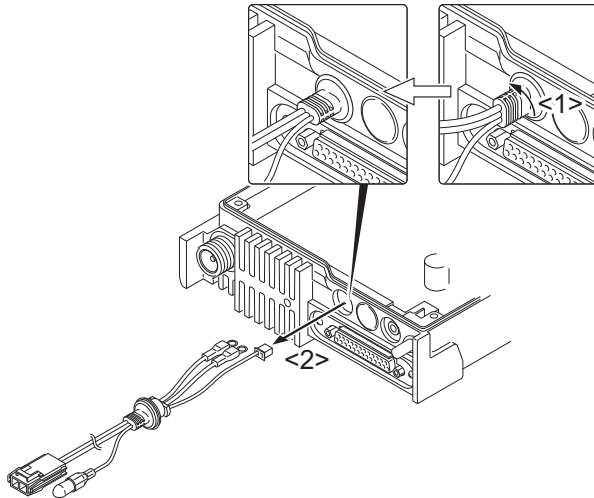

Fig.1-1

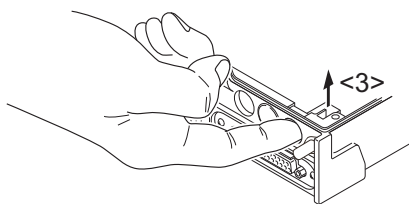

Fig.1-2

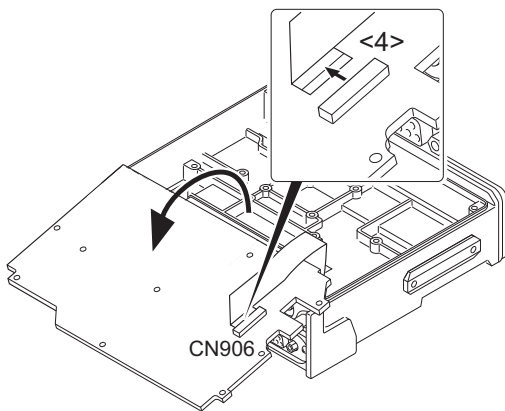

Fig.1-3

3.1.2 Removing the speaker hardware fixture (J2B-0023-00) and holder (J1K-0019-00)

- (1) Remove the speaker lead from the holder hook. <1>
- (2) Remove the speaker connector from the display unit connector (CN5). <2>
- (3) When removing the speaker hardware fixture, insert a flat-head screwdriver at the position shown in Figure 2-1 and tilt it in the direction shown by the arrow. <3>
- (4) To remove the holder, insert a flat-head screwdriver into tab of the holder and tilt it in the direction shown by the arrow. <4>

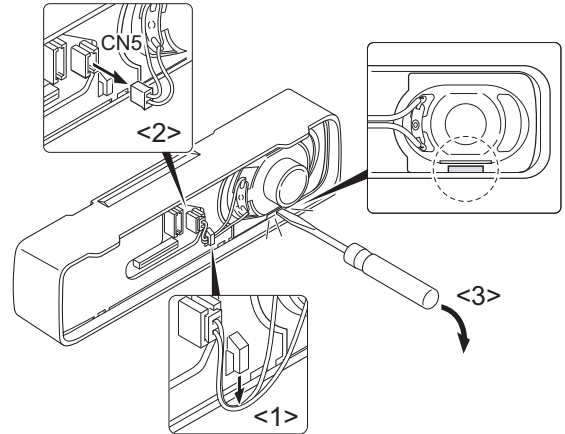

Fig.2-1

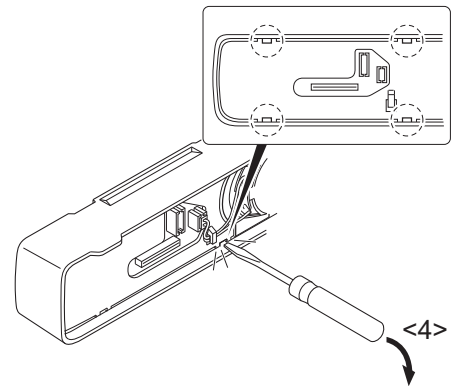

Fig.2-2

3.2 Precautions for Reassembly

3.2.1 Main PCB (Main unit A/2) reassembly

- (1) With the Main PCB turned over, insert the flat cable from the D-sub PCB (Main unit B/2) into the connector (CN906) on the Main PCB.
- (2) Place the Main PCB at its original position as shown in Figure 3.

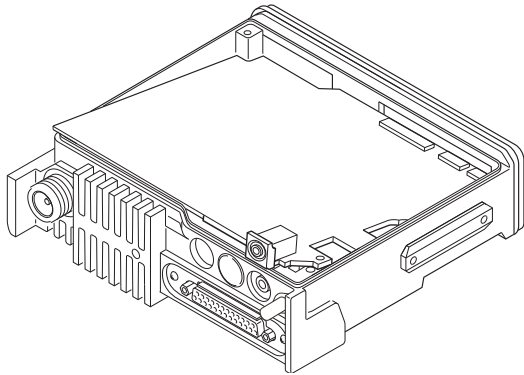

Fig.3

3.2.2 Power supply cable installation procedure

- (1) Pass the power supply cable through the chassis hole <1> as shown in Figure 4-1 and insert the bush into the chassis hole.
- (2) Rotate the bush of the power supply cable 90 degrees clockwise as viewed from the rear of the chassis. <2>
- (3) Align the ignition sense connector (yellow) of the power supply cable around the chemical capacitor (C401) and connect it to the Main unit (A/2) connector (CN4).
- (4) Align the + (positive) terminal of the power supply cable (red) as shown in Figure 4-2 and fix it to the terminal strip with a screw.
- (5) Align the - (negative) terminal of the power supply cable (black) as shown in Figure 4-2 and fix it to the terminal strip with a screw.

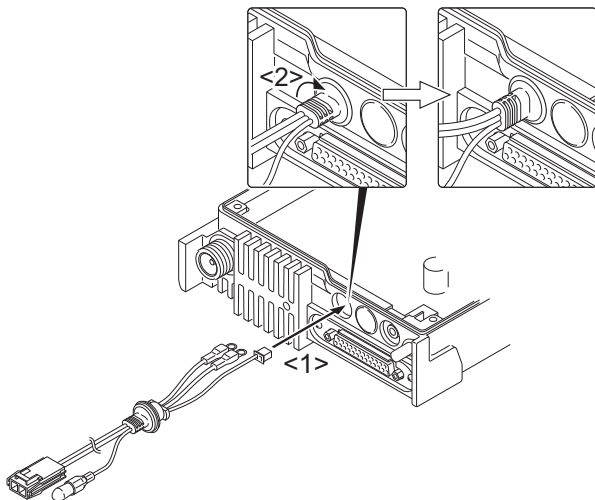

Fig.4-1

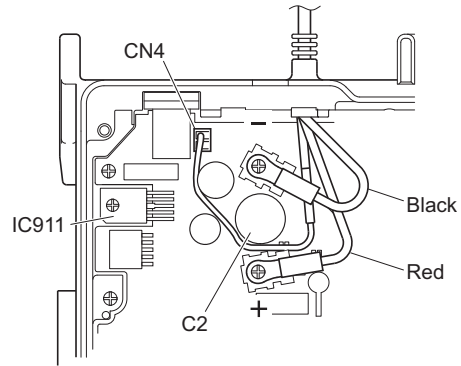
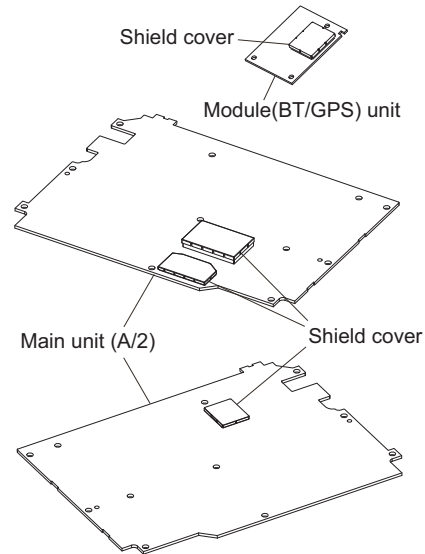

Fig.4-2

3.2.3 Remove the top cover from the shield cover

- (1) There are five shield covers on the Main unit (A/2) and Module (BT/GPS) unit, the top covers can be removed.



- (2) Use tweezers to slightly lift the edge of the top cover. <1>
- (3) As you do step 2 above, vary the position you hold the top cover as you lift it, and remove the top cover <2>.

Note:

Once the top cover is removed, it cannot be used again.

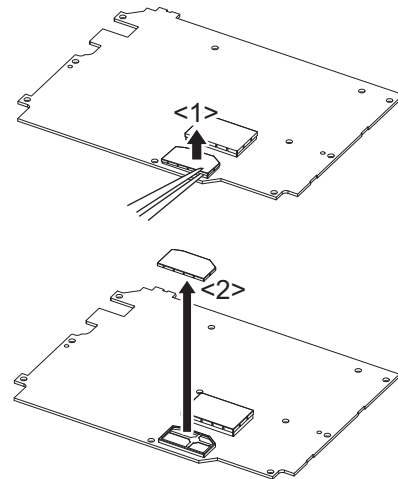

Note:

Push evenly on the top cover and be careful that you do not bend it as you install it on the shield cover.

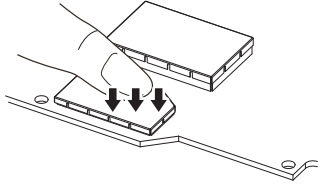

3.2.4 Top packing installation procedure

- (1) Place the top packing over the shielding plate.
- (2) Fit the convex tab of the top packing into the hollow of the chassis. <1>
- (3) Fit the chassis into the groove of the top packing. <2>
Verify that the top packing is in close contact with the chassis.

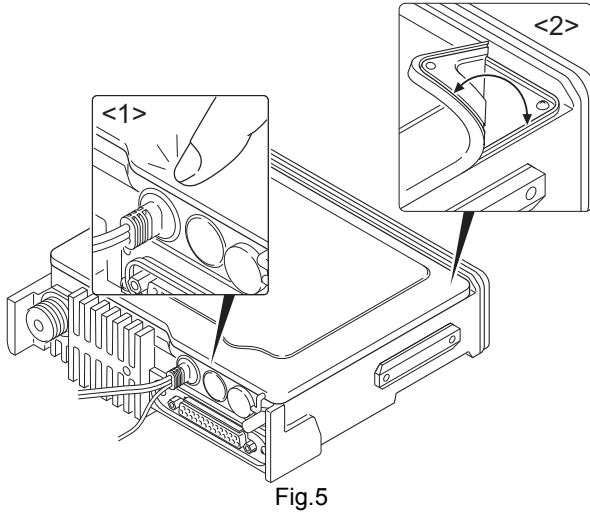

Fig.5

3.2.5 D-sub cap installation procedure

To improve water resistance, fit the D-sub cap into the D-sub terminal hardware fixture of the transceiver in the following order:

- (1) Fit the left side <1> of the D-sub cap into the hardware fixture.
- (2) Fit the right side <2> of the D-sub cap into the hardware fixture.
- (3) Fit the center <3> of the D-sub cap into the hardware fixture.

Verify that the D-sub cap is in close contact with the hardware fixture.

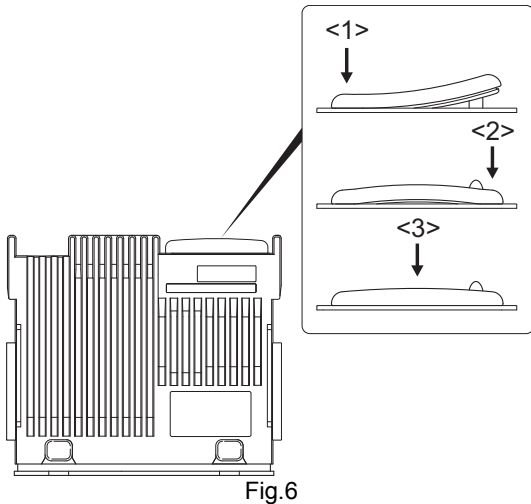

Fig.6

3.2.6 Installing the holder (J1K-0019-00) and speaker hardware fixture (J2B-0023-00)

- (1) Insert two tabs of the holder (J1K-0019-00) into the hollows in the top of the panel. <1>
- (2) Push the two tabs of the holder in on the opposite side of those in step 1 above and fit them into the hollow in the bottom of the panel. <2>

Note:

Push in the holder until it snaps in place.

- (3) Install the speaker holder onto the panel. <3>

Note:

To improve water resistance, fit the panel into the groove of the holder.

- (4) Place the speaker into the speaker holder.

Note:

The speaker must not ride on the holder rib.

- (5) Place the spacer on the speaker.
- (6) Insert the hardware fixture (J2B-0023-00) into the hollow of the panel as shown in Figure 7-3, then push two parts of the hardware fixture and fit it into the hollow of the top of the panel. (Fig. 7-3 <4>)

Note:

Push in the hardware fixture until it snaps in place.

- (7) Insert the speaker connector into the display unit connector (CN5).
- (8) Place the speaker lead on the holder hook.

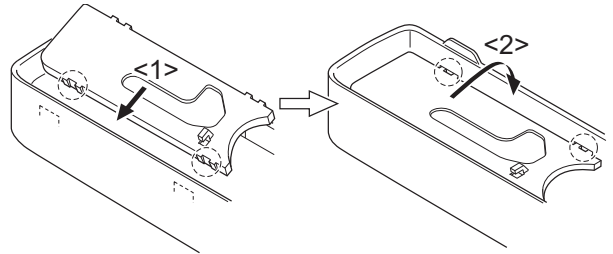

Fig.7-1

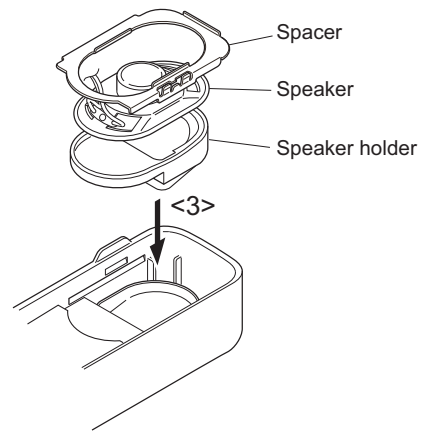

Fig.7-2

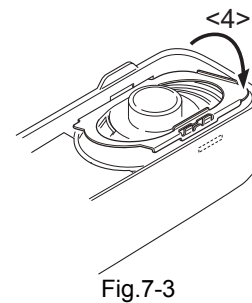
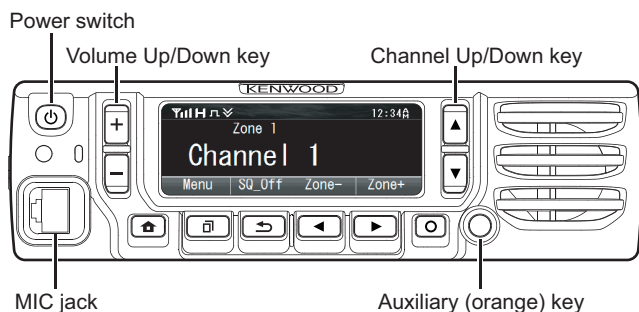

Fig.7-3

SECTION 4 ADJUSTMENT

4.1 Controls



KMC-36 (OPTION)

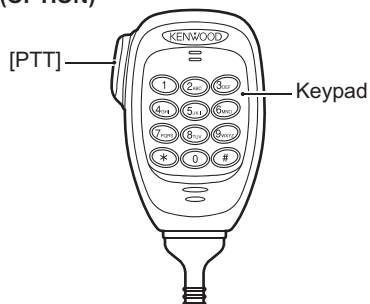

4.1.1 Preparations for checking/tuning the transceiver

Before attempting to check/tune the transceiver, connect the unit to a suitable power supply.

Whenever the transmitter is turned on, the unit must be connected to a suitable dummy load (i.e. power meter).

The speaker output connector must be terminated with an 4Ω dummy load and connected to an AC voltmeter and an audio distortion meter or a SINAD measurement meter at all times during checking/tuning.

4.2 Panel Test Mode

4.2.1 Test mode operation features

This transceiver has a test mode. To enter test mode, press and hold the [↵] key while turning the transceiver power ON. Before the transceiver enters test mode, the frequency version information appears on the LCD momentarily. Test mode can be inhibited by programming. To exit test mode, turn the transceiver power OFF. The following functions are available in test mode.

- When the panel test mode is activated, the last used channel and signaling numbers are displayed. When the panel test mode is activated for the first time, the channel and signaling numbers are 1.
- If test signaling 10 (P25 Phase1), 7 (P25 Phase2) and 7 (NXDN Mode) is selected, the result of Bit Error Rate (BER) calculation is displayed on the LCD.

4.2.2 Key operation

Key	"Func" not appears on the sub LCD display	
	Function	Display
[+]	Push: Volume up Hold: Volume up continuously	-
[-]	Push: Volume down Hold: Volume down continuously	-
[▲]	Push: Test channel up Hold: Test channel up continuously	Channel No.
[▼]	Push: Test channel down Hold: Test channel down continuously	Channel No.
[◀]	Push: Squelch level up *1 Hold: Squelch off	Squelch level Squelch off: [🔊] icon appears
[▶]	Wide 5k/Wide 4k/Narrow/ Very Narrow *2	Wide 5k: "w" Wide 4k: "s" Narrow: "n" Very Narrow: "v"
[🔍]	Shift to panel tuning mode	-
[↵]	Function on	"Func" appears on the sub LCD display
[○]	MSK 1200bps and 2400bps *1	2400bps: [📧] icon appears
[🏠]	Push: Test signaling up Hold: Test signaling up continuously	Signaling No.
[AUX (Orange)]	-	-
[PTT]	Transmit	-
[0] to [9] and [#], [*]	-	-

*1: When the mode is selected as Analog, this function is enabled.

*2: When the mode is selected as P25, bandwidth is fixed to Narrow.

Key	"Func" appears on the sub LCD display	
	Function	Display
[+]	P25 Modulation Type (C4FM/LSM) *3	LSM : [🔍] icon appears
[-]	Function off	-
[▲]	Talk Around on/off	On: [🔍] icon appears
[▼]	Mode selection Analog/P25 Phase1 /P25 Phase2/NXDN	Analog: "A" P25 Phase1: "P1" P25 Phase2: "P2" NXDN: "N"
[◀]	-	-

Key	"Func" appears on the sub LCD display	
	Function	Display
[▶]	Key/LCD check	The contents of the pressed key etc., appear.
[📶]	High power/Medium power/Low power	High: "H" Medium: "M" Low: "L"
[↶]	Function off	-
[🔊]	Compander on/off	On: 📶 icon appears
[🔊]	External Speaker on/off	On: 📶 icon appears
[AUX (Orange)]	Function off	-

Key	"Func" appears on the sub LCD display	
	Function	Display
[PTT]	Transmit	-
[0] to [9] and [#], [*]	Function off	-

*3: When the mode is selected as P25, this function is enabled.

- **LED indicator**
Red LED Lights during transmission.
Green LED Lights when there is carrier.
- **Sub LCD indicator**
"Func" Appears at function on.

• LCD display in panel test mode

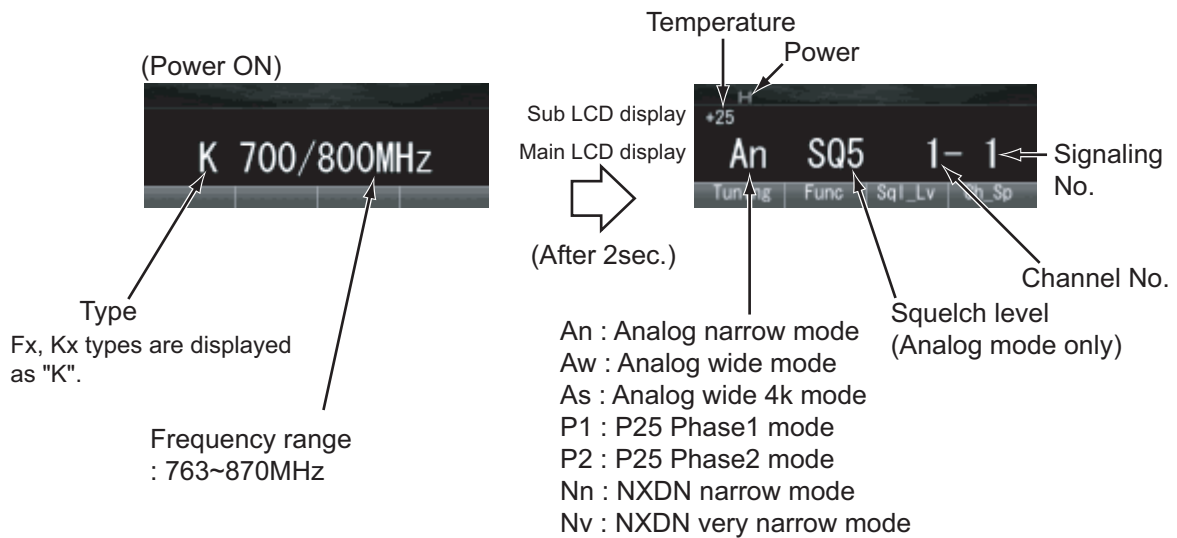

4.2.3 Frequency and Signaling

The transceiver has been adjusted for the frequencies shown in the following table. When required, readjust them following the adjustment procedure to obtain the frequencies you want in actual operation.

(1) Test frequency

CH	RX (MHz)	TX (MHz)
1	763.05000	793.05000
2	769.05000	799.05000
3	775.95000	805.95000
4	763.55000	793.55000
5	769.55000	799.55000
6	775.45000	805.45000
7	851.05000	806.05000
8	860.05000	815.05000
9	869.95000	824.95000
10	851.55000	806.55000
11	860.55000	815.55000
12	869.45000	824.45000
13~16	-	-

(2) Test signaling

■ Analog mode signaling

No.	RX	TX
1	None	None
2	None	Square Wave
3	LTR Data	LTR Data
4	QT:67.0Hz	QT:67.0Hz
5	QT:151.4Hz	QT:151.4Hz
6	QT:210.7Hz	QT:210.7Hz
7	QT:254.1Hz	QT:254.1Hz
8	DQT:D023N	DQT:D023N
9	DQT:D754I	DQT:D754I
10	DTMF Decode (CODE: 159D)	DTMF Encode (CODE: 159D)
11	None	DTMF Encode (CODE: 9)
12	2-tone Decode (A: 304.7Hz, B: 3106.0Hz)	2-tone Encode (A: 304.7Hz, B: 3106.0Hz)
13	Single Tone Decode (979.9Hz)	Single Tone Encode (979.9Hz)

No.	RX	TX
14	None	Single Tone Encode (1000Hz)
15	None	MSK PN9
16	MSK Decode	MSK Encode

■P25 Phase1 signaling

No.	RX	TX
1	NAC 293	NAC 293
2	NAC 023	NAC 023
3	NAC 5EA	NAC 5EA
4	None	PN9
5	NAC 293	Symbol Rate Pattern
6	NAC 293	1/3 Deviation Pattern
7	NAC 293	0 Continuous Pattern
8	NAC 293	Fidelity Pattern
9	None	FSW+PN9
10	None	1011Hz Tone Test Pattern
11	Tone Pattern	1011Hz Tone Test Pattern
12	Silence Pattern	Silence Pattern
13	Audio Test Pattern	NAC293 + Audio Test Pattern
14	Vocoder Loop	None

■P25 Phase2 signaling

No.	RX	TX
1	STTP-OB-1031-0	STTP-IB1031-1+Audio
2	None	PN9 Phase2
3	STTP-OB-1031-1	Symbol Rate Pattern Phase2
4	STTP-OB-1031-1	1/3 Deviation Pattern Phase2
5	STTP-OB-1031-1	0 Continuous Pattern
6	STTP-OB-1031-1	0 Burst Pattern
7	STTP-OB-1031	Symmetrical STTP-IB1031-1
8	Tone Pattern (Half rate)	STTP-IB1031-1
9	Silence Pattern (Half Rate)	STP-IB-1 + Silence Pattern (Half Rate)
10	Audio Test Pattern (Half Rate)	STTP-IB1031-1 + Audio Test Pattern (Half Rate)
11	Codec Loop	STTP-IB1031-1 + Codec Loop
12	Vocoder Loop (Half Rate)	STTP-IB1031-1 + Vocoder Loop (Half Rate)





■NXDN Mode signaling



No.	RX	TX
1	RAN1	RAN1
2	None	PN9
3	RAN1	Maximum Deviation Pattern
7	FSW + PN9	FSW + PN9
9	Tone Pattern (1031Hz)	Tone Pattern (1031Hz)

RAN: Radio Access Number
 PN9: Pseudo-Random Pattern
 No.7, 9 Item: PC test mode only

4.3 Panel Tuning Mode

4.3.1 Transceiver tuning (To enter tuning mode)



To enter tuning mode, press the [] key while the transceiver is in test mode. Use the [] key to write tuning data through tuning modes, and the []/[] key to adjust tuning requirements (1 to 4096 appears on the LCD).

Use the [] key to select the adjustment item through tuning modes. Use the [] key to adjust 4, 6 or 8 reference level adjustments, and use the [] key to switch between Wide5k/Wide4k/Narrow.

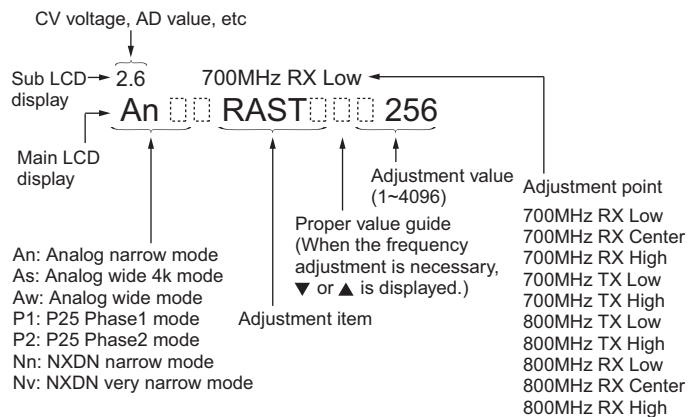
- LCD display in panel tuning mode



4.3.2 Key operation

Key	Function	
	Push	Hold (1 second)
[+]	Volume up	Continuation up
[-]	Volume down	Continuation down
[▲]	Adjustment value up	Continuation up
[▼]	Adjustment value down	Continuation down
[◀]	Auto adjustment start	-
[▶]	Wide5k/Wide4k/Narrow/P25/NXDN	-
[]	Shift to panel test mode	-
[]	To enter 4, 6 or 8 reference level adjustments	-
[○]	Writes the adjustment value	-
[]	Go to next adjustment item	Back to last adjustment item (At the time of 4, 6 or 8 point adjustment: Adjustment point change)
[AUX (Orange)]	Output tone pattern change of balance adjustment (A change is possible only during balance adjustment.)	-
[PTT] (MIC)	Transmit	
[0] to [9] and [#].[*] (MIC)	-	

4.3.3 4, 6 or 8 reference level adjustments frequency

Receive Assist

Tuning point	Display	RX (MHz)	TX (MHz)
700M RX/TA Low	700M RX/TA Low	763.100000	763.000000
700M RX/TA High	700M RX/TA High	775.900000	776.000000
800M RX/TA Low	800M RX/TA Low	851.100000	851.000000
800M RX/TA High	800M RX/TA High	869.900000	870.000000

QT Deviation, DQT Deviation, LTR Deviation, DTMF Deviation, MSK Deviation

Tuning point	Display	RX (MHz)	TX (MHz)
700M RX/TA High	700M RX/TA High	775.900000	776.000000
700M TX High	700M TX High	775.900000	805.993750
800M TX High	800M TX High	869.900000	825.000000
800M RX/TA High	800M RX/TA High	869.900000	870.000000

RSSI Reference, Open Squelch, Low RSSI, High RSSI, Tight Squelch

Tuning point	Display	RX (MHz)	TX (MHz)
700M RX/TA Low	700M RX/TA Low	763.100000	763.000000
700M RX/TA Center	700M RX/TA Center	769.100000	769.000000
700M RX/TA High	700M RX/TA High	775.900000	776.000000
800M RX/TA Low	800M RX/TA Low	851.100000	851.000000
800M RX/TA Center	800M RX/TA Center	859.900000	860.000000
800M RX/TA High	800M RX/TA High	869.900000	870.000000

Transmit Assist, Ramp Up Offset, Ramp Down Offset, High Transmit Power, Medium Transmit Power, Low Transmit Power, Balance, Maximum Deviation, P25 High Deviation, P25 H-CPM Deviation, NXDN High Deviation

Tuning point	Display	RX (MHz)	TX (MHz)
700M RX/TA Low	700M RX/TA Low	763.100000	763.000000
700M RX/TA High	700M RX/TA High	775.900000	776.000000
700M TX Low	700M TX Low	763.100000	793.000000
700M TX High	700M TX High	775.900000	805.993750
800M TX Low	800M TX Low	851.100000	806.000000
800M TX High	800M TX High	869.900000	825.000000
800M RX/TA Low	800M RX/TA Low	851.100000	851.000000
800M RX/TA High	800M RX/TA High	869.900000	870.000000

4.3.4 Adjustment item supplement

Adjustment Item	Description
Receive Assist	The lock voltage of VCO (Receive) is adjusted. This item must be adjusted before all adjustment items for receiver section are adjusted.
Transmit Assist	The lock voltage of VCO (Transmit) is adjusted. This item must be adjusted before all adjustment items for transmitter section are adjusted.
Frequency	Frequency is adjusted under receiving condition with SSG. The SSG needs 0.001ppm accuracy so please use a standard oscillator if necessary. This item can be adjusted only in PC Test Mode so that the adjustment value is not changed easily.
Ramp Offset	Adjust this item to the optimal Ramp voltage.
High Maximum Power	High Maximum Power is adjusted.
Medium Maximum Power	Medium Maximum Power is adjusted.
Low Maximum Power	Low Maximum Power is adjusted.
High Transmit Power Limit	High Transmit Power Limit is adjusted.
Medium Transmit Power Limit	Medium Transmit Power Limit is adjusted.
Low Transmit Power Limit	Low Transmit Power Limit is adjusted.
High Transmit Power	High Transmit Power is adjusted.
Medium Transmit Power	Medium Transmit Power is adjusted.
Low Transmit Power	Low Transmit Power is adjusted.
Balance	The transmit modulation frequency response is adjusted. This item is adjusted so that the deviation of 2kHz becomes the same deviation of 20Hz. This item must be adjusted before all adjustment items for deviations are adjusted.
High Deviation (P25/NXDN)	High Deviation of P25/NXDN is adjusted.
Maximum Deviation (Analog Wide 5k/ Wide 4k/Narrow)	Maximum Deviation of Analog (Analog Wide 5k/Wide 4k/Narrow) is adjusted. This item must be adjusted before all adjustment items for tone deviations are adjusted.
QT Deviation	QT tone deviation is adjusted.
DQT Deviation	DQT tone deviation is adjusted.
LTR Deviation	LTR tone deviation is adjusted.

Adjustment Item	Description
DTMF Deviation	DTMF tone deviation is adjusted.
Single Tone Deviation	The deviation of Single Tone used in "2-tone" is adjusted.
MSK Deviation	MSK tone deviation is adjusted.
CWID Deviation	CWID tone deviation is adjusted. CWID is used to inform the others who is transmitting on a 6.25-kHz spacing channel. (In FCC rule, Analog mode or CWID is required for each channel-spacing.)
RSSI Reference	The minimum RSSI level for scan stop is adjusted.
Open Squelch	The squelch level at level "5" is adjusted.
Low RSSI	RSSI display level "  " is adjusted.
High RSSI	Both "Low RSSI" and "High RSSI" must be adjusted. (The curve data of RSSI level is applied.)
Tight Squelch	The squelch level at level "9" is adjusted.

4.3.5 Adjustment item and Display

Order	Adjustment item	Main LCD display	Sub LCD display	Aw	As	An	P1	P2	Nn	Nv	Adjust item Number	
				(Analog Wide)	(Analog Wide 4k)	(Analog Narrow)	(P25 Phase1)	(P25 Phase2)	(NXDN Narrow)	(NXDN Very Narrow)		Adjustment range
1	Receive Assist	RAST	(CV voltage)	4 point ADJ								Common Section 2
				1 ~ 4096								
2	Transmit Assist	TAST	(CV voltage)	8 point ADJ								Common Section 3
				1 ~ 4096								
3	RTC Correction	RTC	-	-								Common Section 5
				-2.00~-0.01 ,0.00 ,+0.01~+2.00								
4	Ramp Up Offset	RAMPU	(ADC measurement value)	8 point ADJ								Transmitter Section 1
				1~1024								
5	Ramp Down Offset	RAMPD	(ADC measurement value)	8 point ADJ								Transmitter Section 2
				1~1024								
6	High Maximum Power	MAX_H	-	-	-	8	-	-	-	-	Transmitter Section 3	
				1~256								
7	Medium Maximum Power	MAX_M	-	-	-	8	-	-	-	-	Transmitter Section 4	
				1~256								
8	Low Maximum Power	MAX_L	-	-	-	8	-	-	-	-	Transmitter Section 5	
				1~256								
9	High Transmit Power Limit	H_LMT	-	-	-	8	-	-	-	-	Transmitter Section 6	
				1~256								
10	Medium Transmit Power Limit	M_LMT	-	-	-	8	-	-	-	-	Transmitter Section 7	
				1~256								
11	Low Transmit Power Limit	L_LMT	-	-	-	8	-	-	-	-	Transmitter Section 8	
				1~256								
12	High Transmit Power	H_PWR	-	-	-	8	-	-	-	-	Transmitter Section 9	
				1~1024								
13	Medium Transmit Power	M_PWR	-	-	-	8	-	-	-	-	Transmitter Section 10	
				1~1024								
14	Low Transmit Power	L_PWR	-	-	-	8	-	-	-	-	Transmitter Section 11	
				1~1024								
15	Balance	BAL	(Encode frequency)	-	-	8	-	-	-	-	Transmitter Section 12	
				1~1024								
16	Maximum Deviation	ADEV	-	8	8	8	-	-	-	-	Transmitter Section 13	
				1~1024								
17	P25 High Deviation	PDEV	-	-	-	-	8	-	-	-	Transmitter Section 14	
				1~1024								
18	P25 H-CPM Deviation	P2DEV	(RSSI measurement value)	-	-	-	-	8	-	-	Transmitter Section 15	
				1~1024								
19	NXDN High Deviation	NDEV	-	-	-	-	-	-	8	8	Transmitter Section 16	
				1~1024								
20	QT Deviation	QT	-	4	4	4	-	-	-	-	Transmitter Section 17	
				1~1024								
21	DQT Deviation	DQT	-	4	4	4	-	-	-	-	Transmitter Section 18	
				1~1024								

Order	Adjustment item	Main LCD display	Sub LCD display	Aw (Analog Wide)	As (Analog Wide 4k)	An (Analog Narrow)	P1 (P25 Phase1)	P2 (P25 Phase2)	Nn (NXDN Narrow)	Nv (NXDN Very Narrow)	Adjust item Number
				Adjustment range							
22	LTR Deviation	LTR	-	4	4	4	-	-	-	-	Transmitter Section 19
				1~1024							
23	DTMF Deviation	DTMF	-	4	4	4	-	-	-	-	Transmitter Section 20
				1~1024							
24	Single Tone Deviation	TONE	-	4	4	4	-	-	-	-	Transmitter Section 21
				1~1024							
25	MSK Deviation	MSK	-	4	4	4	-	-	-	-	Transmitter Section 22
				1~1024							
26	CW ID Deviation	CWID	-	-	-	4	-	-	-	-	Transmitter Section 23
				1~1024							
27	RSSI Reference	RRSSI	(RSSI measurement value)	-	-	6	-	-	-	-	Receiver Section 2
				1~256							
28	Open Squelch	SQL	(ASQDET measurement value)	6	6	6	6 *1	-	6	6	Receiver Section 3
				1~256							
29	Low RSSI	LRSSI	(RSSI measurement value)	-	-	6	-	-	-	-	Receiver Section 4
				1~256							
30	High RSSI	HRSSI	(RSSI measurement value)	-	-	6	-	-	-	-	Receiver Section 5
				1~256							
31	Tight Squelch	SQLT	(ASQDET measurement value)	6	6	6	-	-	-	-	Receiver Section 6
				1~256							

*1: When P25 Phase1 is selected, in C4FM and LSM, there is an adjustment item, respectively.

4.3.6 Panel tuning mode flow chart

Note:

* In this Panel tuning mode flow chart, the Adjustment item name is modified.

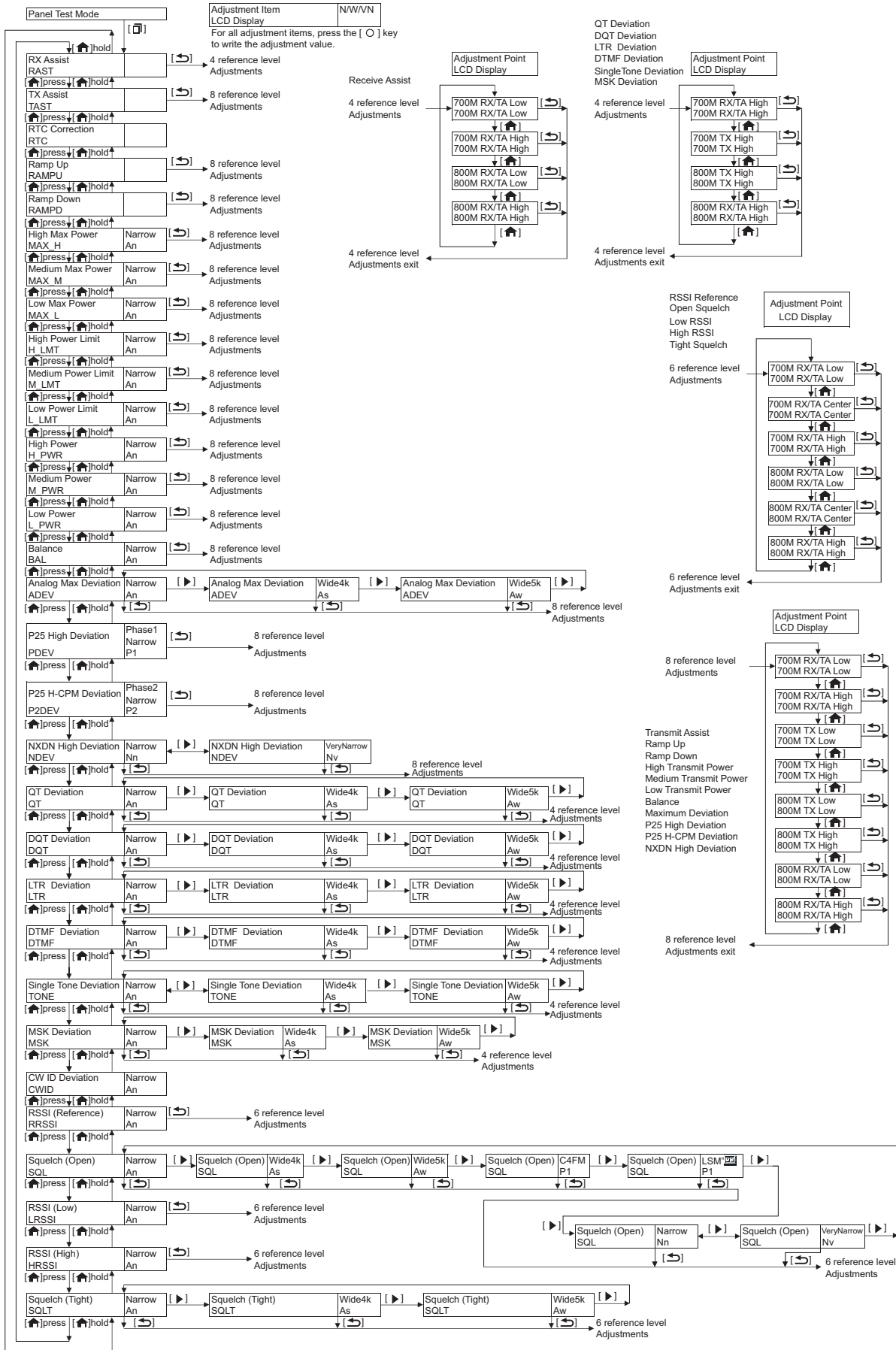

4.4 BER (Bit Error Rate) Measurement

- (1) The Panel Test Mode is used to measure the BER (Refer "4.2.1 Test mode operation features").
- (2) Select "10" (P25 Phase1), "7" (P25 Phase2) and "7" (NXDN Mode) for test signaling (Refer to "4.2.3 Frequency and Signaling" (2) Test signaling).

Note:

"7" (NXDN Mode) can be selected only by PC test mode.

- (3) Select a bandwidth (Narrow/Very Narrow) by pressing the [▶] key. When P25 Phase1 or P25 Phase2 is selected, it is not necessary to select a bandwidth.
- (4) Select a test frequency ("4.2.3 Frequency and Signaling" (2) Test signaling Test frequency).

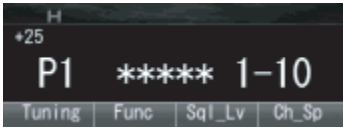

- (5) Measure the BER (Bit Error Rate) using the digital radio tester.
Enter a standard input signal into the transceiver as a standard tone test pattern for P25, FSW+PN9 for NXDN.
- (6) Adjust the input signal level to achieve the standard bit error rate (BER).

(For example, if the BER is 0.86%, the display shows "0.86".)



4.5 Adjustment points

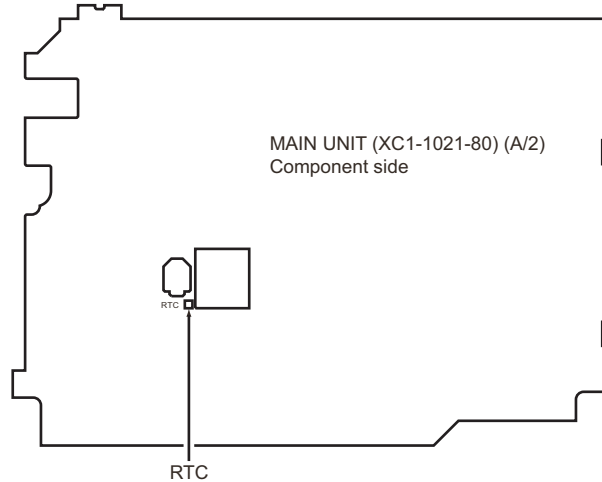

4.6 Test Equipment Required for Alignment

Test Equipment	Major Specifications	
1. Standard Signal Generator (SSG)	Frequency Range Modulation Output	100 to 900MHz Frequency modulation and external modulation -127dBm/0.1uV to greater than -20dBm/22.4mV
	When performing the Frequency adjustment, the following accuracy is necessary. • 0.001ppm Use a standard oscillator for adjustments, if necessary.	
2. Power Meter	Input Impedance Operation Frequency Measurement Capability	50Ω 100 to 900MHz Vicinity of 100W
3. Deviation Meter	Frequency Range	100 to 900MHz
4. Digital Volt Meter (DVM)	Measuring Range Input Impedance	10mV to 20V DC High input impedance for minimum circuit loading
5. Oscilloscope		DC through 30MHz
6. Frequency Counter	Frequency Range Frequency Stability	10Hz to 1000MHz 0.2ppm or less
	To measure the oscillating frequency of the internal clock 32766.00Hz~32770.00Hz for RTC Correction Resolution 0.01Hz is better for accuracy adjustment.	
7. Ammeter		20A or more
8. AF Volt Meter (AF VM)	Frequency Range Voltage Range	50Hz to 10kHz 1mV to 10V
9. Audio Generator (AG)	Frequency Range Output	50Hz to 5kHz or more 0 to 1V
10. Distortion Meter	Capability Input Level	3% or less at 1kHz 50mV to 10Vrms
11. Spectrum Analyzer	Measuring Range	DC to 1GHz or more
12. 4Ω Dummy Load		Approx. 4Ω, 10W
13. Regulated Power Supply		13.6V, approx. 20A (adjustable from 9V to 17V) Useful if ammeter equipped

*The test equipment which is not used for adjustment is contained in this table.

■ Test cable for microphone input (E30-3360-28)

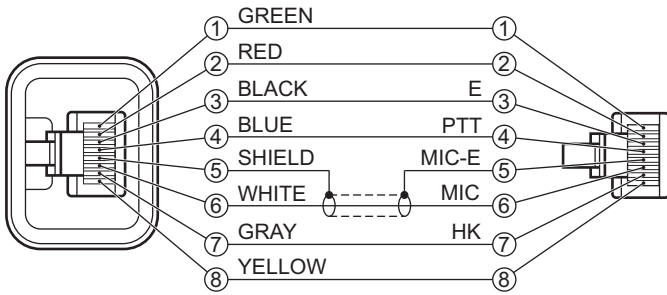

■ MIC connector (Front panel view)

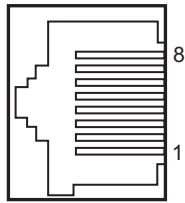

- 1 : MBL
- 2 : +B
- 3 : GND
- 4 : PTT/TXD (PC serial data from radio)
- 5 : MICE
- 6 : MIC
- 7 : HOOK/RXD (PC serial data to radio)
- 8 : DM

■ Tuning cable (E30-3383-05 or E30-7754-05)

Adapter cable (E30-3383-05 or E30-7754-05) is required for injecting an audio if PC tuning is used.
See "PC Mode" section for the connection.

Illust is E30-3383-05.

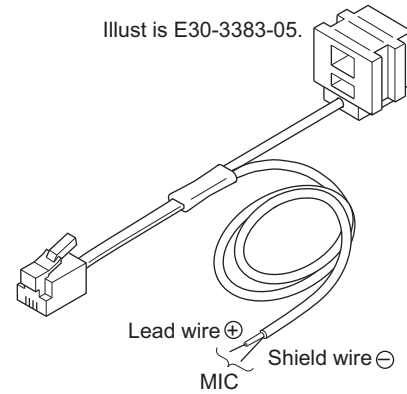

4.7 Radio check Section

Item	Condition		Measurement			Adjustment			Specifications /Remarks
	Panel test mode	PC test mode	Test-equipment	Unit	Terminal	Unit	Parts	Method	
1. Frequency check	1)CH-Sig: 1-1 PTT: ON	1)Test Channel Channel: 1 Test Signaling Mode: Analog Signaling: 1 PTT: Press [Transmit] button.	f. counter	Panel	ANT			Check an internal temperature of radio from 20°C to 33°C.	±0.25ppm ±198.3Hz@793.05MHz
2-1. High power check [700M band]	1)CH-Sig: 1-1 PTT: ON TA: OFF	1)Test Channel Channel: 1 Test Signaling Mode: Analog Signaling: 1 PTT: Press [Transmit] button.	Power meter Ammeter	Panel	ANT			Check	27.0W~30.0W 13.0A or less
	2)CH-Sig: 2-1 PTT: ON TA: OFF	2)Test Channel Channel: 2 Test Signaling Mode: Analog Signaling: 1 PTT: Press [Transmit] button.							
	3)CH-Sig: 3-1 PTT: ON TA: OFF	3)Test Channel Channel: 3 Test Signaling Mode: Analog Signaling: 1 PTT: Press [Transmit] button.							

Item	Condition		Measurement			Adjustment			Specifications /Remarks
	Panel test mode	PC test mode	Test-equipment	Unit	Terminal	Unit	Parts	Method	
2-2. High power check [700M band Talk around]	1)CH-Sig: 1-1 PTT: ON TA: ON	1)Test Channel Channel: 1 Test Signaling Mode: Analog Signaling: 1 PTT: Press [Transmit] button.	Power meter Ammeter	Panel	ANT			Check	27.0W~30.0W 13.0A or less
	2)CH-Sig: 2-1 PTT: ON TA: ON	2)Test Channel Channel: 2 Test Signaling Mode: Analog Signaling: 1 PTT: Press [Transmit] button.							
	3)CH-Sig: 3-1 PTT: ON TA: ON	3)Test Channel Channel: 3 Test Signaling Mode: Analog Signaling: 1 PTT: Press [Transmit] button.							
2-3. High power check [800M band]	1)CH-Sig: 7-1 PTT: ON TA: OFF	1)Test Channel Channel: 7 Test Signaling Mode: Analog Signaling: 1 PTT: Press [Transmit] button.	Power meter Ammeter	Panel	ANT			Check	30.0W~40.0W 13.0A or less
	2)CH-Sig: 8-1 PTT: ON TA: OFF	2)Test Channel Channel: 8 Test Signaling Mode: Analog Signaling: 1 PTT: Press [Transmit] button.							
	3)CH-Sig: 9-1 PTT: ON TA: OFF	3)Test Channel Channel: 9 Test Signaling Mode: Analog Signaling: 1 PTT: Press [Transmit] button.							
2-4. High power check [800M band Talk around]	1)CH-Sig: 7-1 PTT: ON TA: ON	1)Test Channel Channel: 7 Test Signaling Mode: Analog Signaling: 1 PTT: Press [Transmit] button.	Power meter Ammeter	Panel	ANT			Check	30.0W~40.0W 13.0A or less
	2)CH-Sig: 8-1 PTT: ON TA: ON	2)Test Channel Channel: 8 Test Signaling Mode: Analog Signaling: 1 PTT: Press [Transmit] button.							
	3)CH-Sig: 9-1 PTT: ON TA: ON	3)Test Channel Channel: 9 Test Signaling Mode: Analog Signaling: 1 PTT: Press [Transmit] button.							

Item	Condition		Measurement			Adjustment			Specifications /Remarks
	Panel test mode	PC test mode	Test-equipment	Unit	Terminal	Unit	Parts	Method	
3-1. Low power check [700M band]	1)CH-Sig: 1-1 PTT: ON TA: OFF	1)Test Channel Channel: 1 Test Signaling Mode: Analog Signaling: 1 PTT: Press [Transmit] button.	Power meter Ammeter	Panel	ANT			Check	1.5W~2.0W 5.0A or less
	2)CH-Sig: 2-1 PTT: ON TA: OFF	2)Test Channel Channel: 2 Test Signaling Mode: Analog Signaling: 1 PTT: Press [Transmit] button.							
	3)CH-Sig: 3-1 PTT: ON TA: OFF	3)Test Channel Channel: 3 Test Signaling Mode: Analog Signaling: 1 PTT: Press [Transmit] button.							
3-2. Low power check [700M band Talk around]	1)CH-Sig: 1-1 PTT: ON TA: ON	1)Test Channel Channel: 1 Test Signaling Mode: Analog Signaling: 1 PTT: Press [Transmit] button.	Power meter Ammeter	Panel	ANT			Check	1.5W~2.0W 5.0A or less
	2)CH-Sig: 2-1 PTT: ON TA: ON	2)Test Channel Channel: 2 Test Signaling Mode: Analog Signaling: 1 PTT: Press [Transmit] button.							
	3)CH-Sig: 3-1 PTT: ON TA: ON	3)Test Channel Channel: 3 Test Signaling Mode: Analog Signaling: 1 PTT: Press [Transmit] button.							
3-3. Low power check [800M band]	1)CH-Sig: 7-1 PTT: ON TA: OFF	1)Test Channel Channel: 7 Test Signaling Mode: Analog Signaling: 1 PTT: Press [Transmit] button.	Power meter Ammeter	Panel	ANT			Check	1.5W~2.0W 5.0A or less
	2)CH-Sig: 8-1 PTT: ON TA: OFF	2)Test Channel Channel: 8 Test Signaling Mode: Analog Signaling: 1 PTT: Press [Transmit] button.							
	3)CH-Sig: 9-1 PTT: ON TA: OFF	3)Test Channel Channel: 9 Test Signaling Mode: Analog Signaling: 1 PTT: Press [Transmit] button.							

Item	Condition		Measurement			Adjustment			Specifications /Remarks
	Panel test mode	PC test mode	Test-equipment	Unit	Terminal	Unit	Parts	Method	
3-4. Low power check [800M band Talk around]	1)CH-Sig: 7-1 PTT: ON TA: ON	1)Test Channel Channel: 7 Test Signaling Mode: Analog Signaling: 1 PTT: Press [Transmit] button.	Power meter Ammeter	Panel	ANT			Check	1.5W~2.0W 5.0A or less
	2)CH-Sig: 8-1 PTT: ON TA: ON	2)Test Channel Channel: 8 Test Signaling Mode: Analog Signaling: 1 PTT: Press [Transmit] button.							
	3)CH-Sig: 9-1 PTT: ON TA: ON	3)Test Channel Channel: 9 Test Signaling Mode: Analog Signaling: 1 PTT: Press [Transmit] button.							
4. MIC sensitivity check	1)CH-Sig: 1-1 AG: 1kHz PTT: ON	1)Test Channel Channel: 1 Test Signaling Mode: Analog Signaling: 1 AG: 1kHz PTT: Press [Transmit] button.	Deviation meter Oscilloscope AG AF VM	Panel	ANT Ext. SP connector			Adjust AG input to get a standard MOD.	5mV ±1mV
5-1. Sensitivity check [700M band]	1)CH-Sig: 2-1 SSG output Wide 5k: -117dBm (0.32μV) (MOD: 1kHz/±3kHz) Wide 4k: -117dBm (0.32μV) (MOD: 1kHz/ ±2.4kHz) Narrow: -117dBm (0.32μV) (MOD: 1kHz/ ±1.5kHz)	1)Test Channel Channel: 2 Test Signaling Mode: Analog Signaling: 1 SSG output Wide 5k: -117dBm (0.32μV) (MOD: 1kHz/±3kHz) Wide 4k: -117dBm (0.32μV) (MOD: 1kHz/±2.4kHz) Narrow: -117dBm (0.32μV) (MOD: 1kHz/±1.5kHz)	SSG AF VM Oscilloscope Distortion meter 4Ω Dummy load	Panel	ANT Ext. SP connector			Check	12dB SINAD or more
5-2. Sensitivity check [800M band]	1)CH-Sig: 8-1 SSG output Wide 5k: -117dBm (0.32μV) (MOD: 1kHz/±3kHz) Wide 4k: -117dBm (0.32μV) (MOD: 1kHz/ ±2.4kHz) Narrow: -117dBm (0.32μV) (MOD: 1kHz/ ±1.5kHz)	1)Test Channel Channel: 8 Test Signaling Mode: Analog Signaling: 1 SSG output Wide 5k: -117dBm (0.32μV) (MOD: 1kHz/±3kHz) Wide 4k: -117dBm (0.32μV) (MOD: 1kHz/±2.4kHz) (Narrow: -117dBm (0.32μV) (MOD: 1kHz/±1.5kHz)	SSG AF VM Oscilloscope Distortion meter 4Ω Dummy load	Panel	ANT Ext. SP connector			Check	12dB SINAD or more

4.8 Common Section

Item	Condition		Measurement			Adjustment			Specifications /Remarks
	Panel tuning mode	PC test mode	Test-equip-ment	Unit	Ter-minal	Unit	Parts	Method	
1. Setting	1) DC voltage:13.6V 2) SSG standard modulation [Wide 5k] MOD:1kHz,DEV:3kHz [Wide 4k] MOD:1kHz,DEV:2.4kHz [Narrow] MOD:1kHz,DEV:1.5kHz								
2. Receive Assist	1) Adj item: [RAST] Adjust:[****] 2) Adj item: [700M RX/TA Low]→ [700M RX/TA High]→ [800M RX/TA Low]→ [800M RX/TA High] Adjust:[****] Press [O] key to store the adjustment value.	1) Adj item: [Receive Assist] 2) Adj item: [Frequency: 700MHz Band] [RX/TA Low]→ [RX/TA High] [Frequency: 800MHz Band] [RX/TA Low]→ [RX/TA High] Press [Apply All] button to store the adjustment value.				Panel	[Panel tuning mode] [▲], [▼] [PC test mode] [←], [→]	[PC test mode] [Automatic Adjustment] 1) Press [Tune Assist Voltage] button. 2) Press [Apply All] button to store the adjustment value after the automatic adjustment has finished. [Manual Adjustment] [V] indicator on the PC window shows VCO lock voltage. Change the adjustment value to get VCO lock voltage within the limit of the specified voltage. Note: Confirm the VCO lock voltage approximately 3 seconds after the adjustment value is changed.	2.5V±0.1V [Automatic Adjustment] After the automatic adjustment is performed, verify that the VCO lock voltage is within the voltage range which is specified by the manual adjustment. [Manual Adjustment] Press [Apply All] button to store the adjustment value after all adjustment point have been adjusted. Note: The assist adjustment value must be between from 340 to 3550.
3. Transmit Assist	1) Adj item: [TAST] Adjust:[****] 2) Adj item: [700M RX/TA Low]→ [700M RX/TA High]→ [700M TX Low]→ [700M TX High]→ [800M TX Low]→ [800M TX High]→ [800M RX/TA Low]→ [800M RX/TA High] Adjust:[****] PTT: ON. Press [O] key to store the adjustment value.	1) Adj item: [Transmit Assist] 2) Adj item: [Frequency: 700MHz Band] [RX/TA Low]→ [RX/TA High]→ [TX Low]→ [TX High] [Frequency: 800MHz Band] [TX Low]→ [TX High]→ [RX/TA Low]→ [RX/TA High] PTT Press [Transmit] button. Press [Apply All] button to store the adjustment value.				Panel	[Panel tuning mode] [▲], [▼] [PC test mode] [←], [→]		

Item	Condition		Measurement			Adjustment			Specifications /Remarks
	Panel tuning mode	PC test mode	Test-equip-ment	Unit	Ter- minal	Unit	Parts	Method	
4. Frequency	*The Frequency adjustment can be performed only in PC test mode.	1) Adj item: [Frequency] SSG output: -20dBm (22.4mV) (CW (without modulation)) Caution: Perform the frequency adjustment under the following conditions. • Temperature range of +20°C to +33°C (+68.0°F to +91.4°F). (The temperature is displayed on the Frequency adjustment screen of the KPG-D1/D1N and the LCD of the transceiver.) • Use an accuracy of 0.001ppm for the SSG. (Use a standard oscillator if necessary.)	SSG	Panel	ANT	Panel	[Panel tuning mode] [▲], [▼] [PC test mode] [←], [→]	[PC test mode] Press [Start] button of "Auto Tuning". Press [Apply] button to store the adjustment value after the automatic adjustment has finished.	[PC test mode] "IF20" value = Within 0±30 digits. The value of "IF20" will become around "0" after the adjustment has finished. Remark: "Frequency" is adjusted under receiving condition with SSG.
5. RTC Corre- cition	1) Adj item: [RTC] Adjust:[****] Press [O] key to store the adjustment value.	1) Adj item: [RTC Correction] Data: [****] Press [Apply] key to store the adjustment value.	Fre- quen- cy Counte	Panel	TEST POINT (CN715)		[Panel tuning mode] [▲], [▼] [PC test mode] [←], [→]	[Panel tuning mode] Press [O] key to store the adjustment value. [PC test mode] Press [Apply] button to store the adjustment value.	Remaks: Change the adjustment value so that the frequency currently displayed on "Crystal Oscillation Frequency" on the PC window and the frequency currently displayed on the frequency counter are in agreement.

4.9 Transmitter Section

Item	Condition		Measurement			Adjustment			Specifications /Remarks
	Panel tuning mode	PC test mode	Test-equipment	Unit	Terminal	Unit	Parts	Method	
1. Ramp up Offset	<p>1) Adj item: [RAMPU] Adjust:[****]</p> <p>2) Adj item: [700M RX/TA Low]→ [700M RX/TA High]→ [700M TX Low]→ [700M TX High]→ [800M TX Low]→ [800M TX High]→ [800M RX/TA Low]→ [800M RX/TA High] PTT : ON Press [O] key to store the adjustment value.</p>	<p>1) Adj item: [Ramp Up Offset]</p> <p>2) Adj item: [Frequency: 700MHz Band] [RX/TA Low]→ [RX/TA High]→ [TX Low]→ [TX High] [Frequency: 800MHz Band] [TX Low]→ [TX High]→ [RX/TA Low]→ [RX/TA High] Press [Transmit] button. Press [Apply All] button to store the adjustment value.</p>	Power meter Ammeter	Panel	ANT	Panel	[Panel tuning mode] [▲], [▼] [PC test mode] [←], [→]	<p>[PC test mode] [Automatic Adjustment]</p> <p>1) Press [Tune Ramp Offset] button.</p> <p>2) Press [Apply All] button to store the adjustment value after the automatic adjustment has finished.</p> <p>3) Check Ramp UP Offset Monitor Value Over 45.</p> <p>[Manual Adjustment]</p> <p>1) Set the adjustment value to "1".</p> <p>2) Increase the adjustment value slowly while monitoring the offset monitor value.</p> <p>3) Set the adjustment value when the offset monitor value exceed "50".</p>	
2. Ramp down Offset	<p>1) Adj item: [RAMPD] Adjust:[****]</p> <p>2) Adj item: [700M RX/TA Low]→ [700M RX/TA High]→ [700M TX Low]→ [700M TX High]→ [800M TX Low]→ [800M TX High]→ [800M RX/TA Low]→ [800M RX/TA High] PTT : ON Press [O] key to store the adjustment value.</p>	<p>1) Adj item: [Ramp Down Offset]</p> <p>2) Adj item: [Frequency: 700MHz Band] [RX/TA Low]→ [RX/TA High]→ [TX Low]→ [TX High] [Frequency: 800MHz Band] [TX Low]→ [TX High]→ [RX/TA Low]→ [RX/TA High] Press [Transmit] button. Press [Apply All] button to store the adjustment value.</p>	Power meter Ammeter	Panel	ANT	Panel	[Panel tuning mode] [▲], [▼] [PC test mode] [←], [→]	<p>[PC test mode] [Automatic Adjustment]</p> <p>1) If "Automatic Adjustment" is completed in the item of "Ramp up Offset", this item is Completed in addition.</p> <p>2) Check "Ramp Down Offset" monitor value under "50" with PTT ON</p> <p>[Manual Adjustment]</p> <p>1) Set the following value with reference to the value that you applied in the item of "Ramp up Offset"</p> <p>2) Write calculated Value "Ramp up Offset-70".</p> <p>3) If the subtraction result is less than "1", apply "1".</p>	

Item	Condition		Measurement			Adjustment			Specifications /Remarks
	Panel tuning mode	PC test mode	Test-equipment	Unit	Terminal	Unit	Parts	Method	
3. High Maximum Power	1) Adj item: [An MAX_H] Adjust:[****] 2) Adj item: [700M RX/TA Low]→ [700M RX/TA High]→ [700M TX Low]→ [700M TX High]→ [800M TX Low]→ [800M TX High]→ [800M RX/TA Low]→ [800M RX/TA High] PTT : ON Press [O] key to store the adjustment value.	1) Adj item: [High Maximum Power] 2) Adj item: [Frequency: 700MHz Band] [RX/TA Low]→ [RX/TA High]→ [TX Low]→ [TX High] [Frequency: 800MHz Band] [TX Low]→ [TX High]→ [RX/TA Low]→ [RX/TA High] Press [Transmit] button. Press [Apply All] button to store the adjustment value.	Power meter Ammeter	Panel	ANT	Panel	[Panel tuning mode] [▲], [▼] [PC test mode] [←], [→]	45W (700M RX/TA Low, 700M RX/TA High, 700M TX Low, 700M TX High) 40W (800M RX/TA Low, 800M RX/TA High, 800MHz TX Low, 800MHz TX High)	±1.0W 15.0A or less [PC test mode] Press [Apply All] button to store the adjustment value after all adjustment point was adjusted.
4. Medium Maximum power	1) Adj item: [An MAX_M] Adjust:[****] 2) Adj item: [700M RX/TA Low]→ [700M RX/TA High]→ [700M TX Low]→ [700M TX High]→ [800M TX Low]→ [800M TX High]→ [800M RX/TA Low]→ [800M RX/TA High] PTT : ON Press [O] key to store the adjustment value.	1) Adj item: [Medium Maximum Power] 2) Adj item: [Frequency: 700MHz Band] [RX/TA Low]→ [RX/TA High]→ [TX Low]→ [TX High] [Frequency: 800MHz Band] [TX Low]→ [TX High]→ [RX/TA Low]→ [RX/TA High] Press [Transmit] button. Press [Apply All] button to store the adjustment value.	Power meter Ammeter	Panel	ANT	Panel	[Panel tuning mode] [▲], [▼] [PC test mode] [←], [→]	45W (700M RX/TA Low, 700M RX/TA High, 700M TX Low, 700M TX High) 40W (800M RX/TA Low, 800M RX/TA High, 800MHz TX Low, 800MHz TX High)	±1.0W 15.0A or less [PC test mode] Press [Apply All] button to store the adjustment value after all adjustment point was adjusted.

Item	Condition		Measurement			Adjustment			Specifications /Remarks
	Panel tuning mode	PC test mode	Test-equipment	Unit	Terminal	Unit	Parts	Method	
5. Low Maximum power	1) Adj item: [An MAX_L] Adjust:[****] 2) Adj item: [700M RX/TA Low]→ [700M RX/TA High]→ [700M TX Low]→ [700M TX High]→ [800M TX Low]→ [800M TX High]→ [800M RX/TA Low]→ [800M RX/TA High] PTT : ON Press [O] key to store the adjust- ment value.	1) Adj item: [Low Maximum Power] 2) Adj item: [Frequency: 700MHz Band] [RX/TA Low]→ [RX/TA High]→ [TX Low]→ [TX High] [Frequency: 800MHz Band] [TX Low]→ [TX High]→ [RX/TA Low]→ [RX/TA High] Press [Transmit] button. Press [Apply All] button to store the adjustment value.	Power meter Ammeter	Panel	ANT	Panel	[Panel tuning mode] [▲], [▼] [PC test mode] [←], [→]	45W (700M RX/TA Low, 700M RX/TA High, 700M TX Low, 700M TX High) 40W (800M RX/TA Low, 800M RX/TA High, 800MHz TX Low, 800MHz TX High)	±1.0W 15.0A or less [PC test mode] Press [Apply All] button to store the adjustment value after all adjustment point was adjusted.
6. High Trans- mit Power Limit	1) Adj item: [An H_LMT] Adjust:[****] 2) Adj item: [700M RX/TA Low]→ [700M RX/TA High]→ [700M TX Low]→ [700M TX High]→ [800M TX Low]→ [800M TX High]→ [800M RX/TA Low]→ [800M RX/TA High] PTT : OFF Press [O] key to store the adjust- ment value.	1) Adj item: [High Transmit Power Limit] 2) Adj item: [Frequency: 700MHz Band] [RX/TA Low]→ [RX/TA High]→ [TX Low]→ [TX High] [Frequency: 800MHz Band] [TX Low]→ [TX High]→ [RX/TA Low]→ [RX/TA High] Press [Transmit] button. Press [Apply All] button to store the adjustment value.	Power meter Ammeter	Panel	ANT	Panel	[Panel tuning mode] [▲], [▼] [PC test mode] [←], [→]	Write the value as followings. 256 (Fixed)	

Item	Condition		Measurement			Adjustment			Specifications /Remarks
	Panel tuning mode	PC test mode	Test-equipment	Unit	Terminal	Unit	Parts	Method	
7. Medium Transmit Power Limit	1) Adj item: [An M_LMT] Adjust:[****] 2) Adj item: [700M RX/TA Low]→ [700M RX/TA High]→ [700M TX Low]→ [700M TX High]→ [800M TX Low]→ [800M TX High]→ [800M RX/TA Low]→ [800M RX/TA High] PTT : OFF Press [O] key to store the adjustment value.	1) Adj item: [Medium Transmit Power Limit] 2) Adj item: [Frequency: 700MHz Band] [RX/TA Low]→ [RX/TA High]→ [TX Low]→ [TX High] [Frequency: 800MHz Band] [TX Low]→ [TX High]→ [RX/TA Low]→ [RX/TA High] Press [Transmit] button. Press [Apply All] button to store the adjustment value.	Power meter Ammeter	Panel	ANT	Panel	[Panel tuning mode] [▲], [▼] [PC test mode] [←], [→]	Write the value as followings. 256 (Fixed)	
8. Low Transmit Power Limit	1) Adj item: [An L_LMT] Adjust:[****] 2) Adj item: [700M RX/TA Low]→ [700M RX/TA High]→ [700M TX Low]→ [700M TX High]→ [800M TX Low]→ [800M TX High]→ [800M RX/TA Low]→ [800M RX/TA High] PTT : OFF Press [O] key to store the adjustment value.	1) Adj item: [Low Transmit Power Limit] 2) Adj item: [Frequency: 700MHz Band] [RX/TA Low]→ [RX/TA High]→ [TX Low]→ [TX High] [Frequency: 800MHz Band] [TX Low]→ [TX High]→ [RX/TA Low]→ [RX/TA High] Press [Transmit] button. Press [Apply All] button to store the adjustment value.	Power meter Ammeter	Panel	ANT	Panel	[Panel tuning mode] [▲], [▼] [PC test mode] [←], [→]	Write the value as followings. 256 (Fixed)	

Item	Condition		Measurement			Adjustment			Specifications /Remarks
	Panel tuning mode	PC test mode	Test-equipment	Unit	Terminal	Unit	Parts	Method	
9. High Transmit Power	1) Adj item: [An H_PWR] Adjust:[****] 2) Adj item: [700M RX/TA Low]→ [700M RX/TA High]→ [700M TX Low]→ [700M TX High]→ [800M TX Low]→ [800M TX High]→ [800M RX/TA Low]→ [800M RX/TA High] PTT : ON Press [O] key to store the adjustment value.	1) Adj item: [High Transmit Power] 2) Adj item: [Frequency: 700MHz Band [RX/TA Low]→ [RX/TA High]→ [TX Low]→ [TX High] [Frequency: 800MHz Band [TX Low]→ [TX High]→ [RX/TA Low]→ [RX/TA High] Press [Transmit] button. Press [Apply All] button to store the adjustment value.	Power meter Ammeter	Panel	ANT	Panel	[Panel tuning mode] [▲], [▼] [PC test mode] [←], [→]	[7RL]: 28.5W [7RH]: 28.5W [7TL]: 28.5W [7TH]: 28.5W [8TL]: 35.0W [8TH]: 35.0W [8RL]: 35.0W [8RH]: 35.0W	±1.0W 13.0A or less [PC test mode] Press [Apply All] button to store the adjustment value after all adjustment point was adjusted.
10. Medium Transmit Power	1) Adj item: [An M_PWR] Adjust:[****] 2) Adj item: [700M RX/TA Low]→ [700M RX/TA High]→ [700M TX Low]→ [700M TX High]→ [800M TX Low]→ [800M TX High]→ [800M RX/TA Low]→ [800M RX/TA High] PTT : ON Press [O] key to store the adjustment value.	1) Adj item: [Medium Transmit Power] 2) Adj item: [Frequency: 700MHz Band [RX/TA Low]→ [RX/TA High]→ [TX Low]→ [TX High] [Frequency: 800MHz Band [TX Low]→ [TX High]→ [RX/TA Low]→ [RX/TA High] Press [Transmit] button. Press [Apply All] button to store the adjustment value.	Power meter Ammeter	Panel	ANT	Panel	[Panel tuning mode] [▲], [▼] [PC test mode] [←], [→]	1.75W Note: Medium transmit power is the purpose of the custom power (adjustment). This power must be lower than High transmit power. In the production, this Medium transmit power is adjusted at 1.75W.	±0.2W 5.0A or less [PC test mode] Press [Apply All] button to store the adjustment value after all adjustment point was adjusted.

Item	Condition		Measurement			Adjustment			Specifications /Remarks
	Panel tuning mode	PC test mode	Test-equipment	Unit	Terminal	Unit	Parts	Method	
11. Low Transmit Power	1) Adj item: [An L_PWR] Adjust:[****] 2) Adj item: [700M RX/TA Low]→ [700M RX/TA High]→ [700M TX Low]→ [700M TX High]→ [800M TX Low]→ [800M TX High]→ [800M RX/TA Low]→ [800M RX/TA High] PTT : ON Press [O] key to store the adjustment value.	1) Adj item: [Low Transmit Power] 2) Adj item: [Frequency: 700MHz Band] [RX/TA Low]→ [RX/TA High]→ [TX Low]→ [TX High] [Frequency: 800MHz Band] [TX Low]→ [TX High]→ [RX/TA Low]→ [RX/TA High] Press [Transmit] button. Press [Apply All] button to store the adjustment value.	Power meter Ammeter	Panel	ANT	Panel	[Panel tuning mode] [▲], [▼] [PC test mode] [←], [→]	1.75W	±0.2W 5.0A or less [PC test mode] Press [Apply All] button to store the adjustment value after all adjustment point was adjusted.
12. Balance *1	1) Adj item: [An BAL] Adjust:[****] Deviation meter LPF: 3kHz HPF: OFF 2) Adj item: [700M RX/TA Low]→ [700M RX/TA High]→ [700M TX Low]→ [700M TX High]→ [800M TX Low]→ [800M TX High]→ [800M RX/TA Low]→ [800M RX/TA High] Adjust:[****] PTT : ON Press [O] key to store the adjustment value.	1) Adj item: [Balance] Deviation meter LPF: 3kHz HPF: OFF 2) Adj item: [Frequency: 700MHz Band] [RX/TA Low]→ [RX/TA High]→ [TX Low]→ [TX High] [Frequency: 800MHz Band] [TX Low]→ [TX High]→ [RX/TA Low]→ [RX/TA High] Press [Transmit] button. Press [Apply All] button to store the adjustment value.	Deviation meter Oscilloscope	Panel	ANT	Panel	[Panel tuning mode] [▲], [▼] [PC test mode] [←], [→]	The Deviation of 20Hz frequency is fixed. Change the 2kHz adjustment value to become the same deviation of 20Hz within the specified range. (a supplementary explanation: Another way to adjust is ready. (Same as TK-5910, the old model of NX-5900). Press [AUX(Orange)] key to switch the tone to 100Hz square wave. Then, make the demodulation waveform shown on oscilloscope into square shape.)	2kHz Tone deviation is within ± 1.0% of 20Hz tone deviation. [PC test mode] Press [Apply All] button to store the adjustment value after all adjustment point was adjusted.
*1 : Refer to the "4.9.1 Necessary Deviation adjustment item for each signaling and mode" table. Balance adjustment is common with the adjustment of all signaling deviations.									

Item	Condition		Measurement			Adjustment			Specifications /Remarks
	Panel tuning mode	PC test mode	Test-equipment	Unit	Terminal	Unit	Parts	Method	
13. Maximum Deviation *2 [Analog Wide 5k]	1) Adj item: [Aw ADEV] Adjust:[****] Deviation meter LPF: 15kHz HPF: OFF 2) Adj item: [700M RX/TA Low]→ [700M RX/TA High]→ [700M TX Low]→ [700M TX High]→ [800M TX Low]→ [800M TX High]→ [800M RX/TA Low]→ [800M RX/TA High] Adjust:[****] PTT : ON Press [O] key to store the adjustment value.	1) Adj item: [Maxmum Deviation (Analog Wide 5k)] Deviation meter LPF: 15kHz HPF: OFF 2) Adj item: [Frequency: 700MHz Band] [RX/TA Low]→ [RX/TA High]→ [TX Low]→ [TX High] [Frequency: 800MHz Band] [TX Low]→ [TX High]→ [RX/TA Low]→ [RX/TA High] Press [Transmit] button. Press [Apply All] button to store the adjustment value.	Deviation meter Oscilloscope	Panel	ANT	Panel	[Panel tuning mode] [▲], [▼] [PC test mode] [←], [→]	Write fixed value for each adjustment point. (The value is written below.) Transmit at each adjustment point and check that the deviation is between 4150Hz and 4250Hz. Deviation meter LPF: 15kHz HPF: OFF [Fixed Value] 497 [Panel tuning mode] PTT: ON [PC test mode] PTT: Press [Transmit] button	4150~4250Hz [PC test mode] Press [Apply All] button to store the adjustment value after all adjustment point was adjusted.
[Analog Wide 4k] *2	1) Adj item: [As ADEV] Adjust:[****] Deviation meter LPF: 15kHz HPF: OFF 2) Adj item: [700M RX/TA Low]→ [700M RX/TA High]→ [700M TX Low]→ [700M TX High]→ [800M TX Low]→ [800M TX High]→ [800M RX/TA Low]→ [800M RX/TA High] Adjust:[****] PTT : ON Press [O] key to store the adjustment value.	1) Adj item: [Maxmum Deviation (Analog Wide 4k)] Deviation meter LPF: 15kHz HPF: OFF 2) Adj item: [Frequency: 700MHz Band] [RX/TA Low]→ [RX/TA High]→ [TX Low]→ [TX High] [Frequency: 800MHz Band] [TX Low]→ [TX High]→ [RX/TA Low]→ [RX/TA High] Press [Transmit] button. Press [Apply All] button to store the adjustment value.	Deviation meter Oscilloscope	Panel	ANT	Panel	[Panel tuning mode] [▲], [▼] [PC test mode] [←], [→]	Write fixed value for each adjustment point. (The value is written below.) Transmit at each adjustment point and check that the deviation is between 3310Hz and 3410Hz. Deviation meter LPF: 15kHz HPF: OFF [Fixed Value] 498 [Panel tuning mode] PTT: ON [PC test mode] PTT: Press [Transmit] button	3310~3410Hz [PC test mode] Press [Apply All] button to store the adjustment value after all adjustment point was adjusted.

Item	Condition		Measurement			Adjustment			Specifications /Remarks
	Panel tuning mode	PC test mode	Test-equipment	Unit	Terminal	Unit	Parts	Method	
[Analog Narrow] *2	<p>1) Adj item: [As ADEV] Adjust:[****] Deviation meter LPF: 15kHz HPF: OFF</p> <p>2) Adj item: [700M RX/TA Low]→ [700M RX/TA High]→ [700M TX Low]→ [700M TX High]→ [800M TX Low]→ [800M TX High]→ [800M RX/TA Low]→ [800M RX/TA High] Adjust:[****] PTT : ON Press [O] key to store the adjustment value.</p>	<p>1) Adj item: [Maxmum Deviation (Analog Narrow)] Deviation meter LPF: 15kHz HPF: OFF</p> <p>2) Adj item: [Frequency: 700MHz Band] [RX/TA Low]→ [RX/TA High]→ [TX Low]→ [TX High] [Frequency: 800MHz Band] [TX Low]→ [TX High]→ [RX/TA Low]→ [RX/TA High] Press [Transmit] button. Press [Apply All] button to store the adjustment value.</p>	Deviation meter Oscilloscope	Panel	ANT	Panel	[Panel tuning mode] [▲], [▼] [PC test mode] [←], [→]	<p>Write fixed value for each adjustment point. (The value is written below.) Transmit at each adjustment point and check that the deviation is between 2050Hz and 2150Hz. Deviation meter LPF: 15kHz HPF: OFF</p> <p>[Fixed Value] 495</p> <p>[Panel tuning mode] PTT: ON</p> <p>[PC test mode] PTT: Press [Transmit] button</p>	2050~2150Hz [PC test mode] Press [Apply All] button to store the adjustment value after all adjustment point was adjusted.
<p>*2 : Refer to the "4.9.1 Necessary Deviation adjustment item for each signaling and mode" table. Regarding Maximum Deviation (Analog), it is common with the adjustment of all analog signalings.</p>									
14. P25 High Deviation	<p>1) Adj item: [P1 PDEV] Adjust:[****] Deviation meter LPF: 3kHz HPF: OFF</p> <p>2) Adj item: [700M RX/TA Low]→ [700M RX/TA High]→ [700M TX Low]→ [700M TX High]→ [800M TX Low]→ [800M TX High]→ [800M RX/TA Low]→ [800M RX/TA High] Adjust:[****] PTT : ON Press [O] key to store the adjustment value.</p>	<p>1) Adj item: [P25 High Deviation] Deviation meter LPF: 3kHz HPF: OFF</p> <p>2) Adj item: [Frequency: 700MHz Band] [RX/TA Low]→ [RX/TA High]→ [TX Low]→ [TX High] [Frequency: 800MHz Band] [TX Low]→ [TX High]→ [RX/TA Low]→ [RX/TA High] Press [Transmit] button. Press [Apply All] button to store the adjustment value.</p>	Deviation meter Oscilloscope	Panel	ANT	Panel	[Panel tuning mode] [▲], [▼] [PC test mode] [←], [→]	<p>Write fixed value for each adjustment point. (The value is written below.) Transmit at each adjustment point and check that the deviation is between 2771Hz and 2883Hz. Deviation meter LPF: 3kHz HPF: OFF</p> <p>[Fixed Value] 502</p> <p>[Panel tuning mode] PTT: ON</p> <p>[PC test mode] PTT: Press [Transmit] button</p>	2771~2883Hz [PC test mode] Press [Apply All] button to store the adjustment value after all adjustment point was adjusted.

Item	Condition		Measurement			Adjustment			Specifications /Remarks
	Panel tuning mode	PC test mode	Test-equipment	Unit	Terminal	Unit	Parts	Method	
15. P25 H-CPM Deviation	<p>1) Adj item: [P2 P2DEV] Adjust:[****] Deviation meter LPF: 3kHz HPF: OFF</p> <p>2) Adj item: [700M RX/TA Low]→ [700M RX/TA High]→ [700M TX Low]→ [700M TX High]→ [800M TX Low]→ [800M TX High]→ [800M RX/TA Low]→ [800M RX/TA High] Adjust:[****] PTT : ON Press [O] key to store the adjustment value.</p>	<p>1) Adj item: [P25 H-CPM Deviation] Deviation meter LPF: 3kHz HPF: OFF</p> <p>2) Adj item: [Frequency: 700MHz Band] [RX/TA Low]→ [RX/TA High]→ [TX Low]→ [TX High] [Frequency: 800MHz Band] [TX Low]→ [TX High]→ [RX/TA Low]→ [RX/TA High] Press [Transmit] button. Press [Apply All] button to store the adjustment value.</p>	Deviation meter Oscilloscope	Panel	ANT	Panel	[Panel tuning mode] [▲], [▼] [PC test mode] [←], [→]	<p>Write fixed value for each adjustment point. (The value is written below.) Transmit at each adjustment point and check that the deviation is between 3090Hz and 3215Hz. Deviation meter LPF: 3kHz HPF: OFF</p> <p>[Fixed Value] 482</p> <p>[Panel tuning mode] PTT: ON</p> <p>[PC test mode] PTT: Press [Transmit] button</p>	3090~3215Hz [PC test mode] Press [Apply All] button to store the adjustment value after all adjustment point was adjusted.
16. NXDN High Deviation [NXDN Narrow]	<p>1) Adj item: [Nn NDEV] Adjust:[****] Deviation meter LPF: 3kHz HPF: OFF</p> <p>2) Adj item: [700M RX/TA Low]→ [700M RX/TA High]→ [700M TX Low]→ [700M TX High]→ [800M TX Low]→ [800M TX High]→ [800M RX/TA Low]→ [800M RX/TA High] Adjust:[****] PTT : ON Press [O] key to store the adjustment value.</p>	<p>1) Adj item: [NXDN High Deviation (NXDN Narrow)] Deviation meter LPF: 3kHz HPF: OFF</p> <p>2) Adj item: [Frequency: 700MHz Band] [RX/TA Low]→ [RX/TA High]→ [TX Low]→ [TX High] [Frequency: 800MHz Band] [TX Low]→ [TX High]→ [RX/TA Low]→ [RX/TA High] Press [Transmit] button. Press [Apply All] button to store the adjustment value.</p>	Deviation meter Oscilloscope	Panel	ANT	Panel	[Panel tuning mode] [▲], [▼] [PC test mode] [←], [→]	<p>Write fixed value for each adjustment point. (The value is written below.) Transmit at each adjustment point and check that the Analog deviation is between 2995Hz and 3117Hz. Deviation meter LPF: 3kHz HPF: OFF</p> <p>[Fixed Value] 501</p> <p>[Panel tuning mode] PTT: ON</p> <p>[PC test mode] PTT: Press [Transmit] button</p>	2995~3117Hz [PC test mode] Press [Apply All] button to store the adjustment value after all adjustment point was adjusted.

Item	Condition		Measurement			Adjustment			Specifications /Remarks
	Panel tuning mode	PC test mode	Test-equipment	Unit	Terminal	Unit	Parts	Method	
[NXDN Very Narrow]	<p>1) Adj item: [Nv NDEV] Adjust:[****] Deviation meter LPF: 3kHz HPF: OFF</p> <p>2) Adj item: [700M RX/TA Low]→ [700M RX/TA High]→ [700M TX Low]→ [700M TX High]→ [800M TX Low]→ [800M TX High]→ [800M RX/TA Low]→ [800M RX/TA High] Adjust:[****] PTT : ON Press [O] key to store the adjustment value.</p>	<p>1) Adj item: [NXDN High Deviation (NXDN Very Narrow)] Deviation meter LPF: 3kHz HPF: OFF</p> <p>2) Adj item: [Frequency: 700MHz Band] [RX/TA Low]→ [RX/TA High]→ [TX Low]→ [TX High] [Frequency: 800MHz Band] [TX Low]→ [TX High]→ [RX/TA Low]→ [RX/TA High] Press [Transmit] button. Press [Apply All] button to store the adjustment value.</p>	Deviation meter Oscilloscope	Panel	ANT	Panel	[Panel tuning mode] [▲], [▼] [PC test mode] [←], [→]	<p>Write fixed value for each adjustment point. (The value is written below.) Transmit at each adjustment point and check that the Analog deviation is between 1311Hz and 1363Hz. Deviation meter LPF: 3kHz HPF: OFF</p> <p>[Fixed Value] 501</p> <p>[Panel tuning mode] PTT: ON</p> <p>[PC test mode] PTT: Press [Transmit] button</p>	1311~1363Hz [PC test mode] Press [Apply All] button to store the adjustment value after all adjustment point was adjusted.
17. QT Deviation *3 [Analog Wide 5k]	<p>1) Adj item: [Aw QT] Adjust:[****] Deviation meter LPF: 3kHz HPF: OFF</p> <p>2) Adj item: [700M RX/TA High]→ [700M TA High]→ [800M TX High]→ [800M RX/TA High] Adjust:[****] PTT : ON Press [O] key to store the adjustment value.</p>	<p>1) Adj item: [QT Deviation (Analog Wide 5k)] Deviation meter LPF: 3kHz HPF: OFF</p> <p>2) Adj item: [Frequency: 700MHz Band] [RX/TA High]→ [TA High] [Frequency: 800MHz Band] [TX High]→ [RX/TA High] Press [Transmit] button. Press [Apply All] button to store the adjustment value.</p>	Deviation meter Oscilloscope	Panel	ANT	Panel	[Panel tuning mode] [▲], [▼] [PC test mode] [←], [→]	<p>Write the value as followings. [Fixed Value] 527</p>	0.75kHz±0.05 kHz

Item	Condition		Measurement			Adjustment			Specifications /Remarks
	Panel tuning mode	PC test mode	Test-equipment	Unit	Terminal	Unit	Parts	Method	
[Analog Wide 4k]	<p>1) Adj item: [An QT] Adjust:[****] Deviation meter LPF: 3kHz HPF: OFF</p> <p>2) Adj item: [700M RX/TA High]→ [700M TA High]→ [800M TX High]→ [800M RX/TA High] Adjust:[****] PTT : ON Press [O] key to store the adjustment value.</p>	<p>1) Adj item: [QT Deviation (Analog Wide 4k)] Deviation meter LPF: 3kHz HPF: OFF</p> <p>2) Adj item: [Frequency: 700MHz Band] [RX/TA High]→ [TA High] [Frequency: 800MHz Band] [TX High]→ [RX/TA High] Press [Transmit] button. Press [Apply All] button to store the adjustment value.</p>	Deviation meter Oscilloscope	Panel	ANT	Panel	[Panel tuning mode] [▲], [▼] [PC test mode] [←], [→]	Write the value as followings. [Fixed Value] 525	0.60kHz±0.05 kHz
[Analog Narrow]	<p>1) Adj item: [An QT] Adjust:[****] Deviation meter LPF: 3kHz HPF: OFF</p> <p>2) Adj item: [700M RX/TA High]→ [700M TA High]→ [800M TX High]→ [800M RX/TA High] Adjust:[****] PTT : ON Press [O] key to store the adjustment value.</p>	<p>1) Adj item: [QT Deviation (Analog Narrow)] Deviation meter LPF: 3kHz HPF: OFF</p> <p>2) Adj item: [Frequency: 700MHz Band] [RX/TA High]→ [TA High] [Frequency: 800MHz Band] [TX High]→ [RX/TA High] Press [Transmit] button. Press [Apply All] button to store the adjustment value.</p>	Deviation meter Oscilloscope	Panel	ANT	Panel	[Panel tuning mode] [▲], [▼] [PC test mode] [←], [→]	Write the value as followings. [Fixed Value] 525	0.35kHz±0.05 kHz

Item	Condition		Measurement			Adjustment			Specifications /Remarks
	Panel tuning mode	PC test mode	Test-equipment	Unit	Terminal	Unit	Parts	Method	
18. DQT Deviation *3 [Analog Wide 5k]	<p>1) Adj item: [Aw DQT] Adjust:[****] Deviation meter LPF: 3kHz HPF: OFF</p> <p>2) Adj item: [700M RX/TA High]→ [700M TA High]→ [800M TX High]→ [800M RX/TA High] Adjust:[****] PTT : ON Press [O] key to store the adjustment value.</p>	<p>1) Adj item: [DQT Deviation (Analog Wide 5k)] Deviation meter LPF: 3kHz HPF: OFF</p> <p>2) Adj item: [Frequency: 700MHz Band] [RX/TA High]→ [TA High] [Frequency: 800MHz Band] [TX High]→ [RX/TA High] Press [Transmit] button. Press [Apply All] button to store the adjustment value.</p>	Deviation meter Oscilloscope	Panel	ANT	Panel	[Panel tuning mode] [▲], [▼] [PC test mode] [←], [→]	Write the value as followings. [Fixed Value] 428	0.75kHz±0.05 kHz
[Analog Wide 4k]	<p>1) Adj item: [As DQT] Adjust:[****] Deviation meter LPF: 3kHz HPF: OFF</p> <p>2) Adj item: [700M RX/TA High]→ [700M TA High]→ [800M TX High]→ [800M RX/TA High] Adjust:[****] PTT : ON Press [O] key to store the adjustment value.</p>	<p>1) Adj item: [DQT Deviation (Analog Wide 4k)] Deviation meter LPF: 3kHz HPF: OFF</p> <p>2) Adj item: [Frequency: 700MHz Band] [RX/TA High]→ [TA High] [Frequency: 800MHz Band] [TX High]→ [RX/TA High] Press [Transmit] button. Press [Apply All] button to store the adjustment value.</p>	Deviation meter Oscilloscope	Panel	ANT	Panel	[Panel tuning mode] [▲], [▼] [PC test mode] [←], [→]	Write the value as followings. [Fixed Value] 428	0.60kHz±0.05 kHz

Item	Condition		Measurement			Adjustment			Specifications /Remarks
	Panel tuning mode	PC test mode	Test-equipment	Unit	Terminal	Unit	Parts	Method	
[Analog Narrow]	<p>1) Adj item: [An DQT] Adjust:[****] Deviation meter LPF: 3kHz HPF: OFF</p> <p>2) Adj item: [700M RX/TA High]→ [700M TA High]→ [800M TX High]→ [800M RX/TA High] Adjust:[****] PTT : ON Press [O] key to store the adjustment value.</p>	<p>1) Adj item: [DQT Deviation (Analog Narrow)] Deviation meter LPF: 3kHz HPF: OFF</p> <p>2) Adj item: [Frequency: 700MHz Band] [RX/TA High]→ [TA High] [Frequency: 800MHz Band] [TX High]→ [RX/TA High] Press [Transmit] button. Press [Apply All] button to store the adjustment value.</p>	Deviation meter Oscilloscope	Panel	ANT	Panel	[Panel tuning mode] [▲], [▼] [PC test mode] [←], [→]	Write the value as followings. [Fixed Value] 428	0.35kHz±0.05 kHz
19. LTR Deviation *3 [Analog Wide 5k]	<p>1) Adj item: [Aw LTR] Adjust:[****] Deviation meter LPF: 3kHz HPF: OFF</p> <p>2) Adj item: [700M RX/TA High]→ [700M TA High]→ [800M TX High]→ [800M RX/TA High] Adjust:[****] PTT : ON Press [O] key to store the adjustment value.</p>	<p>1) Adj item: [LTR Deviation (Analog Wide 5k)] Deviation meter LPF: 3kHz HPF: OFF</p> <p>2) Adj item: [Frequency: 700MHz Band] [RX/TA High]→ [TA High] [Frequency: 800MHz Band] [TX High]→ [RX/TA High] Press [Transmit] button. Press [Apply All] button to store the adjustment value.</p>	Deviation meter Oscilloscope	Panel	ANT	Panel	[Panel tuning mode] [▲], [▼] [PC test mode] [←], [→]	Write the value as followings. [Fixed Value] 519	1.00kHz±0.05 kHz

Item	Condition		Measurement			Adjustment			Specifications /Remarks
	Panel tuning mode	PC test mode	Test-equip-ment	Unit	Ter-minal	Unit	Parts	Method	
[Analog Wide 4k]	<p>1) Adj item: [As LTR] Adjust:[****] Deviation meter LPF: 3kHz HPF: OFF</p> <p>2) Adj item: [700M RX/TA High]→ [700M TA High]→ [800M TX High]→ [800M RX/TA High] Adjust:[****] PTT : ON Press [O] key to store the adjustment value.</p>	<p>1) Adj item: [LTR Deviation (Analog Wide 4k)] Deviation meter LPF: 3kHz HPF: OFF</p> <p>2) Adj item: [Frequency: 700MHz Band] [RX/TA High]→ [TA High] [Frequency: 800MHz Band] [TX High]→ [RX/TA High] Press [Transmit] button. Press [Apply All] button to store the adjustment value.</p>	Devia-tion meter Oscil-lo-scope	Panel	ANT	Panel	[Panel tuning mode] [▲], [▼] [PC test mode] [←], [→]	Write the value as followings. [Fixed Value] 519	0.9kHz±0.05k Hz
[Analog Narrow]	<p>1) Adj item: [An LTR] Adjust:[****] Deviation meter LPF: 3kHz HPF: OFF</p> <p>2) Adj item: [700M RX/TA High]→ [700M TA High]→ [800M TX High]→ [800M RX/TA High] Adjust:[****] PTT : ON Press [O] key to store the adjustment value.</p>	<p>1) Adj item: [LTR Deviation (Analog Narrow)] Deviation meter LPF: 3kHz HPF: OFF</p> <p>2) Adj item: [Frequency: 700MHz Band] [RX/TA High]→ [TA High] [Frequency: 800MHz Band] [TX High]→ [RX/TA High] Press [Transmit] button. Press [Apply All] button to store the adjustment value.</p>	Devia-tion meter Oscil-lo-scope	Panel	ANT	Panel	[Panel tuning mode] [▲], [▼] [PC test mode] [←], [→]	Write the value as followings. [Fixed Value] 519	0.75kHz±0.05 kHz

Item	Condition		Measurement			Adjustment			Specifications /Remarks
	Panel tuning mode	PC test mode	Test-equipment	Unit	Terminal	Unit	Parts	Method	
20. DTMF Deviation *3 [Analog Wide 5k]	1) Adj item: [Aw DTMF] Adjust:[****] Deviation meter LPF: 15kHz HPF: OFF 2) Adj item: [700M RX/TA High]→ [700M TA High]→ [800M TX High]→ [800M RX/TA High] Adjust:[****] PTT : ON Press [O] key to store the adjustment value.	1) Adj item: [DTMF Deviation (Analog Wide 5k)] Deviation meter LPF: 15kHz HPF: OFF 2) Adj item: [Frequency: 700MHz Band] [RX/TA High]→ [TA High] [Frequency: 800MHz Band] [TX High]→ [RX/TA High] Press [Transmit] button. Press [Apply All] button to store the adjustment value.	Deviation meter Oscilloscope	Panel	ANT	Panel	[Panel tuning mode] [▲], [▼] [PC test mode] [←], [→]	Write the value as followings. [Fixed Value] 549	2.50kHz±0.05 kHz
[Analog Wide 4k]	1) Adj item: [An DTMF] Adjust:[****] Deviation meter LPF: 15kHz HPF: OFF 2) Adj item: [700M RX/TA High]→ [700M TA High]→ [800M TX High]→ [800M RX/TA High] Adjust:[****] PTT : ON Press [O] key to store the adjustment value.	1) Adj item: [DTMF Deviation (Analog Wide 4k)] Deviation meter LPF: 15kHz HPF: OFF 2) Adj item: [Frequency: 700MHz Band] [RX/TA High]→ [TA High] [Frequency: 800MHz Band] [TX High]→ [RX/TA High] Press [Transmit] button. Press [Apply All] button to store the adjustment value.	Deviation meter Oscilloscope	Panel	ANT	Panel	[Panel tuning mode] [▲], [▼] [PC test mode] [←], [→]	Write the value as followings. [Fixed Value] 549	2.00kHz±0.05 kHz

Item	Condition		Measurement			Adjustment			Specifications /Remarks
	Panel tuning mode	PC test mode	Test-equipment	Unit	Terminal	Unit	Parts	Method	
[Analog Narrow]	<p>1) Adj item: [An DTMF] Adjust:[****] Deviation meter LPF: 15kHz HPF: OFF</p> <p>2) Adj item: [700M RX/TA High]→ [700M TA High]→ [800M TX High]→ [800M RX/TA High] Adjust:[****] PTT : ON Press [O] key to store the adjustment value.</p>	<p>1) Adj item: [DTMF Deviation (Analog Narrow)] Deviation meter LPF: 15kHz HPF: OFF</p> <p>2) Adj item: [Frequency: 700MHz Band] [RX/TA High]→ [TA High] [Frequency: 800MHz Band] [TX High]→ [RX/TA High] Press [Transmit] button. Press [Apply All] button to store the adjustment value.</p>	Deviation meter Oscilloscope	Panel	ANT	Panel	[Panel tuning mode] [▲], [▼] [PC test mode] [←], [→]	Write the value as followings. [Fixed Value] 549	1.25kHz±0.05 kHz
21. Single Tone Deviation [Analog Wide 5k]	<p>1) Adj item: [Aw TONE] Adjust:[****] Deviation meter LPF: 15kHz HPF: OFF</p> <p>2) Adj item: [700M RX/TA High]→ [700M TA High]→ [800M TX High]→ [800M RX/TA High] Adjust:[****] PTT : ON Press [O] key to store the adjustment value.</p>	<p>1) Adj item: [Single Tone Deviation (Analog Wide 5k)] Deviation meter LPF: 15kHz HPF: OFF</p> <p>2) Adj item: [Frequency: 700MHz Band] [RX/TA High]→ [TA High] [Frequency: 800MHz Band] [TX High]→ [RX/TA High] Press [Transmit] button. Press [Apply All] button to store the adjustment value.</p>	Deviation meter Oscilloscope	Panel	ANT	Panel	[Panel tuning mode] [▲], [▼] [PC test mode] [←], [→]	Write the value as followings. [Fixed Value] 515	3.00kHz±0.05 kHz

Item	Condition		Measurement			Adjustment			Specifications /Remarks
	Panel tuning mode	PC test mode	Test-equipment	Unit	Terminal	Unit	Parts	Method	
[Analog Wide 4k]	<p>1) Adj item: [As TONE] Adjust:[****] Deviation meter LPF: 15kHz HPF: OFF</p> <p>2) Adj item: [700M RX/TA High]→ [700M TA High]→ [800M TX High]→ [800M RX/TA High] Adjust:[****] PTT : ON Press [O] key to store the adjustment value.</p>	<p>1) Adj item: [Single Tone Deviation (Analog Wide 4k)] Deviation meter LPF: 15kHz HPF: OFF</p> <p>2) Adj item: [Frequency: 700MHz Band] [RX/TA High]→ [TA High] [Frequency: 800MHz Band] [TX High]→ [RX/TA High] Press [Transmit] button. Press [Apply All] button to store the adjustment value.</p>	Deviation meter Oscilloscope	Panel	ANT	Panel	[Panel tuning mode] [▲], [▼] [PC test mode] [←], [→]	Write the value as followings. [Fixed Value] 515	2.40kHz±0.05 kHz
[Analog Narrow]	<p>1) Adj item: [An TONE] Adjust:[****] Deviation meter LPF: 15kHz HPF: OFF</p> <p>2) Adj item: [700M RX/TA High]→ [700M TA High]→ [800M TX High]→ [800M RX/TA High] Adjust:[****] PTT : ON Press [O] key to store the adjustment value.</p>	<p>1) Adj item: [Single Tone Deviation (Analog Narrow)] Deviation meter LPF: 15kHz HPF: OFF</p> <p>2) Adj item: [Frequency: 700MHz Band] [RX/TA High]→ [TA High] [Frequency: 800MHz Band] [TX High]→ [RX/TA High] Press [Transmit] button. Press [Apply All] button to store the adjustment value.</p>	Deviation meter Oscilloscope	Panel	ANT	Panel	[Panel tuning mode] [▲], [▼] [PC test mode] [←], [→]	Write the value as followings. [Fixed Value] 515	1.50kHz±0.05 kHz

Item	Condition		Measurement			Adjustment			Specifications /Remarks
	Panel tuning mode	PC test mode	Test-equip-ment	Unit	Ter-minal	Unit	Parts	Method	
22. MSK Devia-tion *3 [Analog Wide 5k]	1) Adj item: [Aw MSK] Adjust:[****] Deviation meter LPF: 15kHz HPF: OFF 2) Adj item: [700M RX/TA High]→ [700M TA High]→ [800M TX High]→ [800M RX/TA High] Adjust:[****] PTT : ON Press [O] key to store the adjust-ment value.	1) Adj item: [MSK Deviation (Analog Wide 5k)] Deviation meter LPF: 15kHz HPF: OFF 2) Adj item: [Frequency: 700MHz Band] [RX/TA High]→ [TA High] [Frequency: 800MHz Band] [TX High]→ [RX/TA High] Press [Transmit] button. Press [Apply All] button to store the adjustment value.	Devia-tion meter Oscil-lo-scope	Panel	ANT	Panel	[Panel tuning mode] [▲], [▼] [PC test mode] [←], [→]	Write the value as fol-lowings. [Fixed Value] 504	3.00kHz±0.05 kHz
[Analog Wide 4k]	1) Adj item: [As MSK] Adjust:[****] Deviation meter LPF: 15kHz HPF: OFF 2) Adj item: [700M RX/TA High]→ [700M TA High]→ [800M TX High]→ [800M RX/TA High] Adjust:[****] PTT : ON Press [O] key to store the adjust-ment value.	1) Adj item: [MSK Deviation (Analog Wide 4k)] Deviation meter LPF: 15kHz HPF: OFF 2) Adj item: [Frequency: 700MHz Band] [RX/TA High]→ [TA High] [Frequency: 800MHz Band] [TX High]→ [RX/TA High] Press [Transmit] button. Press [Apply All] button to store the adjustment value.	Devia-tion meter Oscil-lo-scope	Panel	ANT	Panel	[Panel tuning mode] [▲], [▼] [PC test mode] [←], [→]	Write the value as fol-lowings. [Fixed Value] 504	2.40kHz±0.05 kHz

Item	Condition		Measurement			Adjustment			Specifications /Remarks
	Panel tuning mode	PC test mode	Test-equipment	Unit	Terminal	Unit	Parts	Method	
[Analog Narrow]	1) Adj item: [An MSK] Adjust:[****] Deviation meter LPF: 15kHz HPF: OFF 2) Adj item: [700M RX/TA High]→ [700M TA High]→ [800M TX High]→ [800M RX/TA High] Adjust:[****] PTT : ON Press [O] key to store the adjustment value.	1) Adj item: [MSK Deviation (Analog Narrow)] Deviation meter LPF: 15kHz HPF: OFF 2) Adj item: [Frequency: 700MHz Band] [RX/TA High]→ [TA High] [Frequency: 800MHz Band] [TX High]→ [RX/TA High] Press [Transmit] button. Press [Apply All] button to store the adjustment value.	Deviation meter Oscilloscope	Panel	ANT	Panel	[Panel tuning mode] [▲], [▼] [PC test mode] [←], [→]	Write the value as followings. [Fixed Value] 504	1.50kHz±0.05 kHz
23. CWID Deviation *3 [Analog Narrow]	1) Adj item: [An CWID] Adjust:[****] Deviation meter LPF: 15kHz HPF: OFF 2) Adj item: [700M RX/TA High]→ [700M TA High]→ [800M TX High]→ [800M RX/TA High] Adjust:[****] PTT : ON Press [O] key to store the adjustment value.	1) Adj item: [CWID Deviation (Analog Narrow)] Deviation meter LPF: 15kHz HPF: OFF 2) Adj item: [Frequency: 700MHz Band] [RX/TA High]→ [TA High] [Frequency: 800MHz Band] [TX High]→ [RX/TA High] Press [Transmit] button. Press [Apply All] button to store the adjustment value.	Deviation meter Oscilloscope	Panel	ANT	Panel	[Panel tuning mode] [▲], [▼] [PC test mode] [←], [→]	Write the value as followings. [Fixed Value] 502	1.10kHz±0.10 kHz

*3: Refer to the "4.9.1 Necessary Deviation adjustment item for each signaling and mode" table.

4.9.1 Necessary Deviation adjustment item for each signaling and mode

The following shows the necessary adjustment items for each signaling deviation. Please read the following table like the following example. In the case of the signaling "QT (Wide 5k)", this signaling is composed of three elements [Balance, Maximum Deviation (Analog Wide 5k) and QT Deviation (Wide 5k)]. Please adjust Balance and Maximum Deviation (Analog Wide 5k) before adjusting QT Deviation (Wide 5k).

Mode	Signaling	Necessary adjustment and order			
		Wide 5k	Wide 4k	Narrow	Very Narrow
Analog	Audio	1. Balance adjust 2. Maximum Deviation [Analog Wide 5k]	1. Balance adjust 2. Maximum Deviation [Analog Wide 4k]	1. Balance adjust 2. Maximum Deviation [Analog Narrow]	-
	QT	1. Balance adjust 2. Maximum Deviation [Analog Wide 5k] 3. QT Deviation [Analog Wide 5k]	1. Balance adjust 2. Maximum Deviation [Analog Wide 4k] 3. QT Deviation [Analog Wide 4k]	1. Balance adjust 2. Maximum Deviation [Analog Narrow] 3. QT Deviation [Analog Narrow]	-
	DQT	1. Balance adjust 2. Maximum Deviation [Analog Wide 5k] 3. DQT Deviation [Analog Wide 5k]	1. Balance adjust 2. Maximum Deviation [Analog Wide 4k] 3. DQT Deviation [Analog Wide 4k]	1. Balance adjust 2. Maximum Deviation [Analog Narrow] 3. DQT Deviation [Analog Narrow]	-
	LTR	1. Balance adjust 2. Maximum Deviation [Analog Wide 5k] 3. LTR Deviation [Analog Wide 5k]	1. Balance adjust 2. Maximum Deviation [Analog Wide 4k] 3. LTR Deviation [Analog Wide 4k]	1. Balance adjust 2. Maximum Deviation [Analog Narrow] 3. LTR Deviation [Analog Narrow]	-
	DTMF	1. Balance adjust 2. Maximum Deviation [Analog Wide 5k] 3. DTMF Deviation [Analog Wide 5k]	1. Balance adjust 2. Maximum Deviation [Analog Wide 4k] 3. DTMF Deviation [Analog Wide 4k]	1. Balance adjust 2. Maximum Deviation [Analog Narrow] 3. DTMF Deviation [Analog Narrow]	-
	2TONE	1. Balance adjust 2. Maximum Deviation [Analog Wide 5k] 3. Single TONE Deviation [Analog Wide 5k]	1. Balance adjust 2. Maximum Deviation [Analog Wide 4k] 3. Single TONE Deviation [Analog Wide 4k]	1. Balance adjust 2. Maximum Deviation [Analog Narrow] 3. Single TONE Deviation [Analog Narrow]	-
	MSK (Fleet sync)	1. Balance adjust 2. Maximum Deviation [Analog Wide 5k] 3. MSK Deviation [Analog Wide 5k]	1. Balance adjust 2. Maximum Deviation [Analog Wide 4k] 3. MSK Deviation [Analog Wide 4k]	1. Balance adjust 2. Maximum Deviation [Analog Narrow] 3. MSK Deviation [Analog Narrow]	-
P25	-	-	1. Balance adjust 2. P25 High Deviation 3. P25 High Deviation (H-CPM)	-	
NXDN	Audio	-	-	1. Balance adjust 2. High Deviation [NXDN Narrow]	1. Balance adjust 2. High Deviation [NXDN Very Narrow]
	CWID	-	-	-	1. Balance adjust 2. Maximum Deviation [Analog Narrow] 3. CWID Deviation [Very Narrow]

- Balance is common with all the above deviation adjustments. If Balance (Transmitter Section 12) has already adjusted, please skip Step1 and adjust from Step2.
- Maximum Deviation (Analog Wide 5k/Wide 4k/Narrow) is common with all the analog signaling deviations and CWID Deviation (NXDN Very Narrow).
If Balance and Maximum Deviation (Analog Wide 5k/Wide 4k/Narrow) (Transmitter Section 13) have already adjusted, please skip Step2 and adjust from Step3.

4.10 Receiver Section

Item	Condition		Measurement			Adjustment			Specifications /Remarks
	Panel tuning mode	PC test mode	Test-equip-ment	Unit	Ter-minal	Unit	Parts	Method	
1. AF level setting	[Panel test mode] 1) CH-Sig: 1-1 SSG output: -47dBm (1mV) (MOD: 1kHz/ ±1.5kHz)	1) Test Channel Channel: 1 Test Signaling Mode: Analog Signaling: 1 SSG output: -47dBm (1mV) (MOD:1kHz/ ±1.5kHz)	SSG DVM AF VM Dummy load	Panel	ANT Ext. SP con- nector	Panel	[Panel tuning mode] [+], [-] [PC test mode] [←], [→]	Volume Up/Down knob to obtain 1.41V AF output. (0.5W @ 4Ω load)	1.41V ±0.1V
2. RSSI reference [Analog Narrow]	1) Adj item: [An RRSSI] Adjust:[**] 2) Adj item: [700M RX/TA Low]→ [700M RX/TA Center]→ [700M RX/TA High]→ [800M RX/TA Low]→ [800M RX/TA Ceter]→ [800M RX/TA High] SSG output: 12dB SINAD level -3dB (MOD: 1kHz/ ±1.5kHz)	1) Adj item: [RSSI Reference (Analog Narrow)] 2) Adj item: [Frequency: 700 MHz Band] [RX/TA Low]→ [RX/TA Center]→ [RX/TA High] [Frequency: 800MHz Band] [RX/TA Low]→ [RX/TA Ceter]→ [RX/TA High] SSG output: 12dB SINAD level -3dB (MOD: 1kHz/ ±1.5kHz)	SSG Distor- tion meter Oscil- loscop	Panel	ANT Ext. SP con- nector	Panel	[Panel tuning mode] After input signal from SSG, press [O] key to store the adjustment val- ue. PC test mode] After input signal from SSG, press [Apply] button to store the adjustment value.		
3. Open Squelch [Analog Wide 5k]	1) Adj item: [Aw SQL] Adjust:[**] 2) Adj item: [700M RX/TA Low]→ [700M RX/TA Center]→ [700M RX/TA High]→ [800M RX/TA Low]→ [800M RX/TA Ceter]→ [800M RX/TA High] SSG output: 12dB SINAD level -3dB (MOD: 1kHz/ ±3kHz)	1) Adj item: [Open Squelch (Analog Wide 5k)] 2) Adj item: [Frequency: 700 MHz Band] [RX/TA Low]→ [RX/TA Center]→ [RX/TA High] [Frequency: 800MHz Band] [RX/TA Low]→ [RX/TA Ceter]→ [RX/TA High] SSG output: 12dB SINAD level -3dB (MOD: 1kHz/±3kHz)	SSG Distor- tion meter Oscil- loscop	Panel	ANT Ext. SP con- nector	Panel	[Panel tuning mode] After input signal from SSG, press [O] key to store the adjustment val- ue. [PC test mode] After input signal from SSG, press [Apply] button to store the adjustment value.		

Item	Condition		Measurement			Adjustment			Specifications/Remarks
	Panel tuning mode	PC test mode	Test-equipment	Unit	Terminal	Unit	Parts	Method	
[Analog Wide 4k]	1) Adj item: [As SQL] Adjust:[***] 2) Adj item: [700M RX/TA Low]→ [700M RX/TA Center]→ [700M RX/TA High]→ [800M RX/TA Low]→ [800M RX/TA Ceter]→ [800M RX/TA High] SSG output: 12dB SINAD level -3dB (MOD: 1kHz/ ±2.4kHz)	1) Adj item: [Open Squelch (Analog Wide 4k)] 2) Adj item: [Frequency: 700 MHz Band] [RX/TA Low]→ [RX/TA Center]→ [RX/TA High] [Frequency: 800MHz Band] [RX/TA Low]→ [RX/TA Ceter]→ [RX/TA High] SSG output: 12dB SINAD level -3dB (MOD: 1kHz/ ±2.4kHz)	SSG Distortion meter Oscilloscope	Panel	ANT Ext. SP connector	Panel		[Panel tuning mode] After input signal from SSG, press [O] key to store the adjustment value. [PC test mode] After input signal from SSG, press [Apply] button to store the adjustment value.	
[Analog Narrow]	1) Adj item: [An SQL] Adjust:[***] 2) Adj item: [700M RX/TA Low]→ [700M RX/TA Center]→ [700M RX/TA High]→ [800M RX/TA Low]→ [800M RX/TA Ceter]→ [800M RX/TA High] SSG output: 12dB SINAD level -3dB (MOD: 1kHz/ ±1.5kHz)	1) Adj item: [Open Squelch (Analog Narrow)] 2) Adj item: [Frequency: 700 MHz Band] [RX/TA Low]→ [RX/TA Center]→ [RX/TA High] [Frequency: 800MHz Band] [RX/TA Low]→ [RX/TA Ceter]→ [RX/TA High] SSG output: 12dB SINAD level -3dB (MOD: 1kHz/ ±1.5kHz)	SSG Distortion meter Oscilloscope	Panel	ANT Ext. SP connector	Panel		[Panel tuning mode] After input signal from SSG, press [O] key to store the adjustment value. [PC test mode] After input signal from SSG, press [Apply] button to store the adjustment value.	

Item	Condition		Measurement			Adjustment			Specifications /Remarks
	Panel tuning mode	PC test mode	Test-equip-ment	Unit	Ter-minal	Unit	Parts	Method	
[P25 (C4FM)]	1) Adj item: [P1 SQL] Adjust:[***] 2) Adj item: [700M RX/TA Low]→ [700M RX/TA Center]→ [700M RX/TA High]→ [800M RX/TA Low]→ [800M RX/TA Ceter]→ [800M RX/TA High] SSG output: 12dB SINAD level at Analog Narrow -1dB (MOD: 1kHz/ ±2.2kHz)	1) Adj item: [Open Squelch (P25 C4FM)] 2) Adj item: [Frequency: 700 MHz Band] [RX/TA Low]→ [RX/TA Center]→ [RX/TA High] [Frequency: 800MHz Band] [RX/TA Low]→ [RX/TA Ceter]→ [RX/TA High] SSG output: 12dB SINAD level at Analog Narrow -1dB (MOD: 1kHz/ ±2.2kHz)	SSG Distortion meter Oscillo-scope	Panel	ANT Ext. SP con- nector	Panel		[Panel tuning mode] After input signal from SSG, press [O] key to store the adjustment value. [PC test mode] After input signal from SSG, press [Apply] button to store the adjustment value.	
[P25 (LSM)]	1) Adj item: [P1 SQL] Adjust:[***] 2) Adj item: [700M RX/TA Low]→ [700M RX/TA Center]→ [700M RX/TA High]→ [800M RX/TA Low]→ [800M RX/TA Ceter]→ [800M RX/TA High] SSG output: 12dB SINAD level at Analog Narrow -3dB (MOD: 1kHz/ ±3.3kHz)	1) Adj item: [Open Squelch (P25 LSM)] 2) Adj item: [Frequency: 700 MHz Band] [RX/TA Low]→ [RX/TA Center]→ [RX/TA High] [Frequency: 800MHz Band] [RX/TA Low]→ [RX/TA Ceter]→ [RX/TA High] SSG output: 12dB SINAD level at Analog Narrow -3dB (MOD: 1kHz/ ±3.3kHz)	SSG Distortion meter Oscillo-scope	Panel	ANT Ext. SP con- nector	Panel		[Panel tuning mode] After input signal from SSG, press [O] key to store the adjustment value. [PC test mode] After input signal from SSG, press [Apply] button to store the adjustment value.	

Item	Condition		Measurement			Adjustment			Specifications/Remarks
	Panel tuning mode	PC test mode	Test-equipment	Unit	Terminal	Unit	Parts	Method	
[NXDN Narrow]	1) Adj item: [Nn SQL] Adjust:[***] 2) Adj item: [700M RX/TA Low]→ [700M RX/TA Center]→ [700M RX/TA High]→ [800M RX/TA Low]→ [800M RX/TA Ceter]→ [800M RX/TA High] SSG output: 12dB SINAD level at Analog Narrow -1dB (MOD: 400Hz/±2.5kHz)	1) Adj item: [Open Squelch (NXDN Narrow)] 2) Adj item: [Frequency: 700 MHz Band] [RX/TA Low]→ [RX/TA Center]→ [RX/TA High] [Frequency: 800MHz Band] [RX/TA Low]→ [RX/TA Ceter]→ [RX/TA High] SSG output: 12dB SINAD level at Analog Narrow -1dB (MOD: 400Hz/±2.5kHz)	SSG Distortion meter Oscilloscope	Panel	ANT Ext. SP connector	Panel		[Panel tuning mode] After input signal from SSG, press [O] key to store the adjustment value. [PC test mode] After input signal from SSG, press [Apply] button to store the adjustment value.	
[NXDN Very Narrow]	1) Adj item: [Nv SQL] Adjust:[***] 2) Adj item: [700M RX/TA Low]→ [700M RX/TA Center]→ [700M RX/TA High]→ [800M RX/TA Low]→ [800RX/TA Ceter]→ [800M RX/TA High] SSG output: 12dB SINAD level at Analog Narrow -3dB (MOD: 400Hz/±1.2kHz)	1) Adj item: [Open Squelch (NXDN Very Narrow)] 2) Adj item: [Frequency: 700 MHz Band] [RX/TA Low]→ [RX/TA Center]→ [RX/TA High] [Frequency: 800MHz Band] [RX/TA Low]→ [RX/TA Ceter]→ [RX/TA High] SSG output: 12dB SINAD level at Analog Narrow -3dB (MOD: 400Hz/±1.2kHz)	SSG Distortion meter Oscilloscope	Panel	ANT Ext. SP connector	Panel		[Panel tuning mode] After input signal from SSG, press [O] key to store the adjustment value. [PC test mode] After input signal from SSG, press [Apply] button to store the adjustment value.	

Item	Condition		Measurement			Adjustment			Specifications /Remarks
	Panel tuning mode	PC test mode	Test-equip-ment	Unit	Ter-minal	Unit	Parts	Method	
4. Low RSSI [Analog Narrow]	1) Adj item: [An LRSSI] Adjust:[***] 2) Adj item: [700M RX/TA Low]→ [700M RX/TA Center]→ [700M RX/TA High]→ [800M RX/TA Low]→ [800M RX/TA Ceter]→ [800M RX/TA High] SSG output: -118dB(0.28μV) (MOD: 1kHz/ ±1.5kHz)	1) Adj item: [Low RSSI (Analog Narrow)] 2) Adj item: [Frequency: 700 MHz Band] [RX/TA Low]→ [RX/TA Center]→ [RX/TA High] [Frequency: 800MHz Band] [RX/TA Low]→ [RX/TA Ceter]→ [RX/TA High] SSG output: -118dB(0.28μV) (MOD: 1kHz/ ±1.5kHz)	SSG	Panel	ANT Ext. SP con- nector	Panel		<p>[Panel tuning mode] After input signal from SSG, press [O] key to store the adjustment value.</p> <p>[PC test mode] After input signal from SSG, press [Apply] button to store the adjustment value.</p>	
5. High RSSI [Analog Narrow]	1) Adj item: [An HRSSI] Adjust:[***] 2) Adj item: [700M RX/TA Low]→ [700M RX/TA Center]→ [700M RX/TA High]→ [800M RX/TA Low]→ [800M RX/TA Ceter]→ [800M RX/TA High] SSG output: -80dB(22.4μV) (MOD: 1kHz/ ±1.5kHz)	1) Adj item: [High RSSI (Analog Narrow)] 2) Adj item: [Frequency: 700 MHz Band] [RX/TA Low]→ [RX/TA Center]→ [RX/TA High] [Frequency: 800MHz Band] [RX/TA Low]→ [RX/TA Ceter]→ [RX/TA High] SSG output: -80dB(22.4μV) (MOD: 1kHz/ ±1.5kHz)	SSG	Panel	ANT Ext. SP con- nector	Panel		<p>[Panel tuning mode] After input signal from SSG, press [O] key to store the adjustment value.</p> <p>[PC test mode] After input signal from SSG, press [Apply] button to store the adjustment value.</p>	

Item	Condition		Measurement			Adjustment			Specifications/Remarks
	Panel tuning mode	PC test mode	Test-equipment	Unit	Terminal	Unit	Parts	Method	
6. Tight Squelch [Analog Wide 5k]	1) Adj item: [Aw SQLT] Adjust:[***] 2) Adj item: [700M RX/TA Low]→ [700M RX/TA Center]→ [700M RX/TA High]→ [800M RX/TA Low]→ [800M RX/TA Ceter]→ [800M RX/TA High] SSG output: 12dB SINAD level at Analog Wide 5k +6dB (MOD: 1kHz/±3kHz)	1) Adj item: [Tight Squelch (Analog Wide 5k)] 2) Adj item: [Frequency: 700 MHz Band] [RX/TA Low]→ [RX/TA Center]→ [RX/TA High] [Frequency: 800MHz Band] [RX/TA Low]→ [RX/TA Ceter]→ [RX/TA High] SSG output: 12dB SINAD level at Analog Wide 5k +6dB (MOD: 1kHz/±3kHz)	SSG Distortion meter Oscilloscope	Panel	ANT Ext. SP connector	Panel		[Panel tuning mode] After input signal from SSG, press [O] key to store the adjustment value. [PC test mode] After input signal from SSG, press [Apply] button to store the adjustment value.	
[Analog Wide 4k]	1) Adj item: [As SQLT] Adjust:[***] 2) Adj item: [700M RX/TA Low]→ [700M RX/TA Center]→ [700M RX/TA High]→ [800M RX/TA Low]→ [800M RX/TA Ceter]→ [800M RX/TA High] SSG output: 12dB SINAD level at Analog Wide 4k +6dB (MOD: 1kHz/±2.4kHz)	1) Adj item: [Tight Squelch (Analog Wide 4k)] 2) Adj item: [Frequency: 700 MHz Band] [RX/TA Low]→ [RX/TA Center]→ [RX/TA High] [Frequency: 800MHz Band] [RX/TA Low]→ [RX/TA Ceter]→ [RX/TA High] SSG output: 12dB SINAD level at Analog Wide 4k +6dB (MOD: 1kHz/±2.4kHz)	SSG Distortion meter Oscilloscope	Panel	ANT Ext. SP connector	Panel		[Panel tuning mode] After input signal from SSG, press [O] key to store the adjustment value. [PC test mode] After input signal from SSG, press [Apply] button to store the adjustment value.	

Item	Condition		Measurement			Adjustment			Specifications /Remarks
	Panel tuning mode	PC test mode	Test-equip-ment	Unit	Ter-minal	Unit	Parts	Method	
[Analog Narrow]	1) Adj item: [As SQLT] Adjust:[***] 2) Adj item: [700M RX/TA Low]→ [700M RX/TA Center]→ [700M RX/TA High]→ [800M RX/TA Low]→ [800M RX/TA Ceter]→ [800M RX/TA High] SSG output: 12dB SINAD level at Analog Narrow +6dB (MOD: 1kHz/ ±1.5kHz)	1) Adj item: [Tight Squelch (Analog Narrow)] 2) Adj item: [Frequency: 700 MHz Band] [RX/TA Low]→ [RX/TA Center]→ [RX/TA High] [Frequency: 800MHz Band] [RX/TA Low]→ [RX/TA Ceter]→ [RX/TA High] SSG output: 12dB SINAD level at Analog Narrow +6dB (MOD: 1kHz/ ±1.5kHz)	SSG Distortion meter Oscilloscope	Panel	ANT Ext. SP con- nector	Panel		[Panel tuning mode] After input signal from SSG, press [O] key to store the adjustment value. [PC test mode] After input signal from SSG, press [Apply] button to store the adjustment value.	

SECTION 5 TROUBLESHOOTING

5.1 Fault Diagnosis of the BGA (Ball Grid Array) IC

■ Overview

A flowchart for determining whether or not the transceiver can be powered on (the LCD does not function even if the power switch is turned on) due to broken BGA parts.

■ BGA parts

MPU/DSP (IC706), mobile DDR (IC702), Flash memory (IC701)

When the BGA IC is problematic, please bring the printed circuit board (XC1-1021-81) in for service. Various ESN/ default adjustment values are written on the printed circuit board for service.

Additionally various ESN stickers are included. (Please refer to "5.4 Replacing Main Unit".)

After the printed circuit board has been readjusted, please attach any ESN stickers to the chassis. When "ESN Validation" is used, you must modify the ESN register.

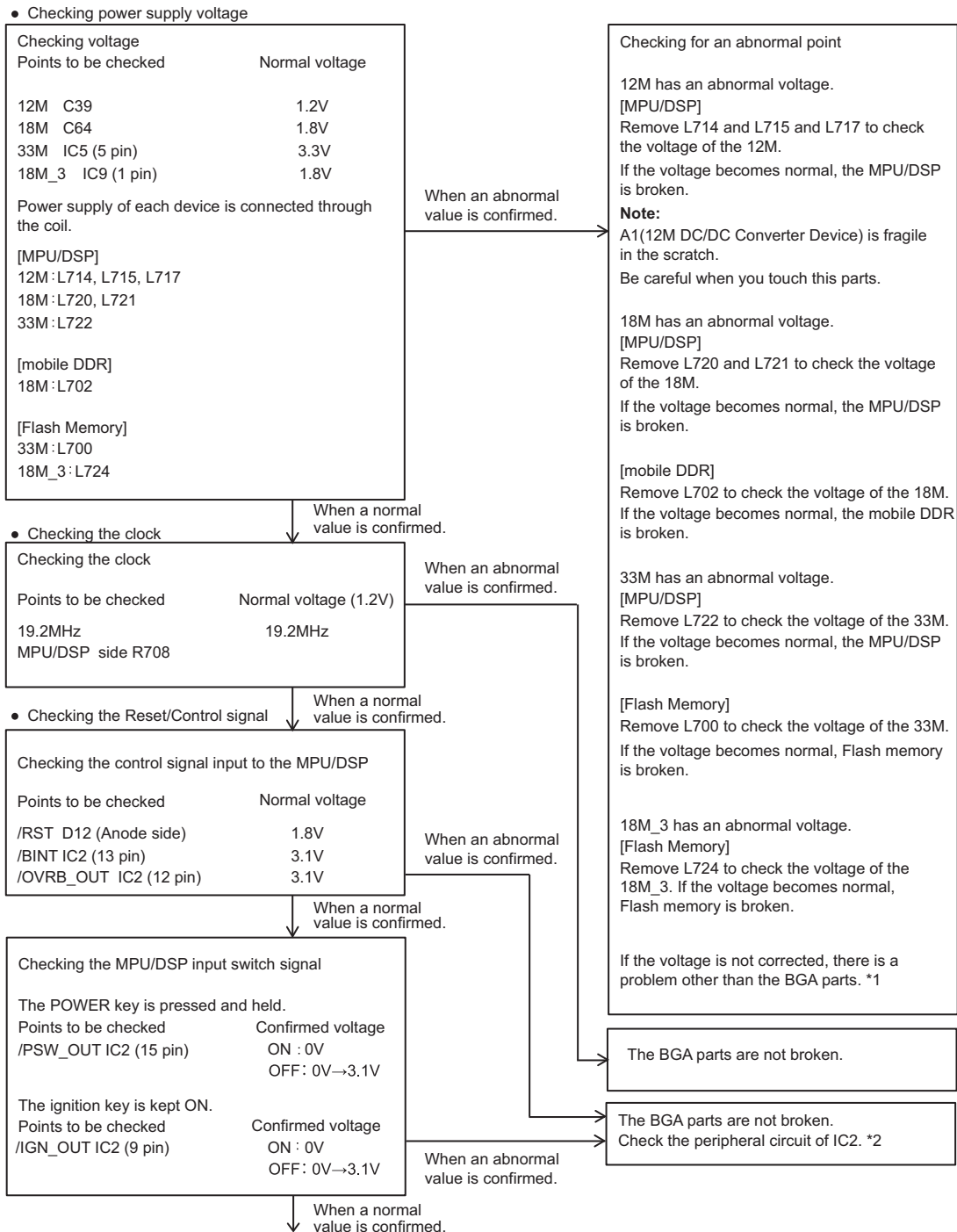

- Checking the output signal from the MPU/DSP.

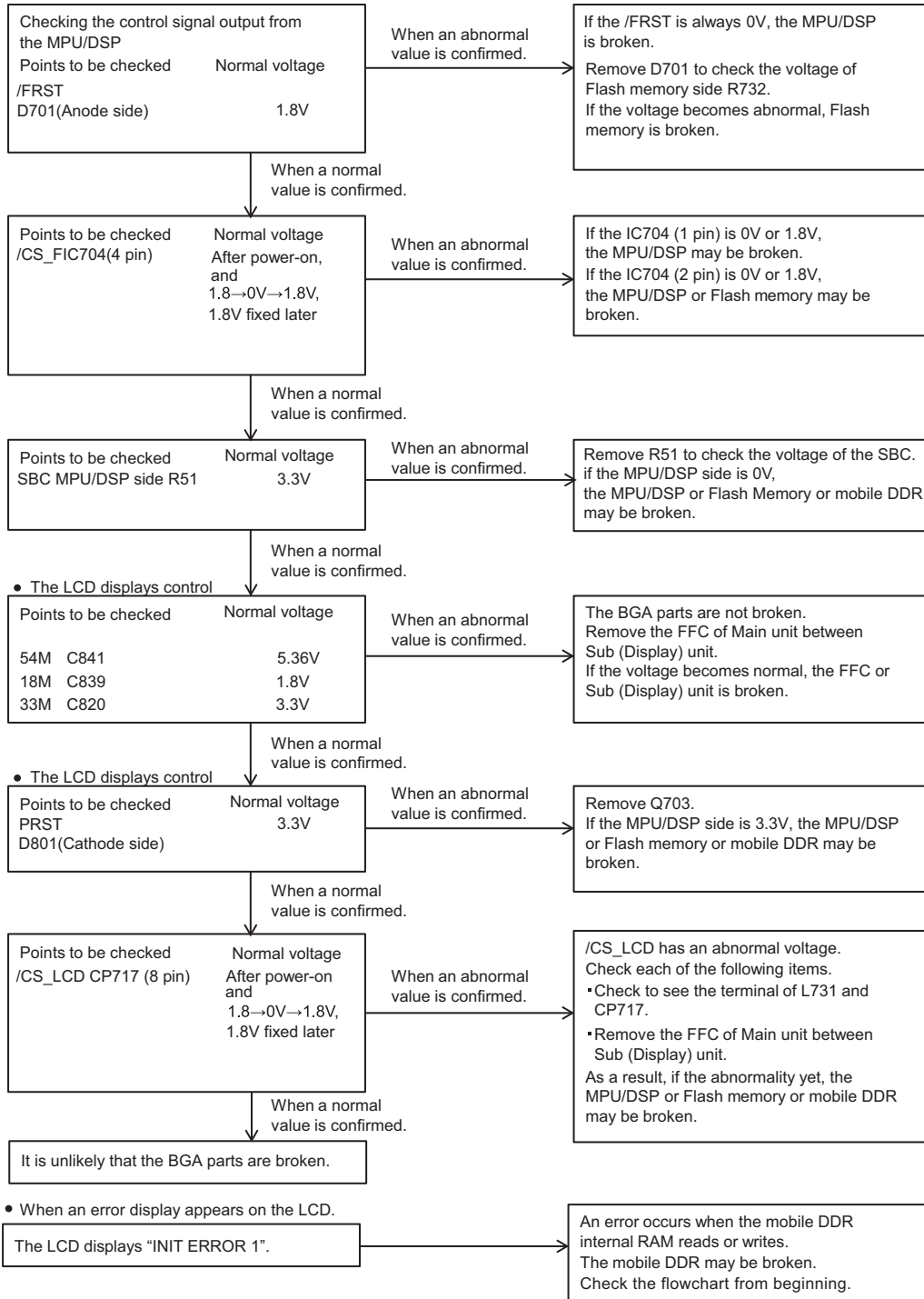

■ Descriptions of signal names

(1) /RST	:MPU/DSP reset signal	LOW → Reset
(2) /BINT	:Battery final voltage monitoring	LOW → Final voltage
(3) /OVRB_OUT	:Battery overvoltage monitoring	LOW → Overvoltage
(4) /PSW_OUT	:Power switch signal	LOW → ON
(5) /IGN_OUT	:Ignition switch signal	LOW → ON
(6) /FRST	:Flash Memory reset signal	LOW → Reset
(7) /CS_F	:Flash Memory chip select signal	LOW → Active
(8) SBC	:Switch +B control	HIGH → ON
(9) 30LCD	:LCD module control 3.0V power supply	
(10) PRST	:LCD reset signal	LOW → Reset
(11) /CS_LCD	:LCD controller chip select signal	LOW → Active

*1 If 12M, 18M or 33M has still abnormal voltage after the implementation of each procedure above, 54M(IC8), 12M(A1), 18M(IC11), 33M(IC5) or one of these peripheral circuit is broken.
54M (normally 5.4V at L12) has an abnormal voltage, check the MSP430G25KGCA (IC2) according to the following procedure.

● Checking the operation of the IC2

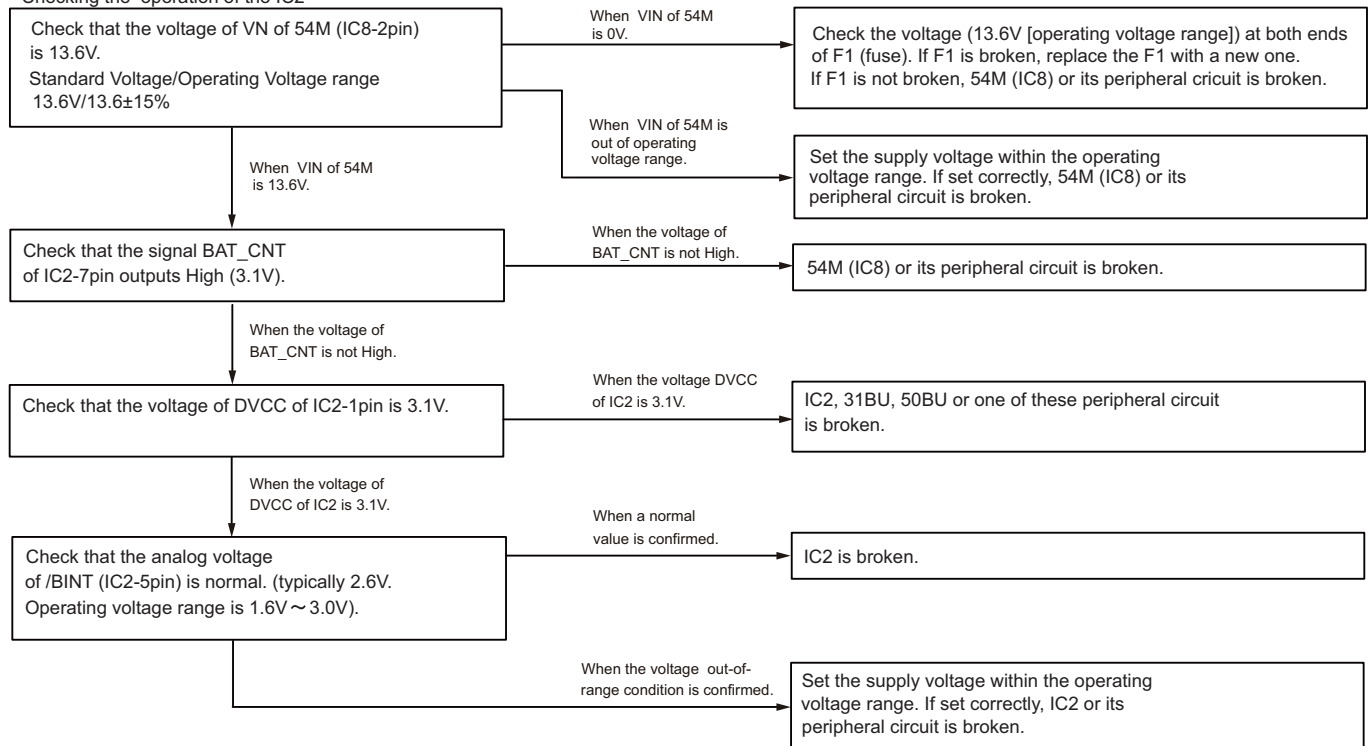

*2 ● Checking the operation of the IC2 (/RST)

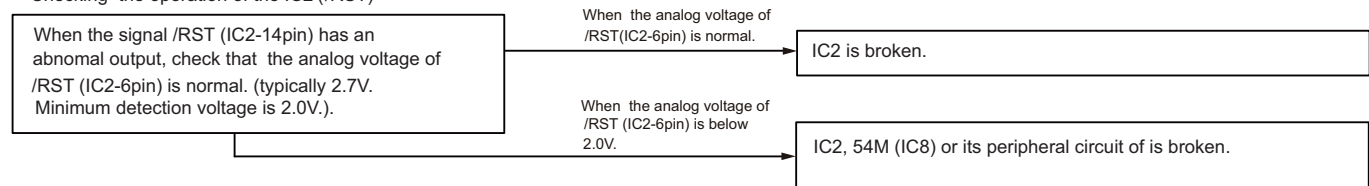

● Checking the operation of the IC2 (/BINT)

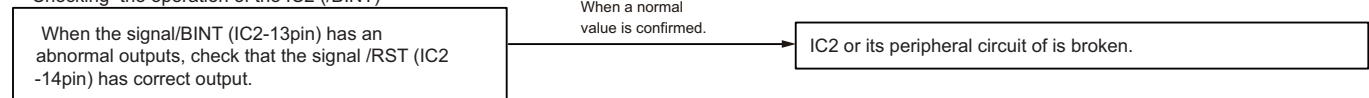

● Checking the operation of the IC2 (/OVRB_OUT)

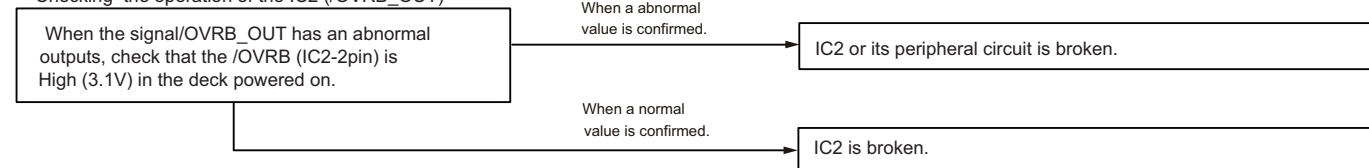

- Checking the operation of IC2 (/PSW and /IGN)
Check that the signal /PSW (IC2-10pin) and /PSW_OUT (IC2-15pin) are linked with the power button on KCH-19 in power on state.

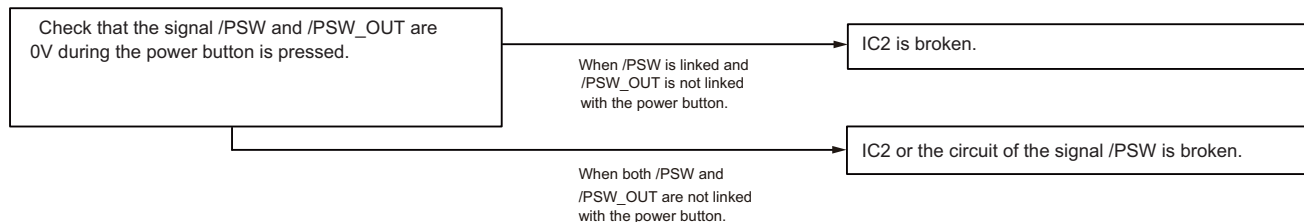

If the ignition function is enabled, check that the signal /IGN (IC2-8pin) and /IGN_OUT (IC2-9pin) are linked with the ignition sense.

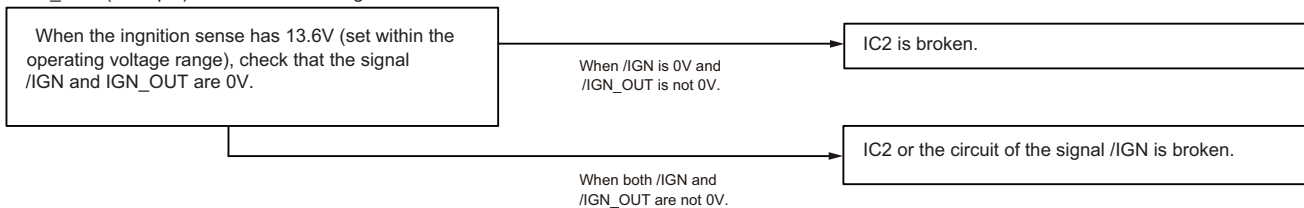

■Remarks related MSP430G25KGCA

- MSP430G25KGCA is written the program.
- OMAP communicates with MSP43G25KGCA by serial communication at startup of deck.
Only firmware version of MSP43G25KGCA is confirmed OMAP in serial communication.
Even when firmware version of MSP43G25KGCA can not be acquired, the system of MSP43G25KGCA is started.
- If there is the difference of firmware version of MSP43G25KGCA between MSP43G25KGCA and OMAP, the firmware version of MSP43G25KGCA is updated with the serial communication by OMAP.
"WAIT..." is displayed on the LCD during the firmware update. When the firmware update fails, the system of MSP43G25KGCA is started and OMAP is trying to update again at next startup.

5.2 Failure diagnosis of the GPS section

Over view:

When the GPS function does not operate, use this flowchart to determine the problem.

Major parts for a GPS circuit

- GPS antenna (KRA-40 (option))
- Coaxial cable (E0E-0003-00)
- SAW Filter (L9)
- Bluetooth/GPS IC (IC5)
- Level conversion IC (IC6,IC7)
- TCXO 19.2MHz (X1)
- 32.768kHz clock (X2)
- 33BT Regulator (IC3)
- 18BT Regulator (IC2)
- 33GPS Regulator (IC4)
- MPU/DSP IC (IC706)

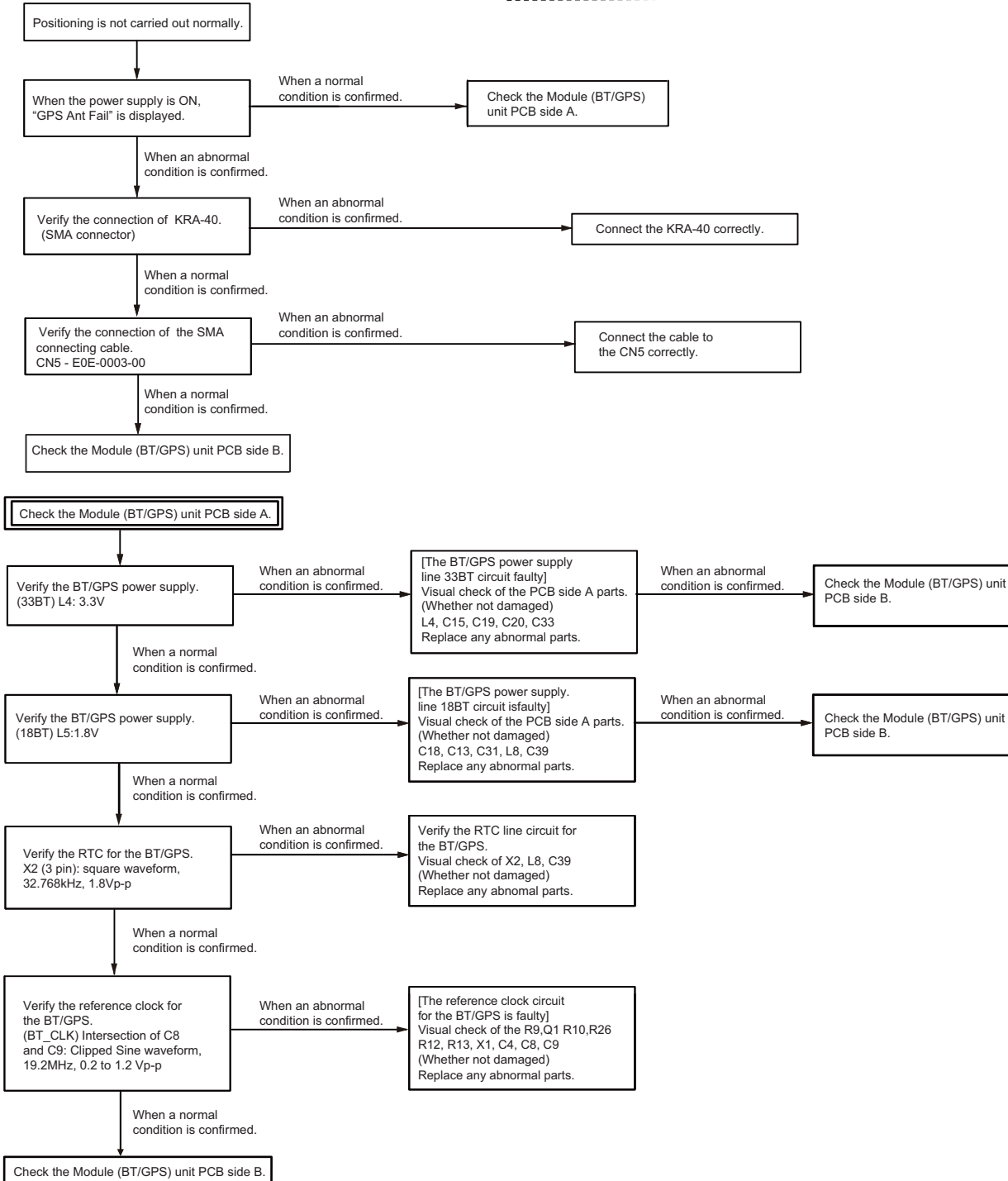
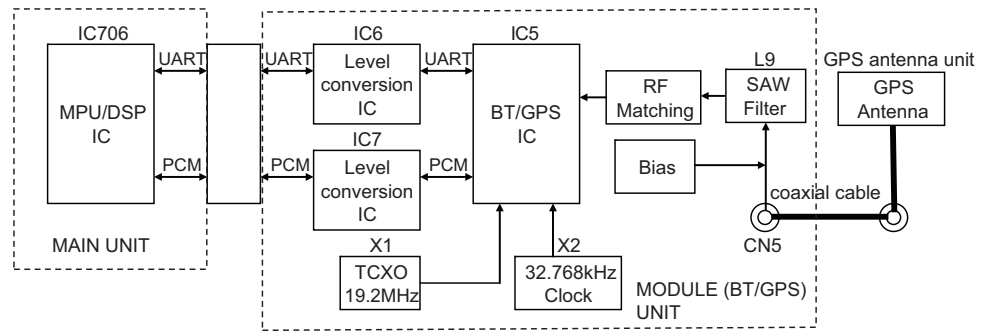

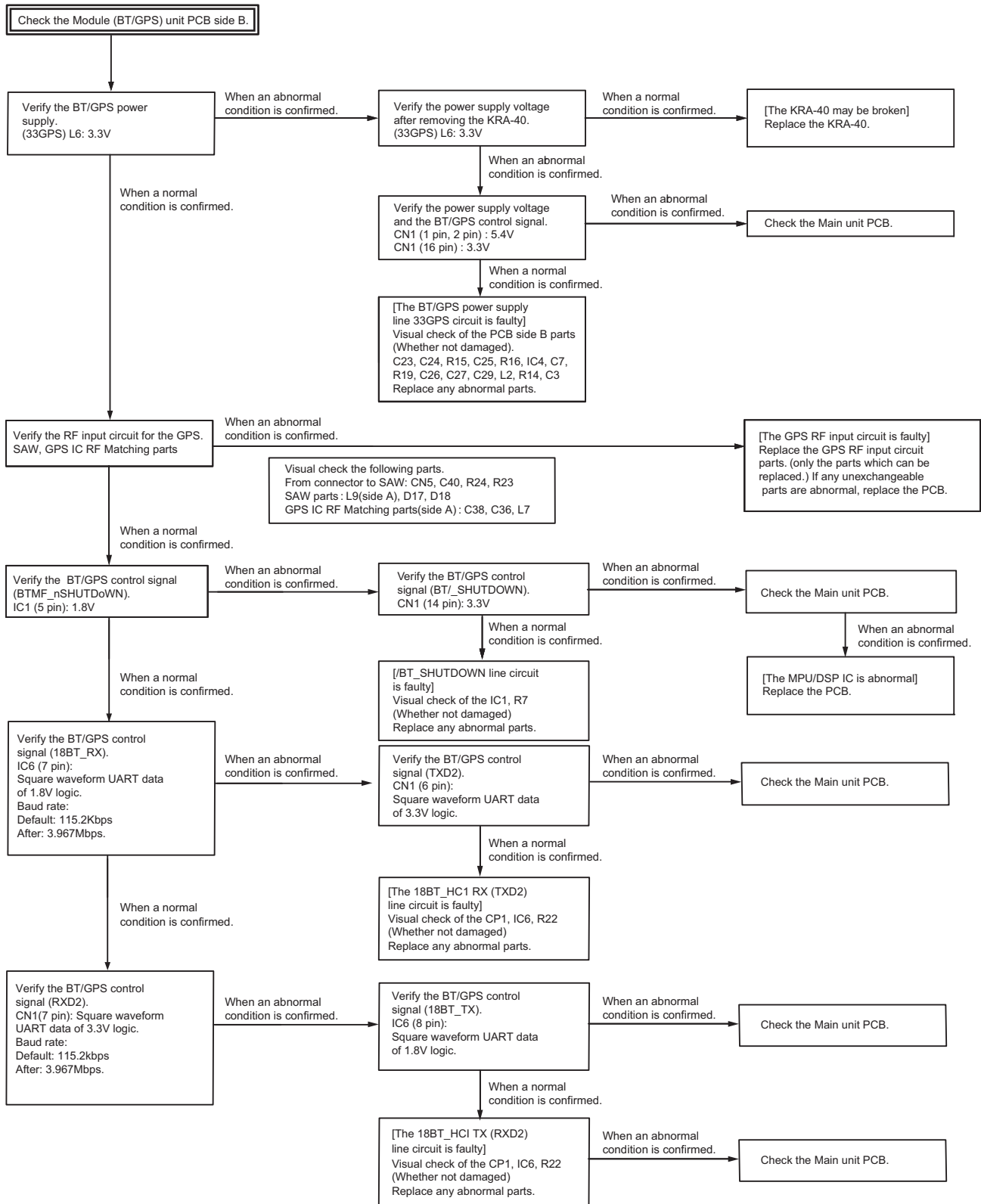

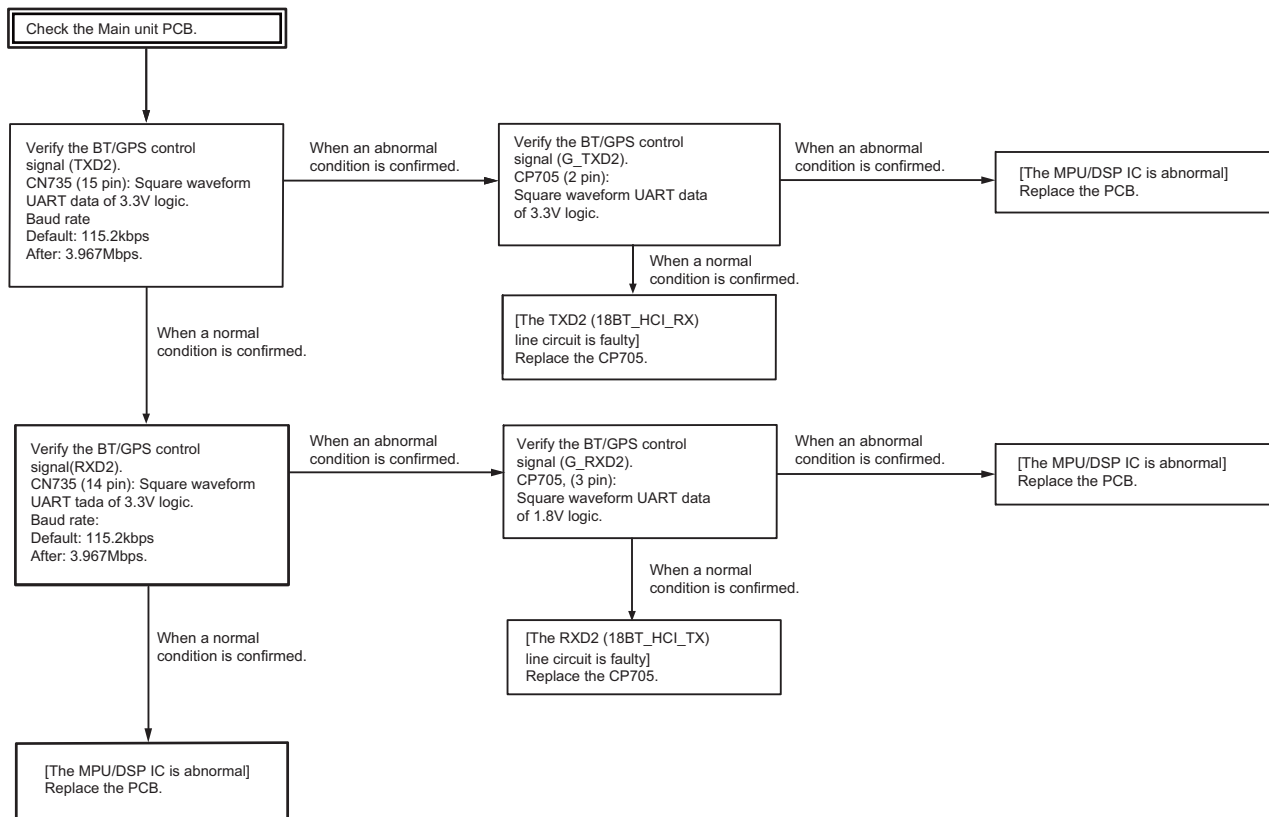

■ Descriptions of signal names

- (1) 33BT: BT/GPS IC 3.3V power supply
- (2) 18BT: BT/GPS IC 1.8V power supply
- (3) 33GPS: BT/GPS IC 3.3V power supply
- (4) TXD2: BT/GPS serial data line connected to UART TX of MPU/DSP IC (MPU/DSP to BT/GPS IC)
- (5) RXD2: BT/GPS serial data line connected to UART RX of MPU/DSP IC (MPU/DSP to BT/GPS IC)
- (6) 18BT_HCI_RX: BT/GPS serial data line connected to UART RX of BT/GPS IC (MPU to BT/GPS IC)
- (7) 18BT_HCI_TX: BT/GPS serial data line connected to UART TX of GPS IC (BT/GPS IC to MPU)
- (8) /BT_SHUTDOWN: BT/GPS active control of MPU/DSP IC (MPU/DSP to BT/GPS IC) High → Active, Low → Reset

5.3 Failure diagnosis of the Bluetooth section

Over view:

When the Bluetooth function does not operate, use this flowchart to determine the problem.

Major parts for a Bluetooth circuit

- Bluetooth antenna (Pattern Antenna)
- LC filter (L11)
- Bluetooth/GPS IC (IC5)
- Level conversion IC (IC6, IC7)
- TCXO 19.2MHz (X1)
- 32.768kHz clock (X2)
- 33BT Regulator (IC3)
- 18BT Regulator (IC2)
- MPU/DSP IC (IC706)

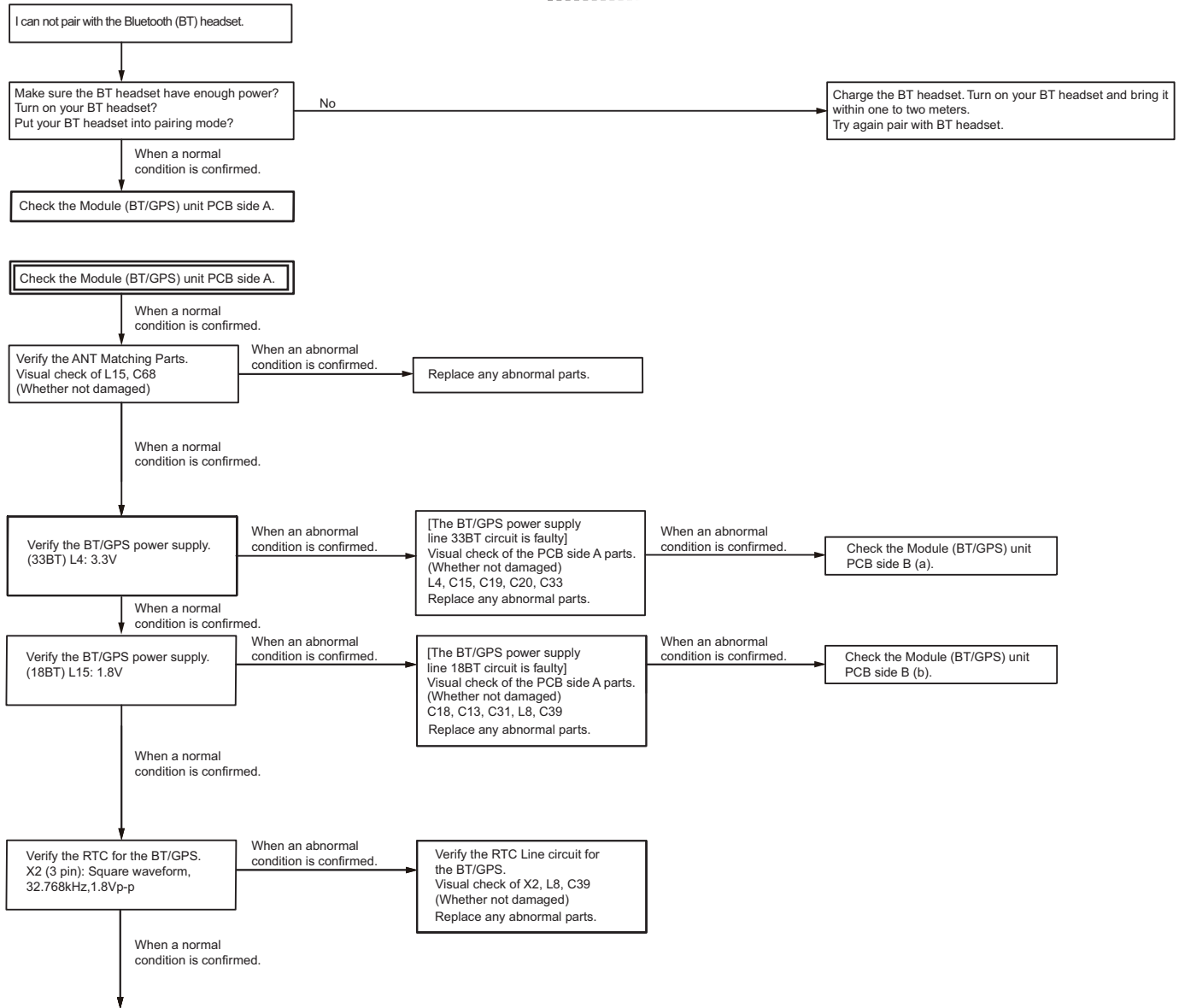
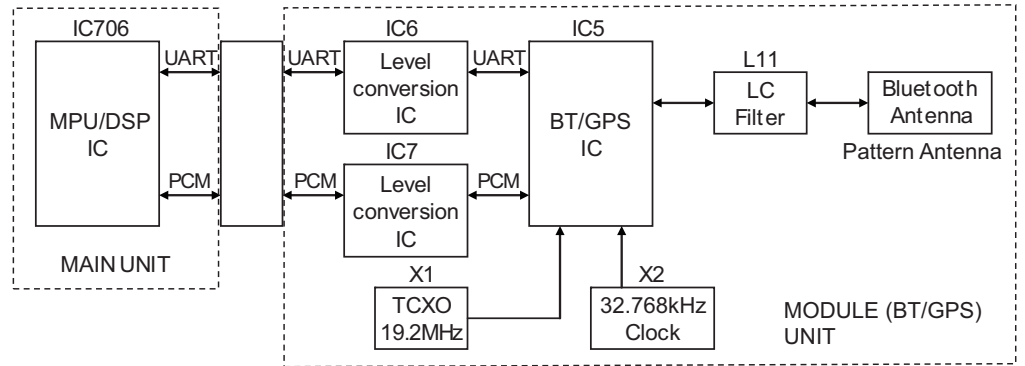

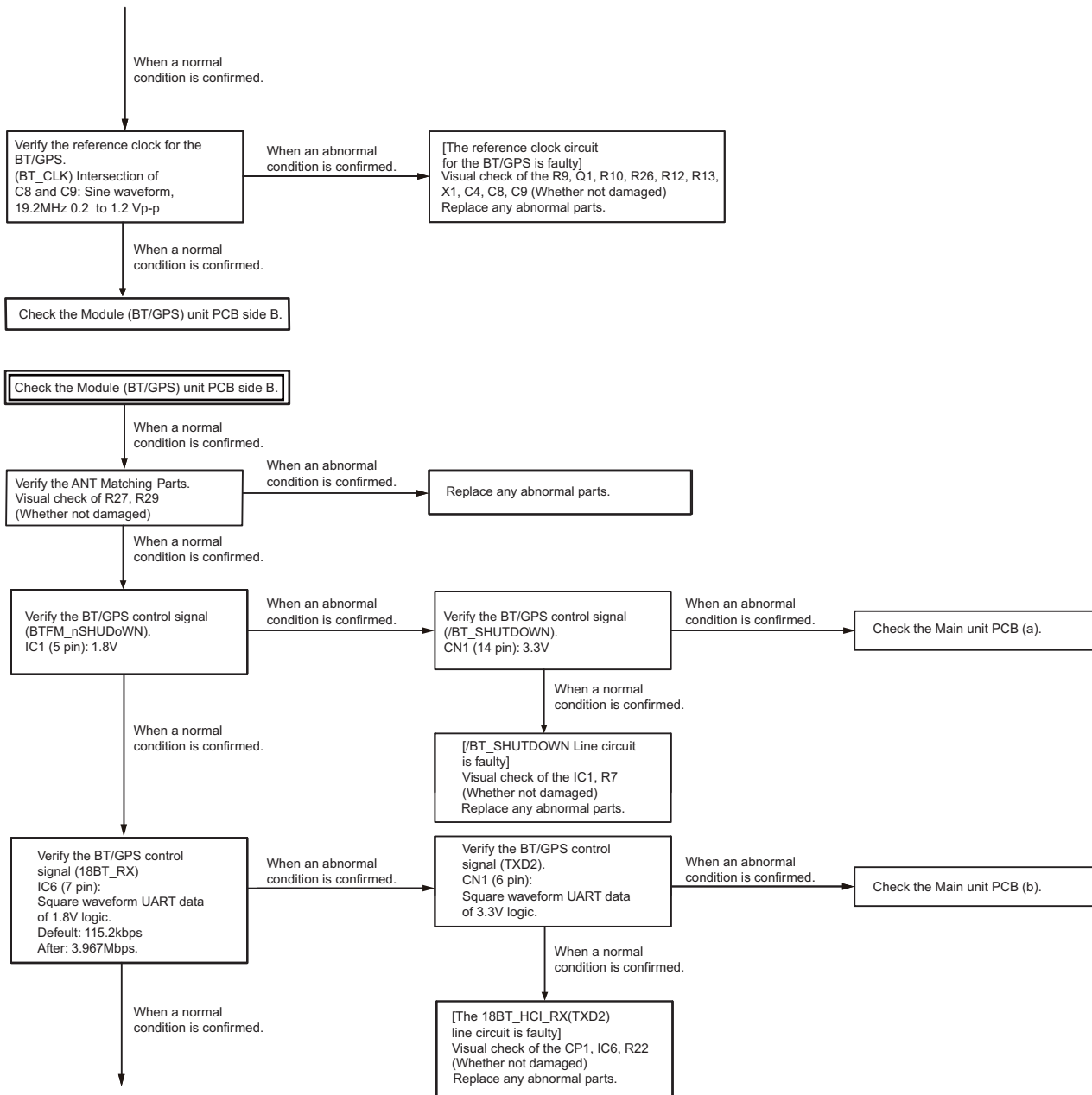

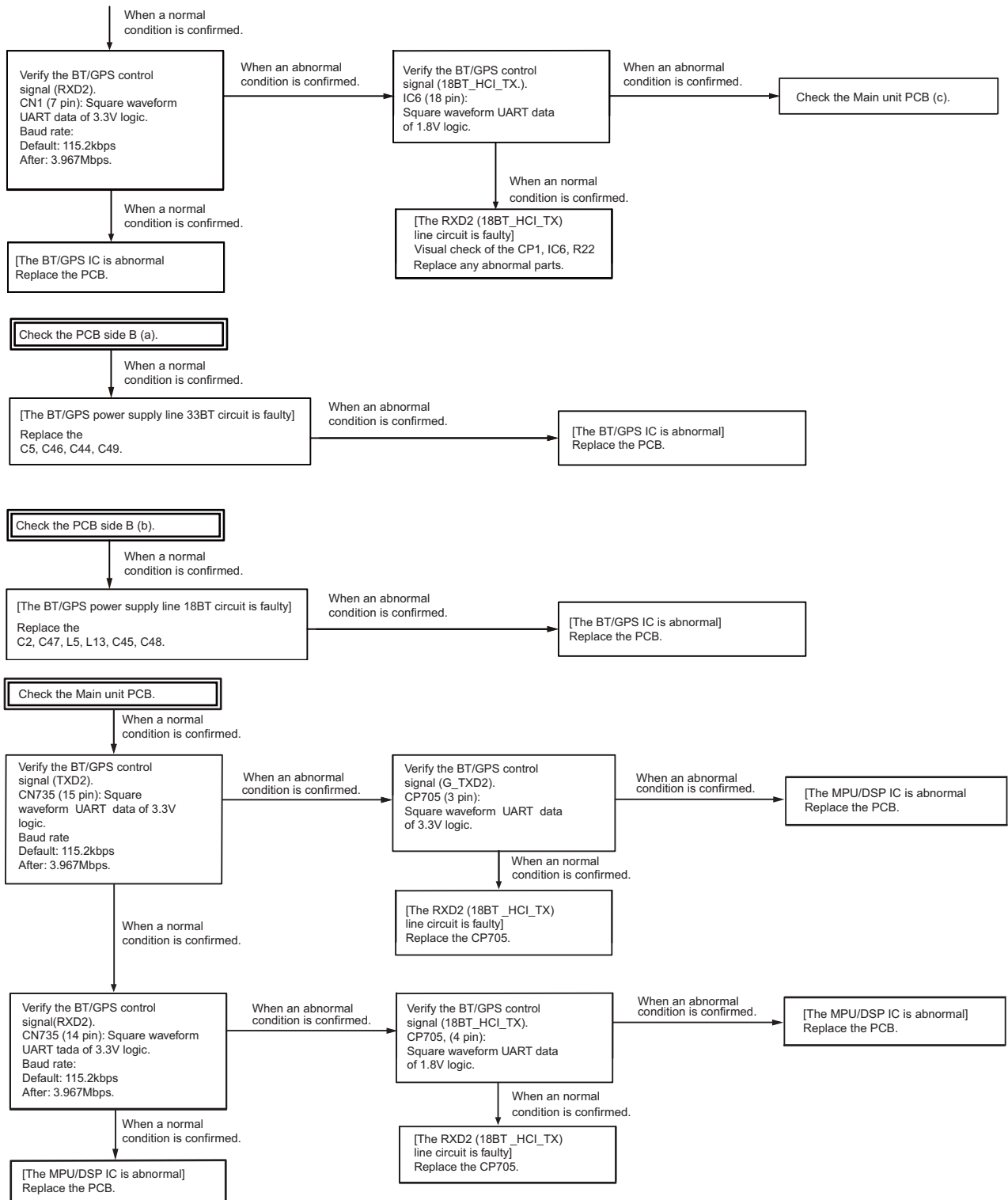

■ Descriptions of signal names

- 1) 33BT: BT/GPS IC 3.3V power supply
- 2) 18BT: BT/GPS IC 1.8V power supply
- 3) TXD2: BT/GPS serial data line connected to UART TX of MPU/DSP IC (MPU/DSP to BT/GPS IC)
- 4) RXD2: BT/GPS serial data line connected to UART RX of MPU/DSP IC (MPU/DSP to BT/GPS IC)
- 5) 18BT_HCI_RX: BT/GPS serial data line connected to UART RX of BT/GPS IC (MPU to BT/GPS IC)
- 6) 18BT_HCI_TX: BT/GPS serial data line connected to UART TX of GPS IC (BT/GPS IC to MPU)
- 7) /BT_SHUTDOWN: BT/GPS active control of MPU/DSP IC (MPU/DSP to BT/GPS IC) High →Active, Low→Reset

5.4 Replacing Main Unit

■Main unit Information

Model Name	Original Main unit Number	For Service Main unit Number
NX-5900 (F,K)	XC1-1021-80	XC1-1021-81

■Method of confirming “Original Main unit” and “Service Main unit”

The 0Ω resistor (R1) is mounted on the “R1” silk print part of the Service Main unit (XC1-1021-81).

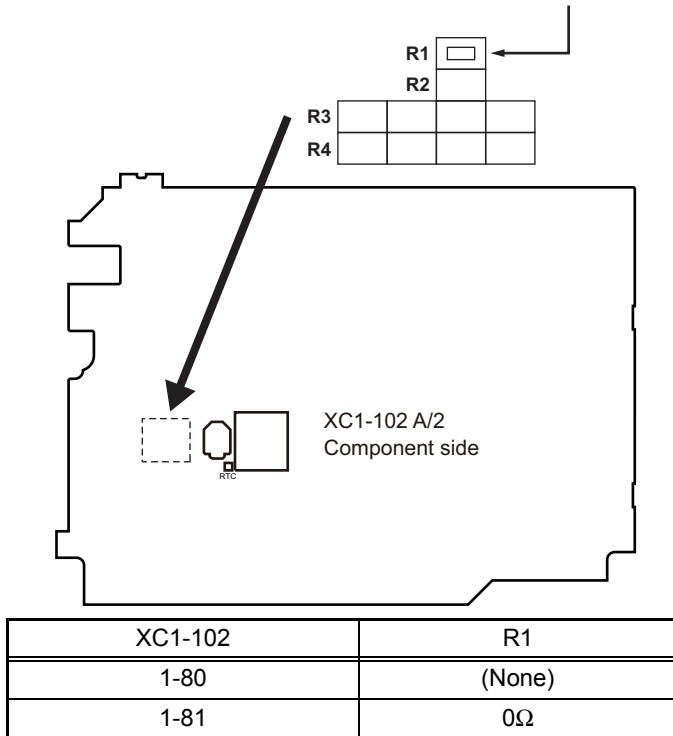

Note:

- The 0Ω resistor (R1) is used to differentiate the destination with a visual check. These are not connected with any PCB pattern; they are specifically for production control. There is no need to change the mount of these resistors.
- There is no difference between the schematic diagram of the Service Main unit (XC1-1021-81) and the schematic diagram of the original Main unit (XC1-1021-80). (R1 is connected with GND (ground) only.)

■Supplied Accessories of “Service Main unit”

Item (Including Parts Number)	Quantity
Main Unit (XC1-102)	1
KENWOOD ESN/ NXDN ESN/ Product Number/ MPT ESN/ P25 ESN Label	1

■Service Main unit” Data

The following data is written on the service unit:

Data Type	Description
Firmware	NX-5900 Firmware.
FPU Data (PC programming mode)	XC1-102 (NX-5900) F type data.
Various Adjustment Data (PC Test mode)	General adjustment values for the XC1-102 (NX-5900) .
KENWOOD ESN	Model name: [XC1-102] NX-5900S Type: F The same number as the KENWOOD ESN label is written.
NXDN ESN/MPT ESN/ Product number/ P25 ESN	The same number as the NXDN ESN/ MPT ESN/Product Number/P25 ESN label is written.

■After Changing the PCB

- After changing the printed circuit board, write the up-to-date Firmware following the instructions in the “2.2 REALIGNMENT - 2.2.6 Firmware Programming Mode”.
 - Write the Firmware in accordance to the Market. If you write different Market Firmware, there are times communication with the FPU is not possible.
- Using the KPG-D1/D1N, select your desired item (Model Name and Frequency) from the Model> Product Information menu, then use Program> Write Data to the Transceiver to write the FPU data (PC Programming mode). When writing to the transceiver, a Warning Message, corresponding to the item selected, appears. Click [OK] to continue writing the data.
- Enter Program> Test Mode, then adjust the various adjustment data (PC Test Mode) as described in the “SECTION 4 ADJUSTMENT”.
- Attach the new labels corresponding to the new printed circuit board. (Refer to the images below for label placement.)
- If necessary, write the FPU data used by the customer with the KPG-D1/D1N.

Note:

- When using the ESN Validation function of NXDN Trunking, the NXDN ESN number changes when the circuit board is changed (the number is written on the circuit board); the NXDN Trunking System cannot be accessed. Use the KPG-110SM on the NXDN Trunking System side to reprogram the NXDN ESN number.

- When a new printed circuit board is used, the KENWOOD ESN changes, as does the Transceiver Information display of the KPG-D1/D1N, but this does not have any effect on the operation of the transceiver.
- If changing to the original ESN, please contact our service center.

■ESN Label Layout

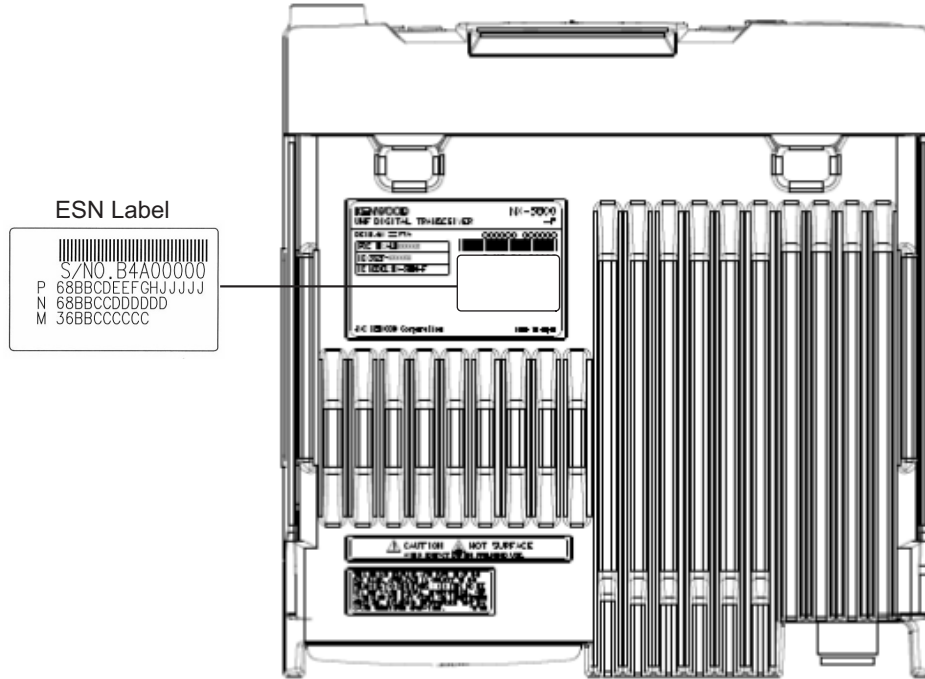

5.5 Failure diagnosis of the Transmitter section

Overview:

When the Transmitter section does not operate, use this flowchart to determine the problem.

Confirmation before this failure diagnosis:

Before attempting to diagnose the transmitter section, check the calibration of measurement equipments (i.e.power meter). Whenever the transmitter is turn on, the unit must be mounted on the chassis and connected to a suitable dummy load.

Major parts of the Transmitter section

- Final FET (Q303)
- Drive FET (Q302)
- Power Control IC (IC302)
- ANT Switch Diode (D305, D306, D308)
- 90C AVR (IC15)
- 50CT AVR (IC16)
- Fuse (F300)

Note:

The Final FET is not able to be replaced using the service equipment, the Final FET is not registered as a service part. Therefore, the Main unit must be replaced by the Service Main unit when the Final FET is defective. This Failure diagnosis of Transmitter section is created to judge a defective Final FET.

Test Channel for the voltage verification

Test Channel 1-1 (TX frequency: 793.05MHz)_HighPower

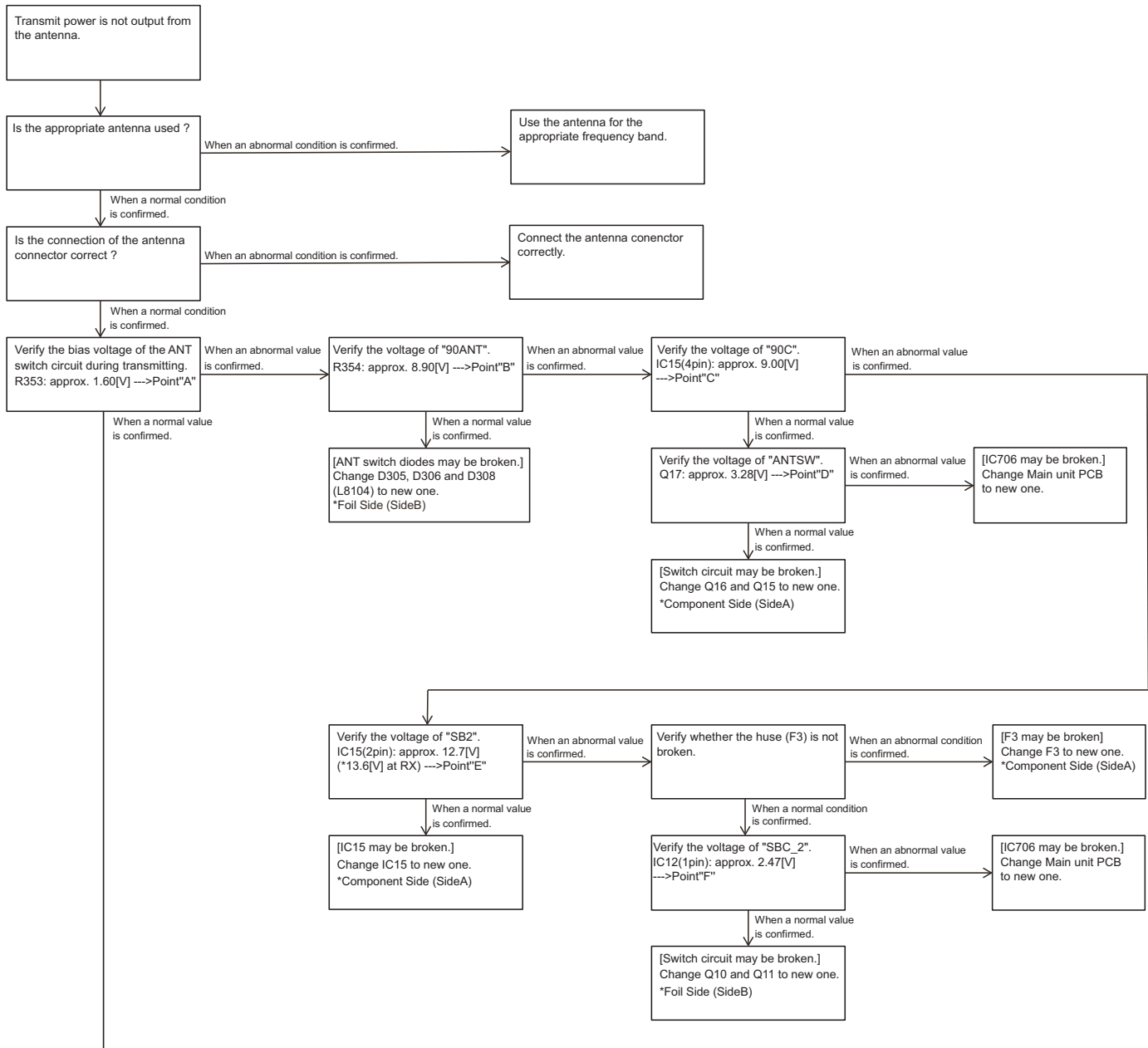

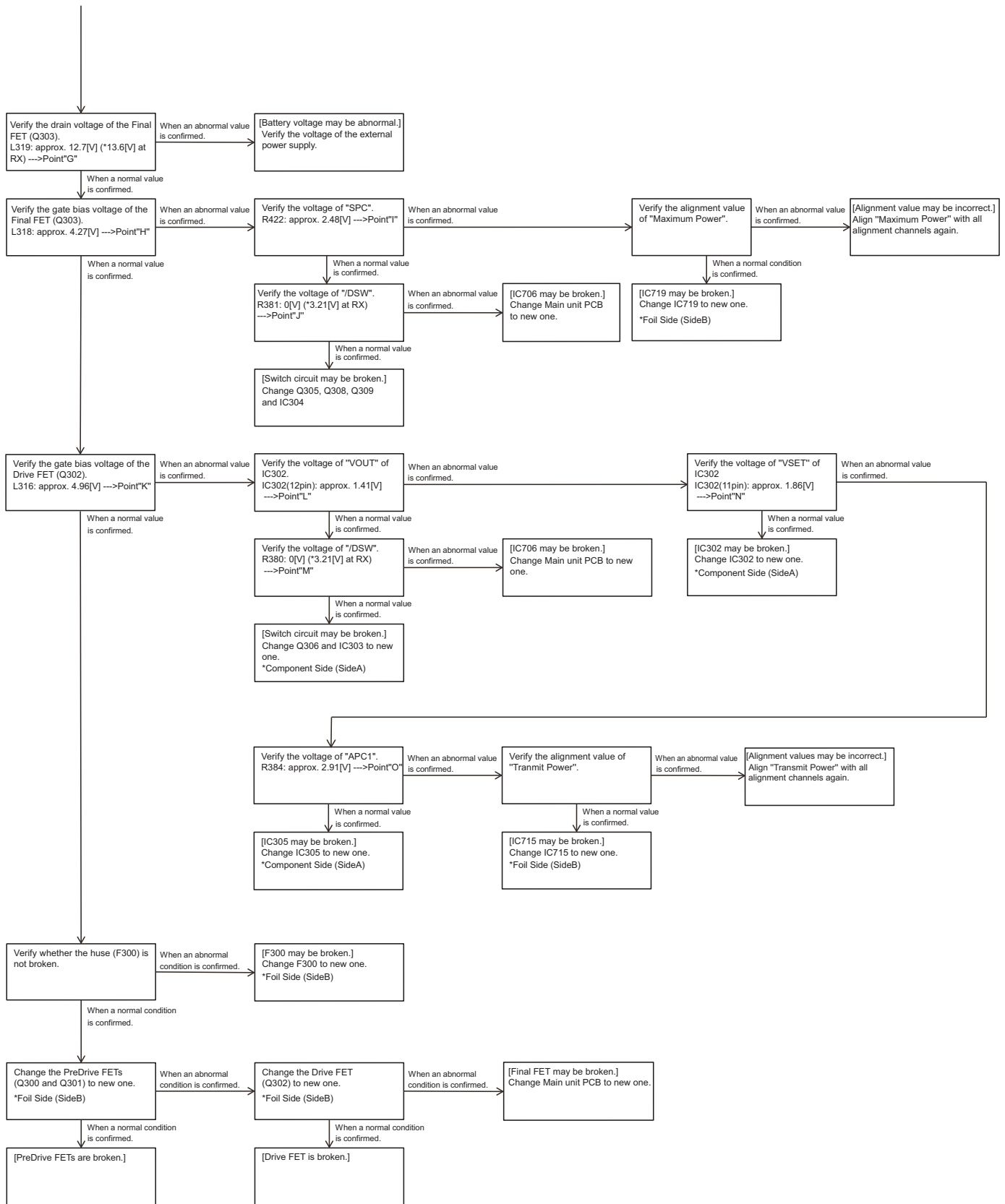

Voltage check point

Main unit PCB Component Side (SideA)

■Point A, B, D, L, N

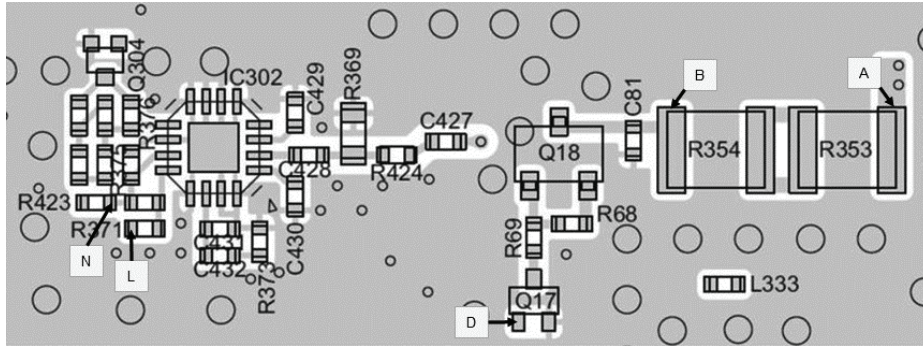

■Point C, E

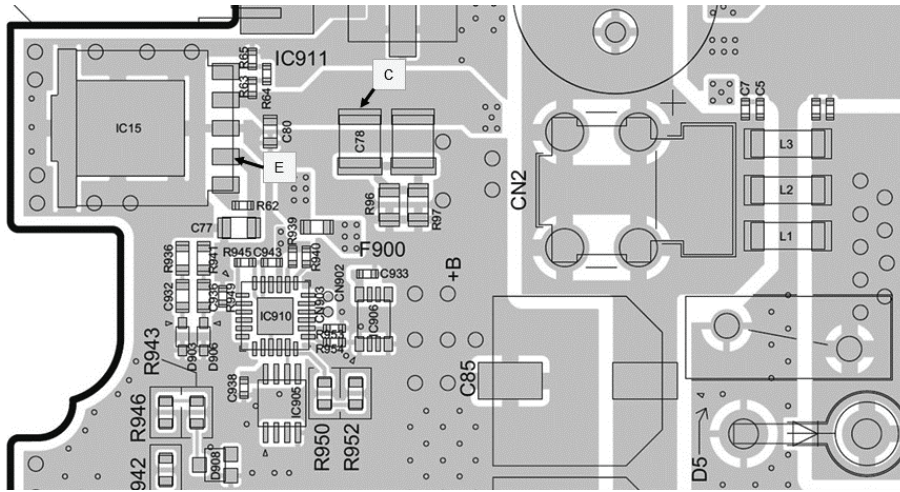

■Point F

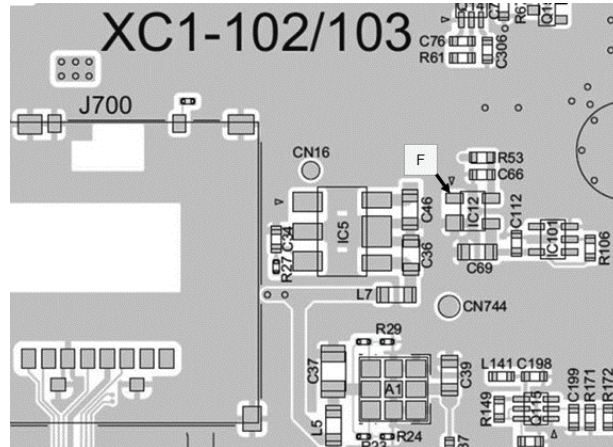

■Point G

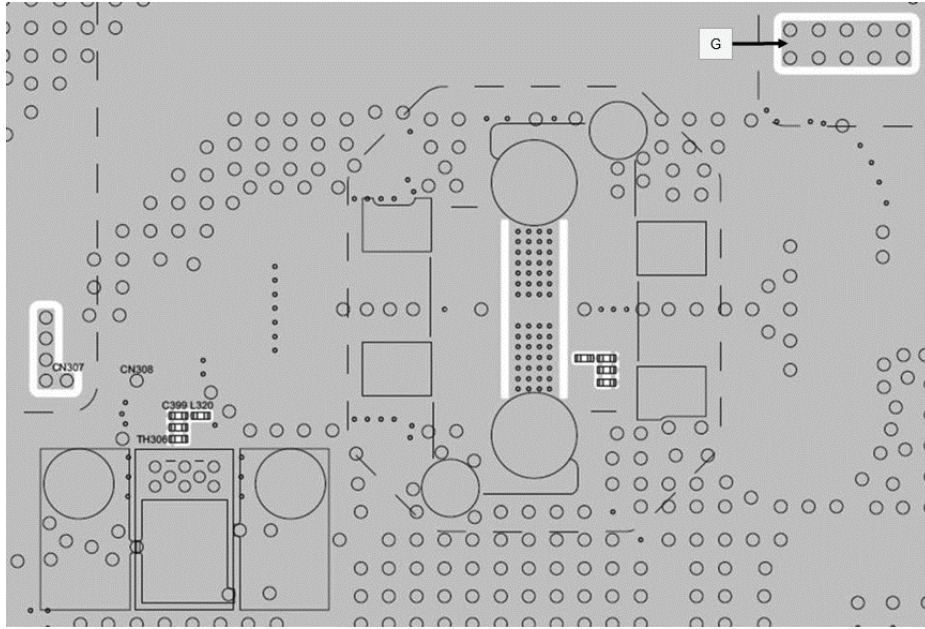

■Point H, I, J, K, M, O

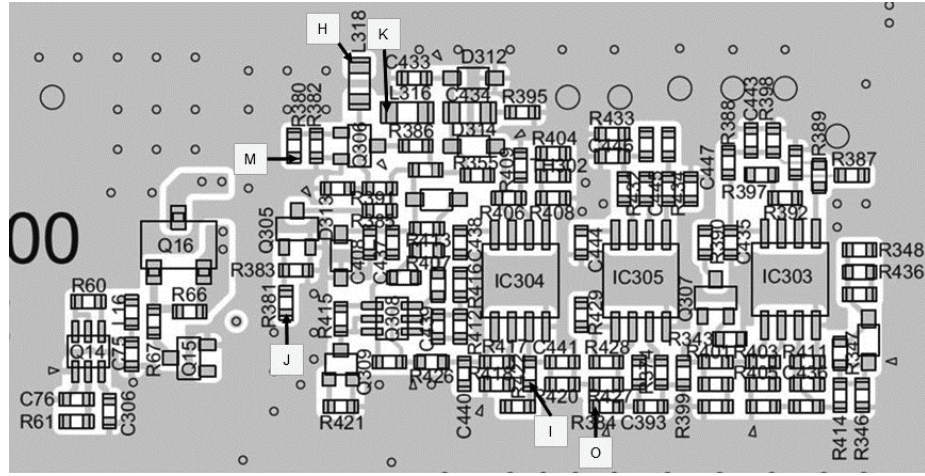

MEMO

SCHEMATIC DIAGRAM

■ MAIN UNIT (XC1-1021-80, NX-5900(K), NX-5900(F), NX-5900(B)(K))

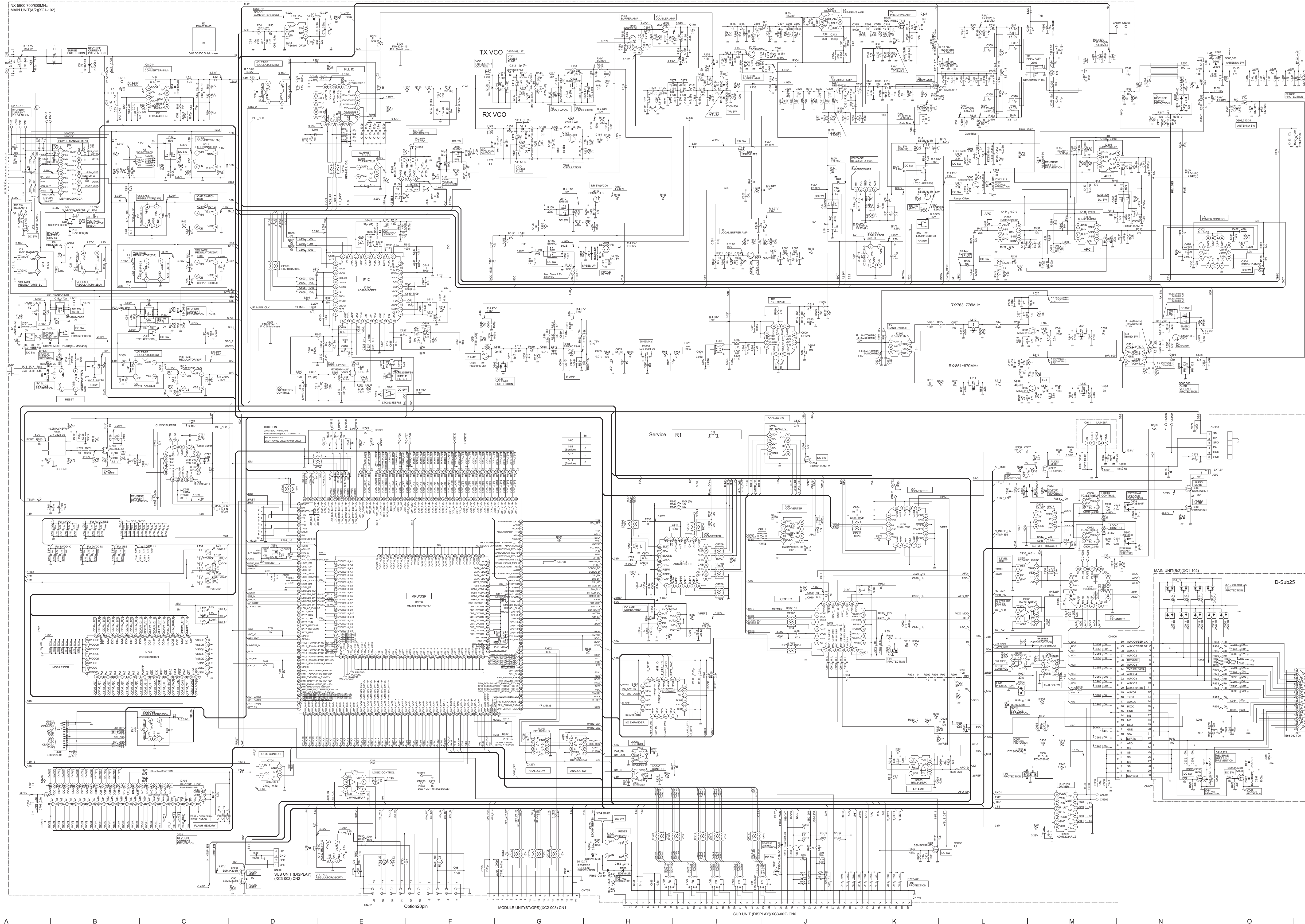

BLOCK DIAGRAM
MAIN UNIT

10
9
8
7
6
5
4
3
2
1

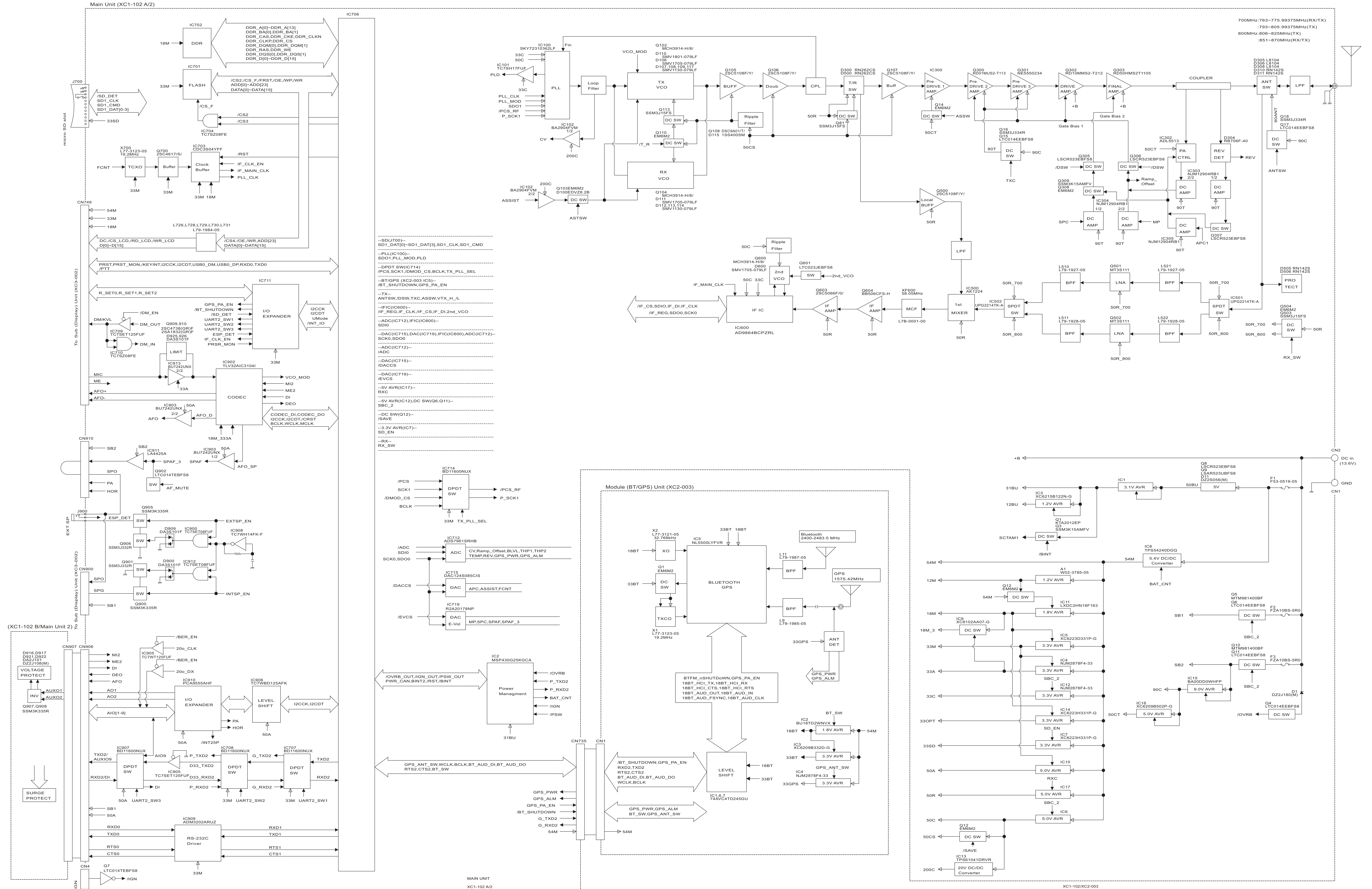

■ SUB (Display) UNIT

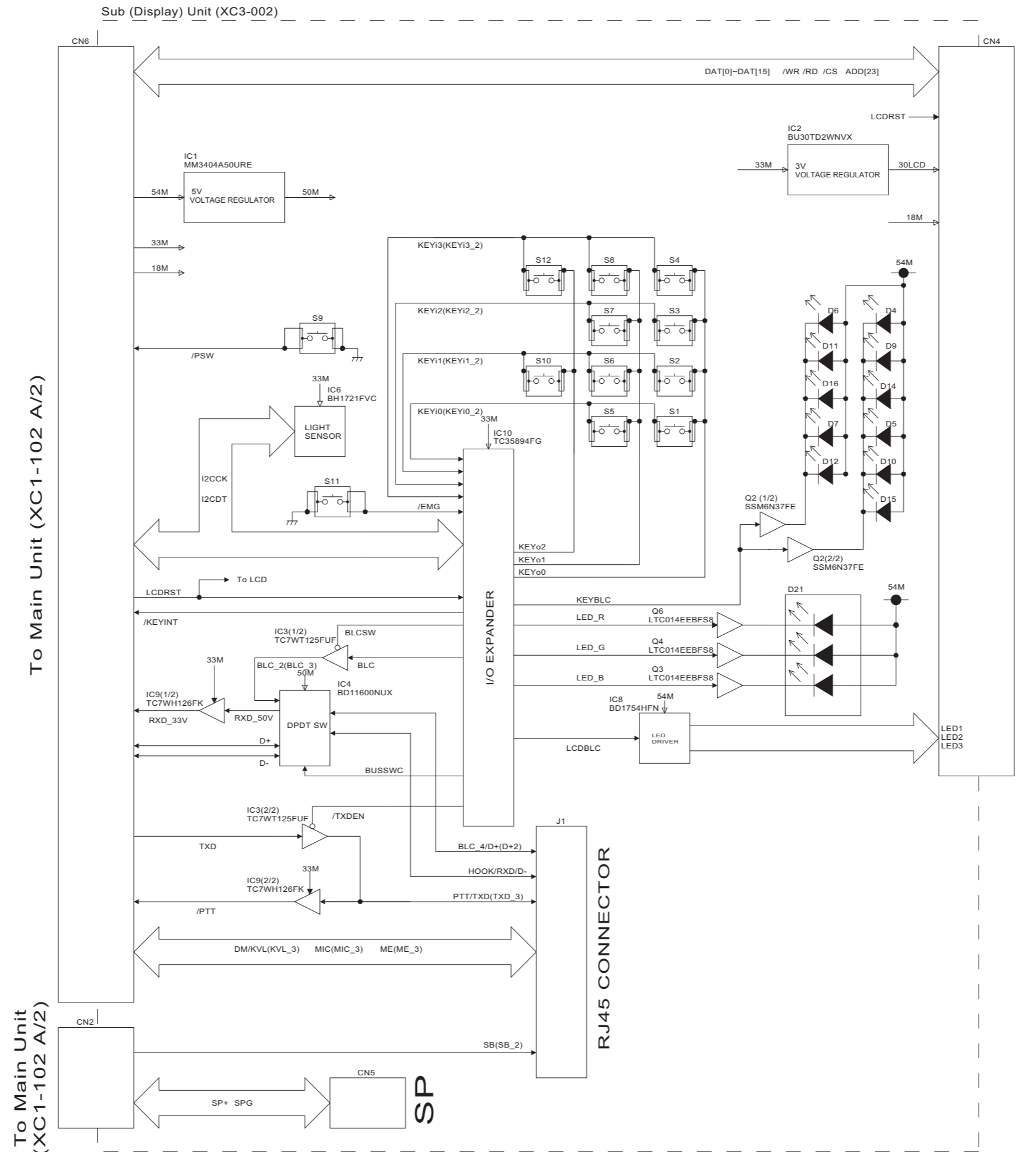

PRINTED CIRCUIT BOARD

■ MAIN UNIT (XC1-1021-80) (XC1-1021-80 (NX-5900(K), NX-5900B(F), NX-5900B(K)))

--- Component side view (J7C-0126-00) ---

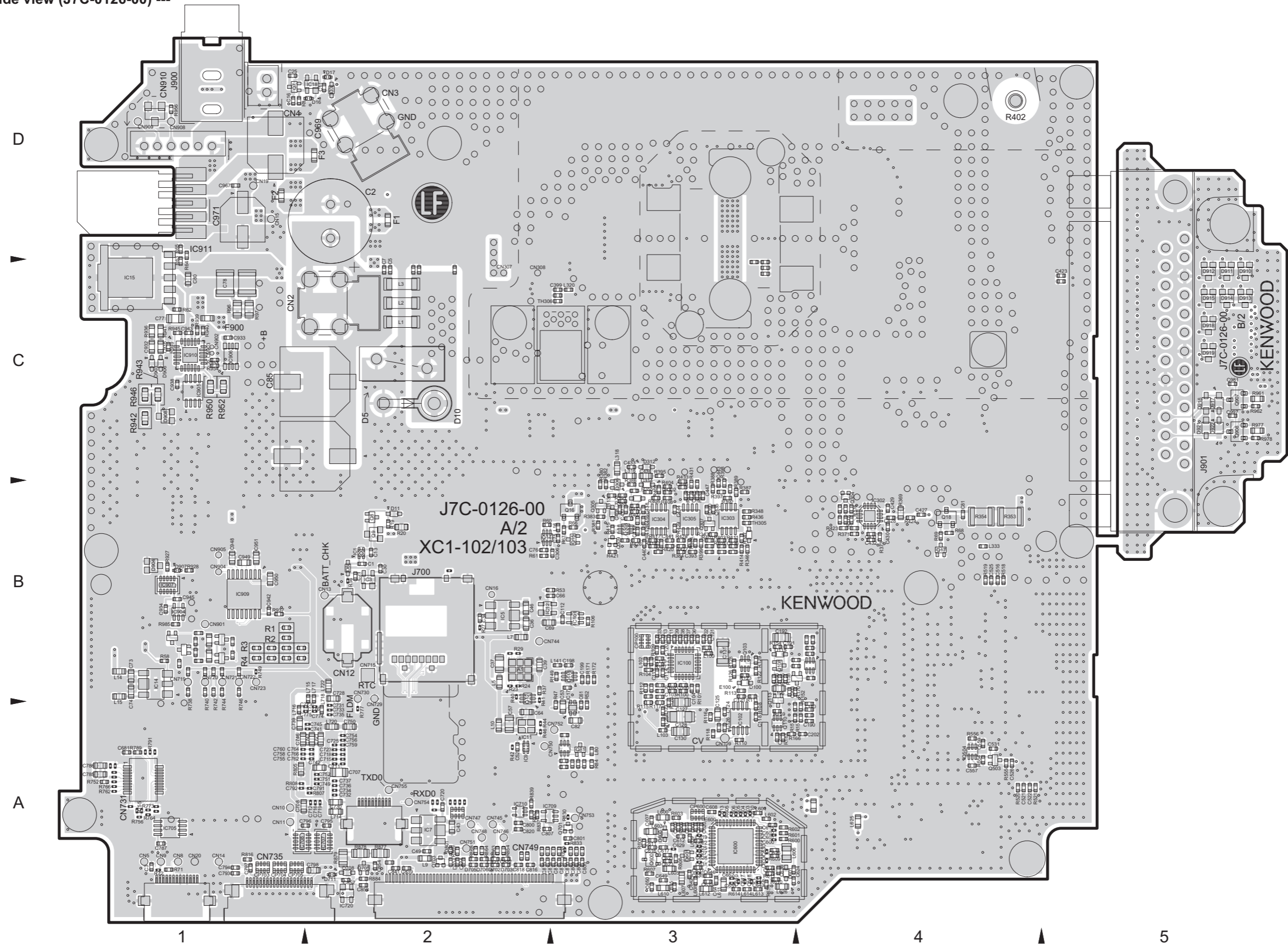

■ MAIN UNIT (XC1-1021-80) (XC1-1021-80 (NX-5900(K), NX-5900B(F), NX-5900B(K)))

--- Foil side view (J7C-0126-00) ---

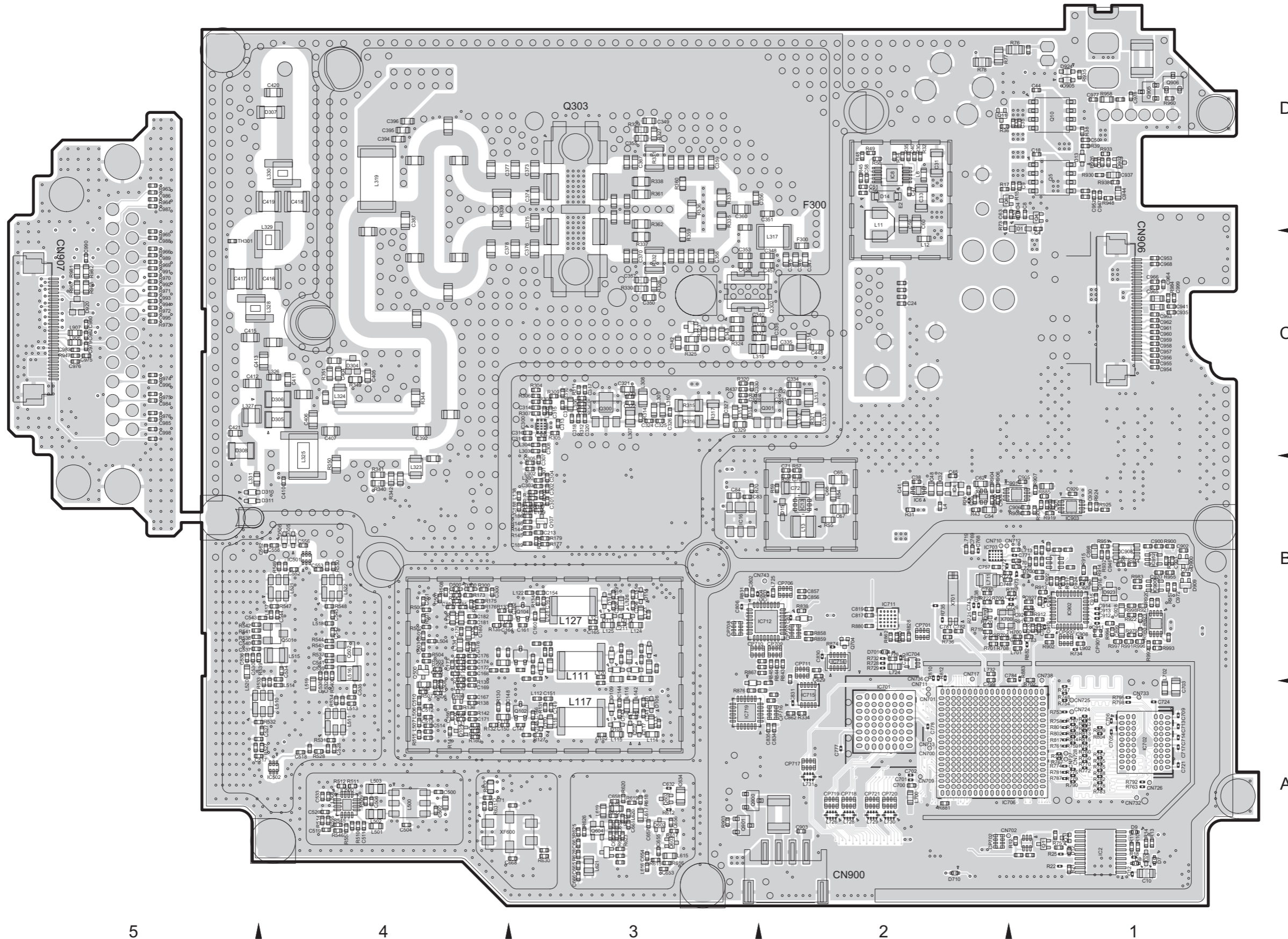

5

4

3

2

1

D

▲

C

▲

B

▲

A

■ MODULE (BT/GPS) UNIT (XC2-0031-80)

--- Component side view (J7C-0037-00) ---

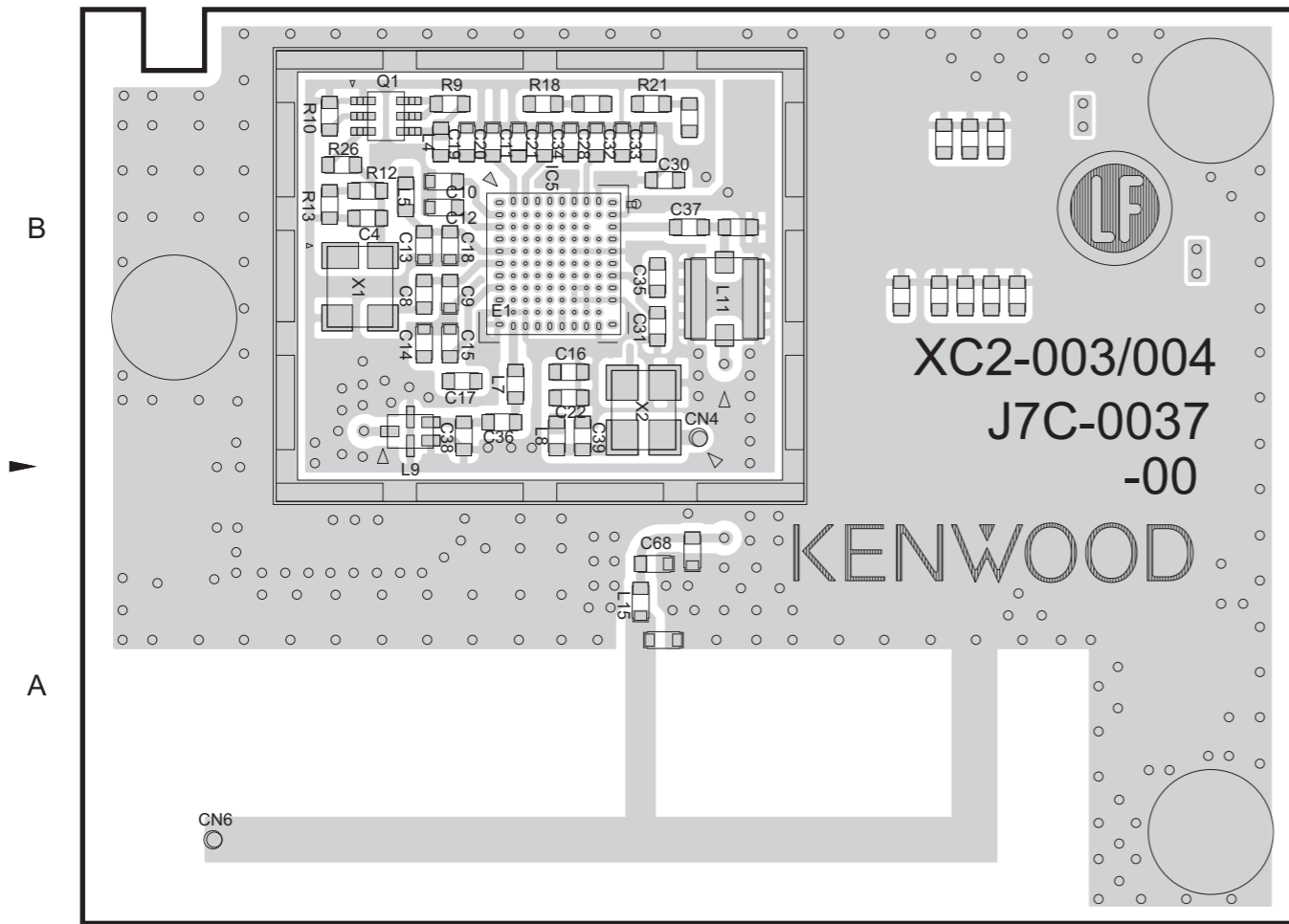

--- Foil side view (J7C-0037-00) ---

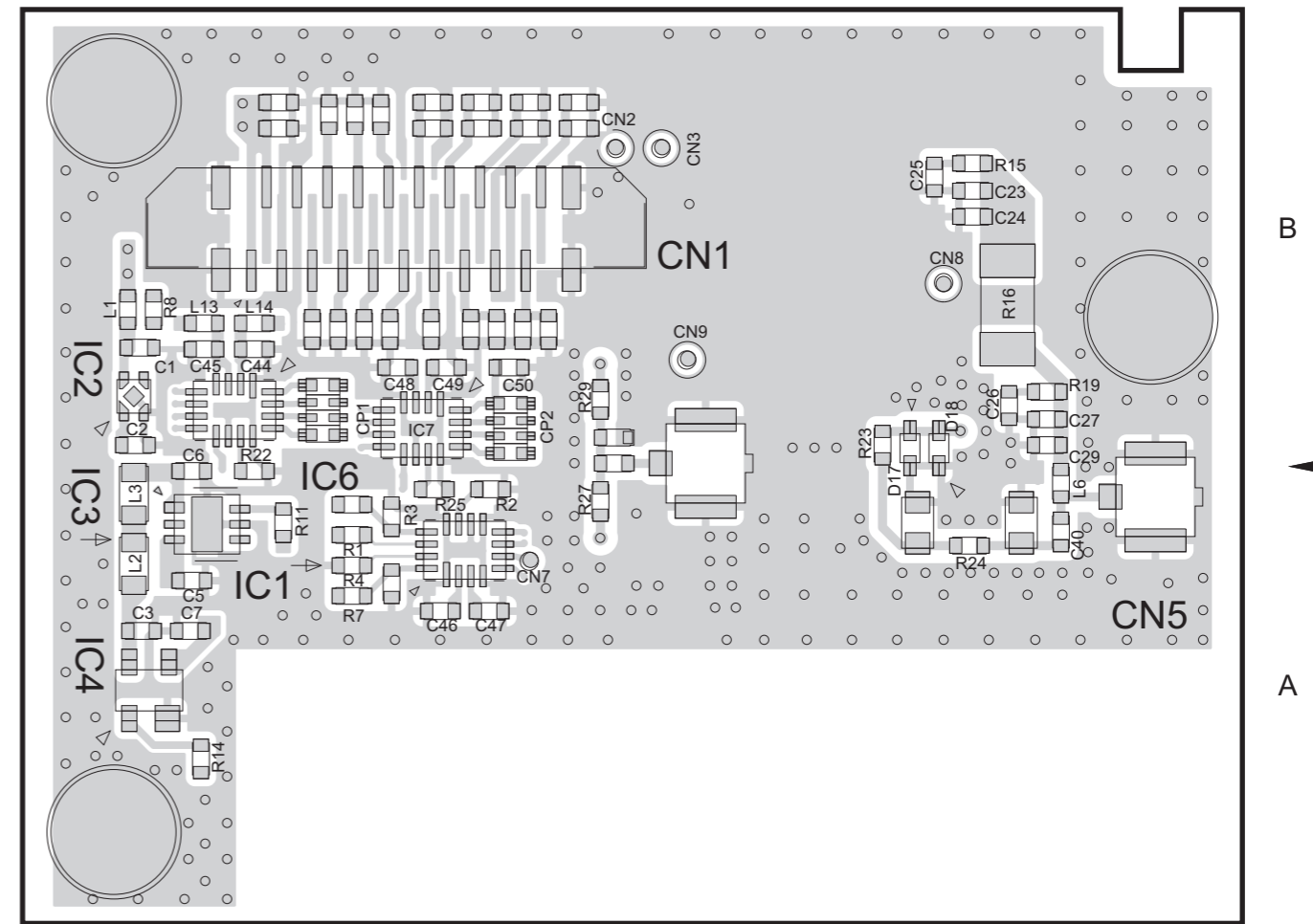

● ADDRESS TABLE OF BOARD PARTS

Each address may have an address error by one interval.



REF.NO.	LOCATION	REF.NO.	LOCATION	REF.NO.	LOCATION	REF.NO.	LOCATION	REF.NO.	LOCATION	REF.NO.	LOCATION
IC		R7	B-3A	CAPACITOR	C21	A-2B	C45	B-3B			
IC1	B-2A	R8	B-3B	C1	B-3B	C22	A-2B	C46	B-2A	CP1	B-3B
IC2	B-3B	R9	A-1B	C2	B-3B	C23	B-1B	C47	B-2A	CP2	B-2B
IC3	B-3A	R10	A-1B	C3	B-3A	C24	B-1B	C48	B-3B		
IC4	B-3A	R11	B-3A	C4	A-1B	C25	B-1B	C49	B-2B	E1	A-2B
IC5	A-2B	R12	A-1B	C5	B-3A	C26	B-1B	C50	B-2B		
IC6	B-3B	R13	A-1B	C6	B-3A	C27	B-1B	C68	A-2A	L1	B-3B
IC7	B-3B	R14	B-3A	C7	B-3A	C28	A-2B			L2	B-3A
		R15	B-1B	C8	A-1B	C29	B-1B			L3	B-3A
TRANSISTOR		R16	B-1B	C9	A-1B	C30	A-2B	X1	A-1B	L4	A-1B
Q1	A-1B	R18	A-2B	C10	A-1B	C31	A-2B	X2	A-2B	L5	A-1B
		R19	B-1B	C11	A-2B	C32	A-2B			L6	B-1A
DIODE		R21	A-2B	C12	A-1B	C33	A-2B	CN1	B-3B	L7	A-2B
D17	B-1B	R22	B-3A	C13	A-1B	C34	A-2B	CN2	B-2B	L8	A-2B
D18	B-1B	R23	B-1B	C14	A-1B	C35	A-2B	CN3	B-2B	L9	A-1B
		R24	B-1A	C15	A-1B	C36	A-2B	CN4	A-2B	L11	A-2B
RESISTOR		R25	B-2A	C16	A-2B	C37	A-2B	CN5	B-1A	L13	B-3B
R1	B-3A	R26	A-1B	C17	A-1B	C38	A-1B	CN6	A-1A	L14	B-3B
R2	B-2A	R27	B-2A	C18	A-1B	C39	A-2B	CN7	B-2A	L15	A-2A
R3	B-3A	R29	B-2B	C19	A-1B	C40	B-1A	CN8	B-1B		
R4	B-3A			C20	A-2B	C44	B-3B	CN9	B-2B		

■ SUB (DISPLAY) UNIT (XC3-0020-20 (NX-5900(K)))

--- Component side view (J7C-0038-00) ---

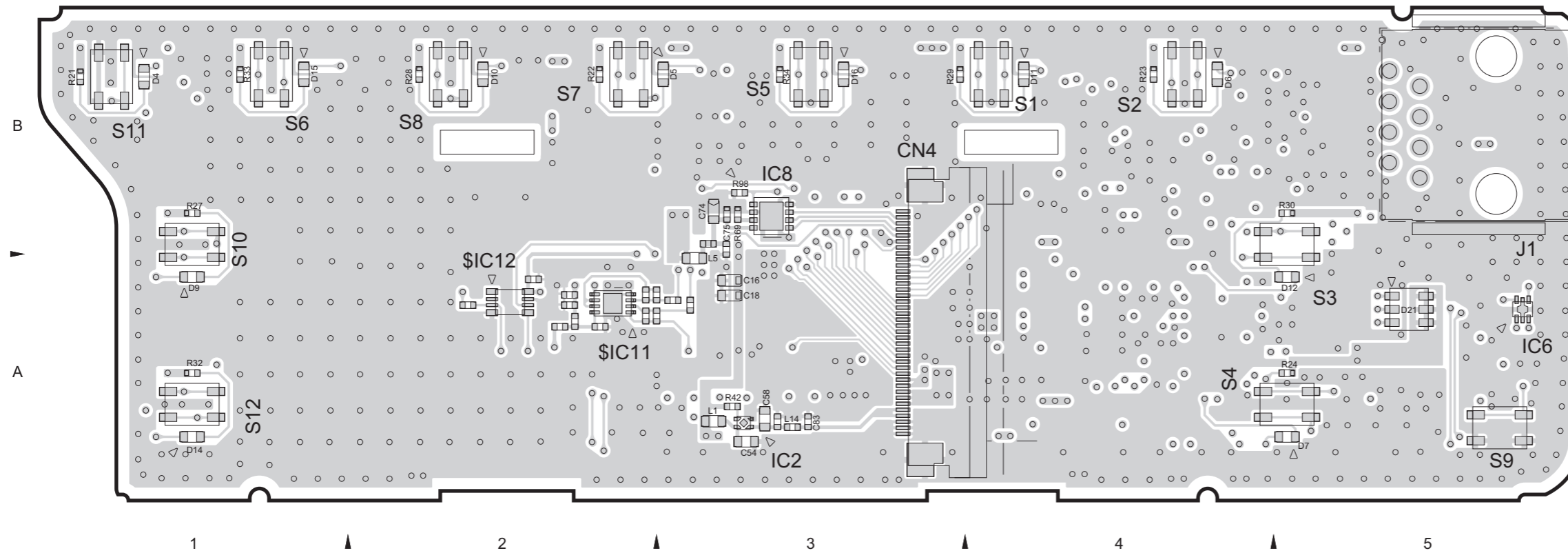

--- Foil side view (J7C-0038-00) ---

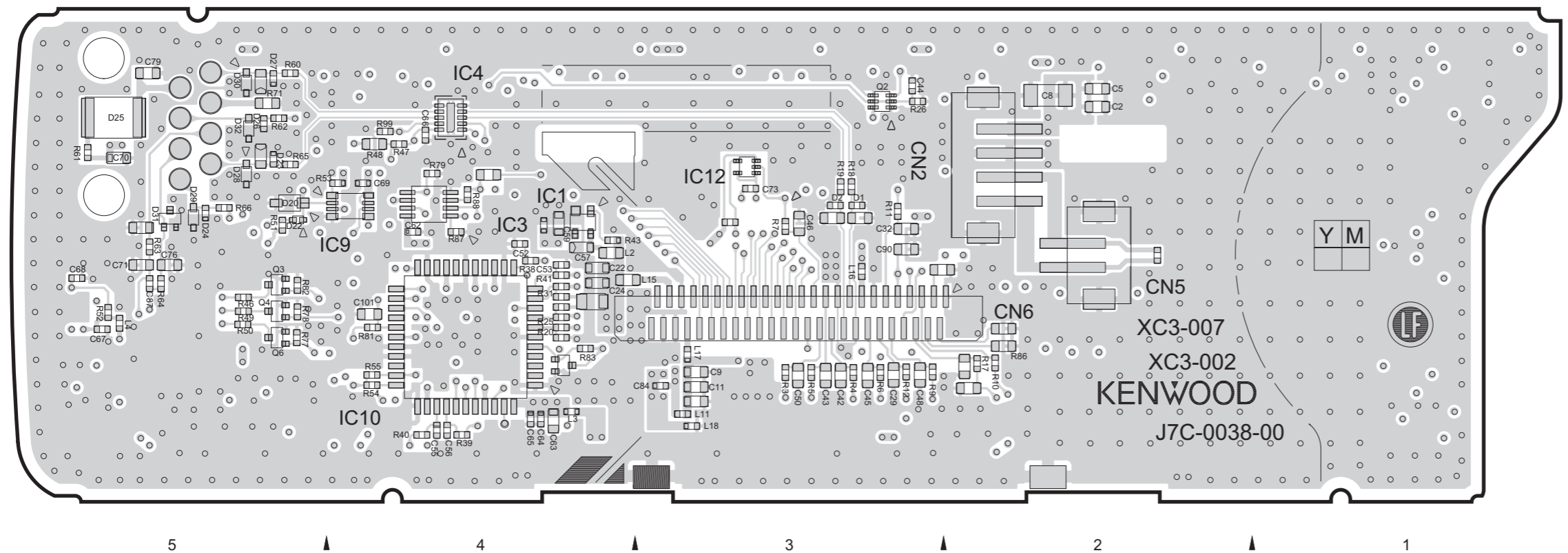

● ADDRESS TABLE OF BOARD PARTS

Each address may have an address error by one interval.



REF.NO.	LOCATION	REF.NO.	LOCATION	REF.NO.	LOCATION
IC		R52	B-5A	S7	A-2B
IC1	B-4B	R53	B-4B	S8	A-2B
IC2	A-3A	R54	B-4A	S9	A-5A
IC3	B-4B	R55	B-4A	S10	A-1B
IC4	B-4B	R60	B-5B	S11	A-1B
IC6	A-5A	R61	B-5B	S12	A-1A
IC8	A-3B	R62	B-5B		
IC9	B-4B	R63	B-5B	J1	A-5B
IC10	B-4A	R64	B-5A		
IC12	B-3B	R65	B-5B	L1	A-3A
		R66	B-5B	L2	B-4B
TRANSISTOR					
		R69	A-3B	L3	B-4A
		R71	B-5B	L4	B-5A
Q2	B-3B	R77	B-5A	L5	A-3A
Q3	B-5A	R78	B-5A	L11	B-3A
Q4	B-5A	R79	B-4B	L14	A-3A
Q6	B-5A	R81	B-4A	L15	B-4A
		R82	B-5A	L16	B-3A
		R83	B-4A	L17	B-3A
DIODE					
D1	B-3B	R86	B-2A	L18	B-3A
D2	B-3B	R87	B-4B		
D4	A-1B	R88	B-4B		
D5	A-3B	R98	A-3B		
D6	A-4B	R99	B-4B		
D7	A-5A				
D9	A-1A	CAPACITOR			
D10	A-2B	C2	B-2B		
D11	A-4B	C5	B-2B		
D12	A-5A	C8	B-2B		
D14	A-1A	C9	B-3A		
D15	A-1B	C11	B-3A		
D16	A-3B	C16	A-3A		
D20	B-5B	C18	A-3A		
D21	A-5A	C18	A-3A		
D22	B-5B	C22	B-4A		
D23	B-5B	C24	B-4A		
D24	B-5B	C29	B-3A		
D25	B-5B	C32	B-3B		
D26	B-5B	C42	B-3A		
D27	B-5B	C43	B-3A		
D28	B-5B	C44	B-3B		
D29	B-5B	C45	B-3A		
D30	B-5B	C46	B-3B		
D31	B-5B	C48	B-3A		
D32	B-5B	C50	B-3A		
		C52	B-4B		
		C53	B-4A		
RESISTOR					
R3	B-3A	C54	A-3A		
R4	B-3A	C55	B-4A		
R5	B-3A	C56	B-4A		
R6	B-3A	C57	B-4B		
R7	B-3B	C58	A-3A		
R9	B-3A	C59	B-4B		
R10	B-2A	C62	B-4B		
R11	B-3B	C63	B-4A		
R12	B-3A	C64	B-4A		
R17	B-2A	C65	B-4A		
R18	B-3B	C66	B-4B		
R19	B-3B	C67	B-5A		
R20	B-4A	C68	B-5A		
R21	A-1B	C69	B-4B		
R22	A-2B	C70	B-5B		
R23	A-4B	C71	B-5A		
R24	A-5A	C73	B-3B		
R25	B-4A	C74	A-3B		
R26	B-3B	C75	A-3B		
R27	A-1B	C76	B-5A		
R28	A-2B	C79	B-5B		
R29	A-3B	C83	A-3A		
R30	A-5B	C84	B-3A		
R31	B-4A	C87	B-5A		
R32	A-1A	C90	B-3B		
R33	A-1B	C101	B-4A		
R34	A-3B				
R38	B-4A	OTHER			
R39	B-4A	CN2	B-2B		
R40	B-4A	CN4	A-3A		
R41	B-4A	CN5	B-2B		
R42	A-3A	CN6	B-3A		
R43	B-4B				
R46	B-5A	S1	A-4B		
R47	B-4B	S2	A-4B		
R48	B-4B	S3	A-5B		
R49	B-5A	S4	A-5A		
R50	B-5A	S5	A-3B		
R51	B-5B	S6	A-1B		

MODULE (BT/GPS) UNIT (XC2-0031-80)

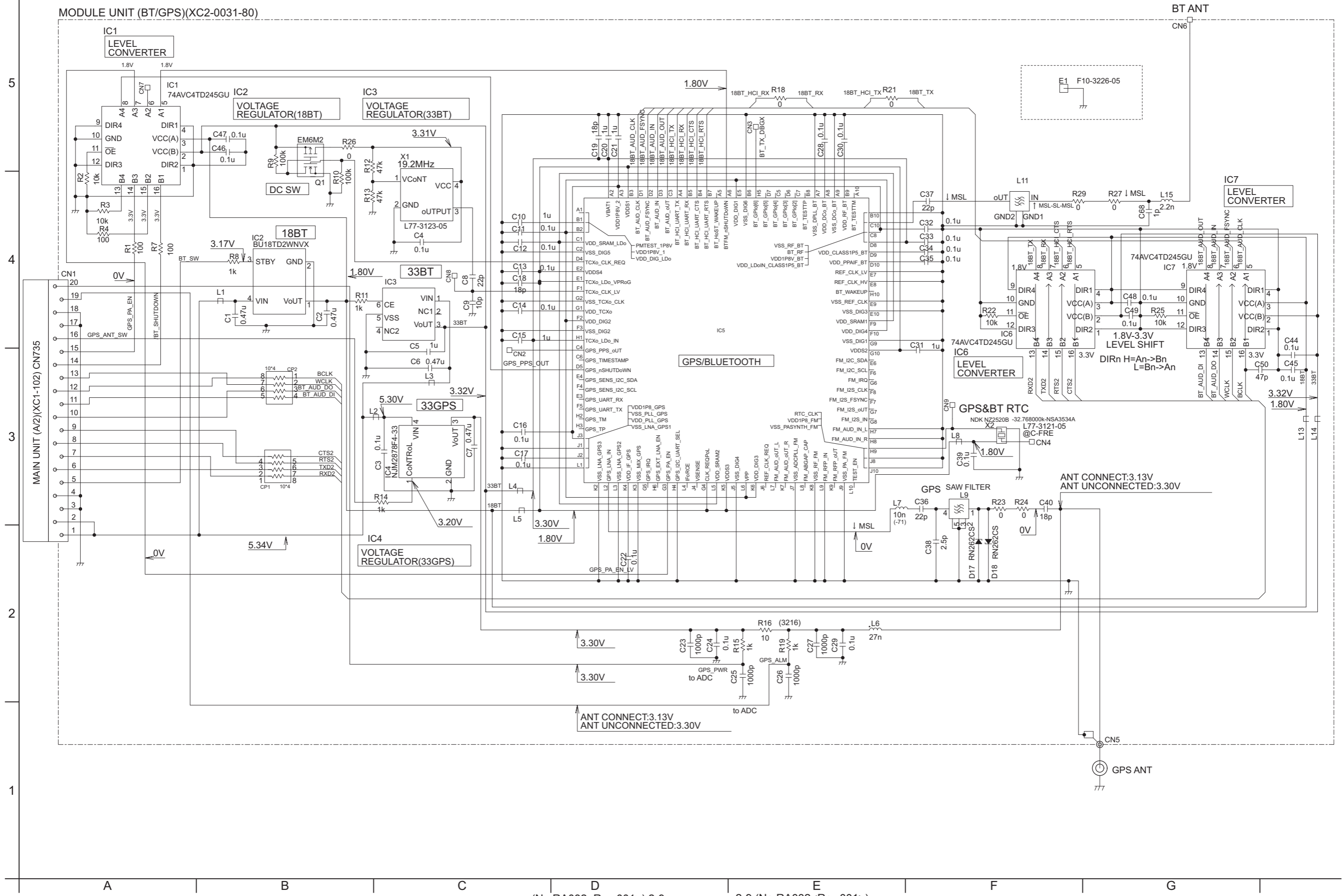

■ SUB (DISPLAY) UNIT (XC3-0020-20 (NX-5900(K)))

SUB UNIT (DISPLAY)(XC3-002)

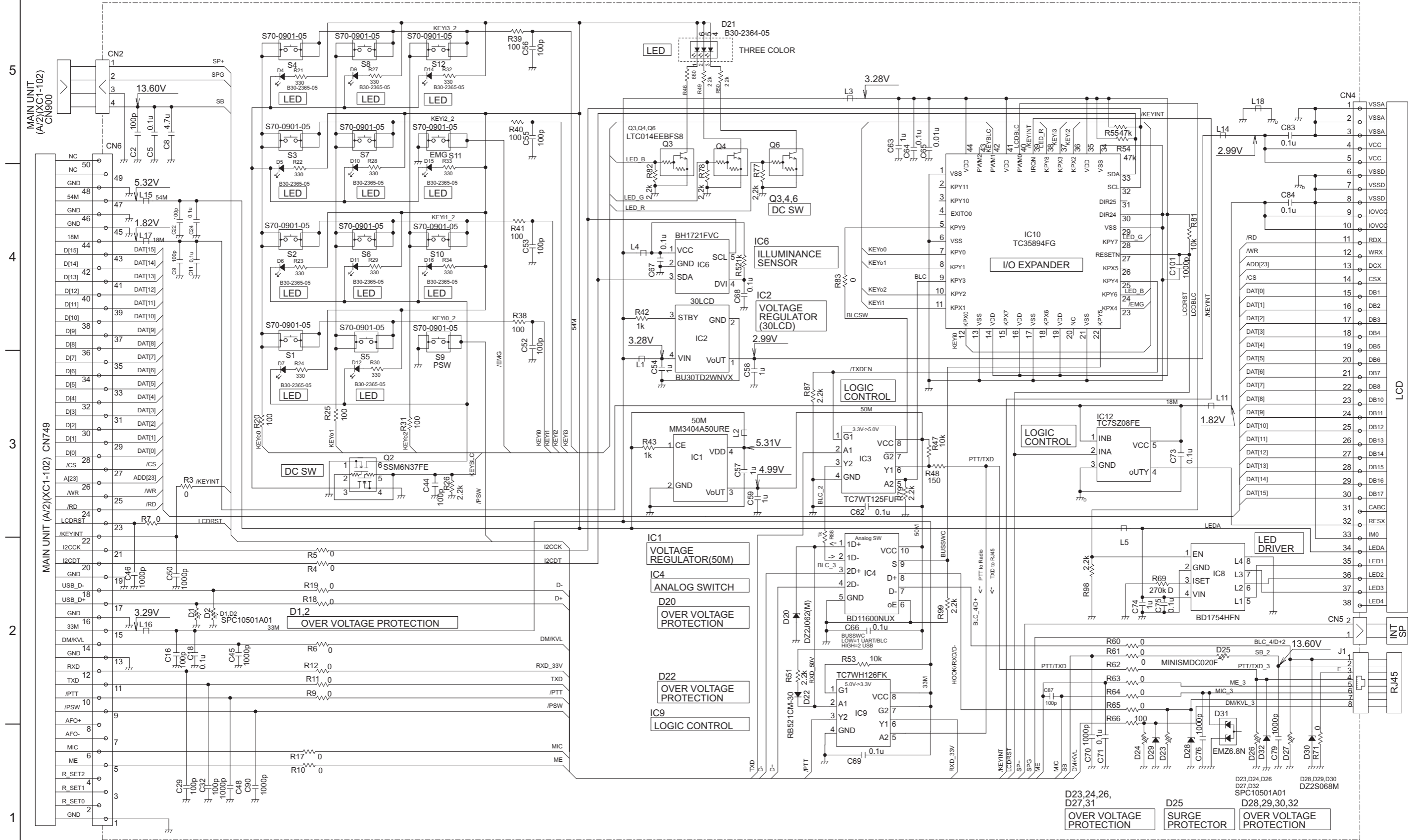

LEVEL DIAGRAM

Receiver Section

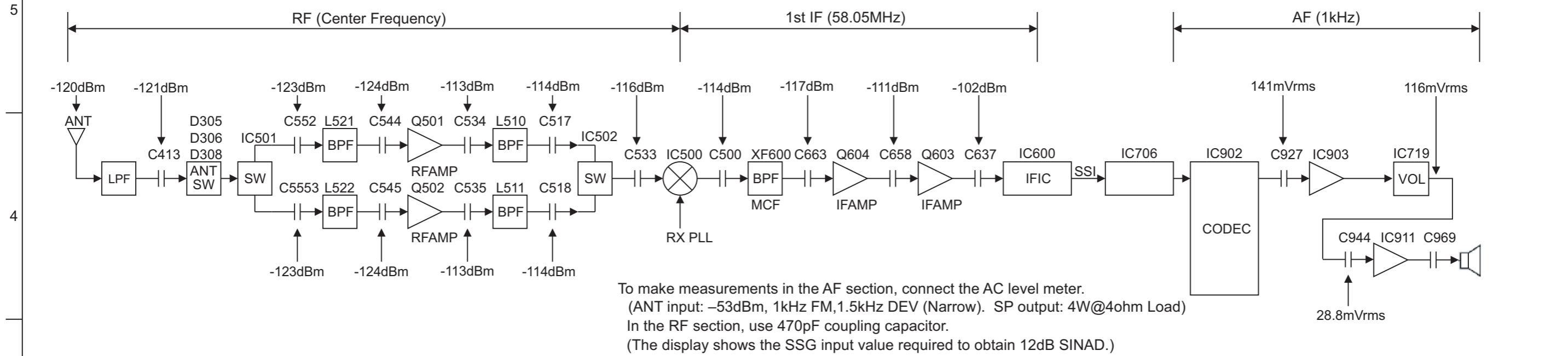

Transmitter Section

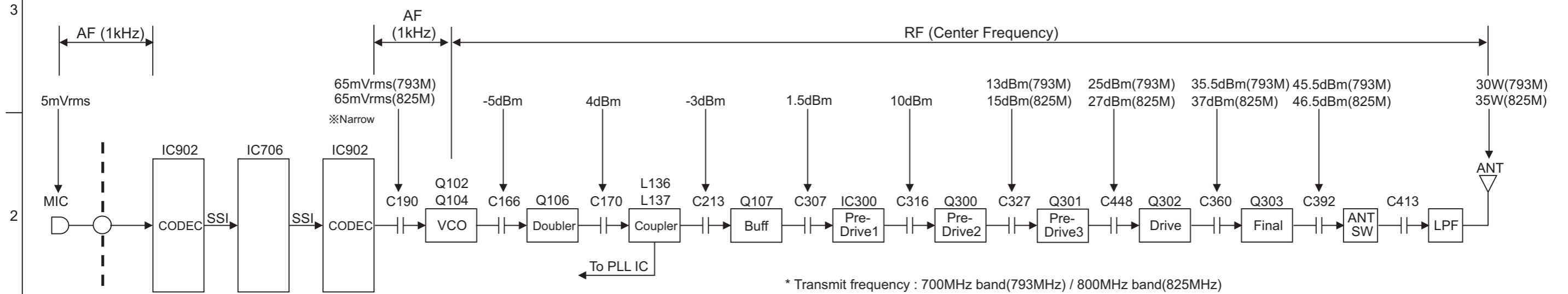

PARTS LIST

[NX-5900,NX-5900(B)]

* SAFETY PRECAUTION

Parts identified by the \triangle symbol are critical for safety. Replace only with specified part numbers.

* BEWARE OF BOGUS PARTS

Parts that do not meet specifications may cause trouble in regard to safety and performance. We recommend that genuine parts be used.

* (x_) in a description column shows the number of the used part.

- Contents -

Exploded view of general assembly and parts list	3-2
Electrical parts list	3-4
Packing materials and accessories parts list	3-17

Exploded view of general assembly and parts list

Block No.M1MM

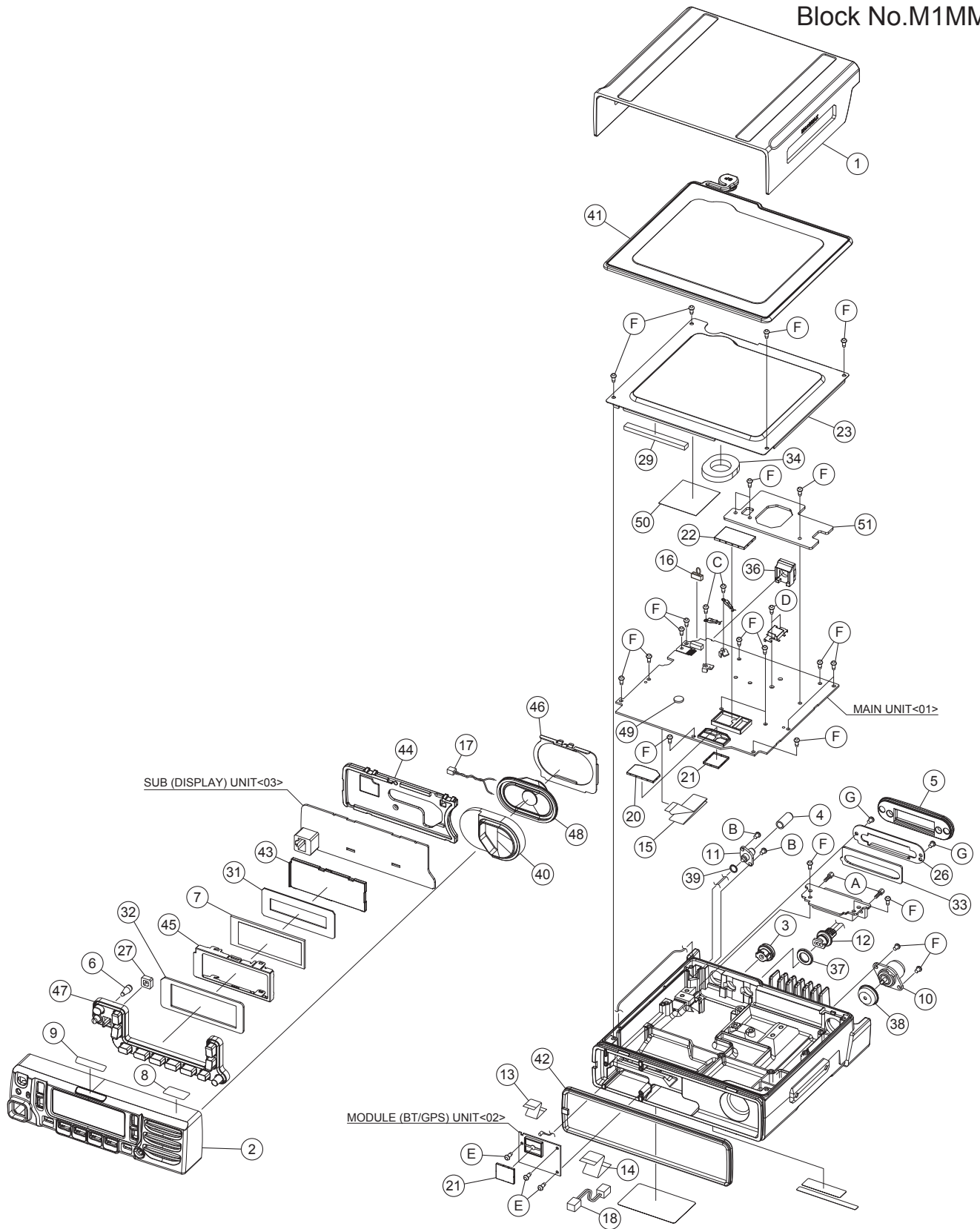

General assembly

Block No. [M][1][M][M]

△ Symbol No.	Part No.	Part Name	Description	Local
1	A0C-0107-00	PLASTIC CABINET		
2	A6C-0003-20	PANEL ASSY		5900_K
3	B09-0681-03	CAP(KAP-2)		
4	B09-0754-05	CAP(SMA)		
5	B0K-0004-00	CAP(D-SUB)		
6	B1B-0017-00	ILLUMINATION GUIDE		5900_K
7	B38-0966-05	LCD ASSY		5900_K
8	B4B-0008-00	CAUTION STICKER		5900_K
9	B4D-0021-00	BADGE		5900_K
10	E04-0170-35	RF COAXIAL RECEPTACLE-N (ANT)		
11	E0E-0021-00	RF COAXIAL RECEPTACLE-SMA (GPS)		
12	E30-7520-45	DC CORD		
13	E3F-0017-00	FLAT CABLE(20P)		
14	E3F-0019-00	FLAT CABLE(50P)		
15	E3F-0021-10	FLAT CABLE(30P)		
16	E37-1118-05	LEAD WIRE WITH CONNECTOR(SHORT CABLE)		
17	E37-1693-05	LEAD WIRE WITH CONNECTOR(SP 2P)		5900_K
18	E3H-0008-00	LEAD WIRE WITH CONNECTOR(4P)		
20	F10-3223-05	SHIELDING COVER(BLS(IF IC))		
21	F10-3225-05	SHIELDING COVER(BLS(BT/GPS,DCDC54M)) (x2)		
22	F10-3243-15	SHIELDING COVER(BLS(PLL IC))		
23	F1A-0017-00	SHIELDING PLATE(TOP)		
26	F1E-0001-00	SHIELDING PLATE(D-SUB)		
27	F1E-0002-00	SHADE(TX-BUSY)		5900_K
29	G13-1837-04	CUSHION		
31	G1D-0011-00	CUSHION(LCD-HOLDER)		5900_K
32	G1D-0012-10	CUSHION(LCD-F.GLASS)		5900_K
33	G1D-0018-00	CUSHION(D-SUB)		
34	G1D-0028-00	CUSHION(DC SCREW)		
36	G53-1616-13	PACKING(PHONE JACK)		
37	G53-1643-04	PACKING(DC CORD)		
38	G53-1789-04	PACKING(ANT(N))		
39	G53-1768-04	PACKING(SMA)		
40	G5D-0053-00	PACKING(SP)		5900_K
41	G5D-0061-00	PACKING(TOP)		
42	G5D-0017-00	PACKING(FRONT)		
43	J1K-0018-00	HOLDER(LCD)		5900_K
44	J1K-0019-00	HOLDER(PCB PANEL)		5900_K
45	J2B-0021-00	MOUNTING HARDWARE(LCD)		5900_K
46	J2B-0023-00	MOUNTING HARDWARE(SP)		5900_K
47	K2K-0100-10	KEY TOP		5900_K
48	T07-0810-05	SPEAKER		5900_K
49	W09-0971-05	LITHIUM CELL(MAIN UNIT)		
50	G13-1801-04	CUSHION		
51	F0B-0083-00	RADIATION PLATE		
A	N09-2292-05	HEXAGON HEAD SCREW(D-SUB)	(x2)	
B	N30-2606-48	P.HEAD M.SCREW(SMA)	(x2)	
C	N67-3008-48	PAN HEAD SEMS SCREW(DC)	(x2)	
D	N67-3010-43	P.H.SEMS SCREW(FINAL FET)	(x2)	
E	N83-2005-48	PAN HEAD TAPTITE SCREW(MODULE UNIT)	(x3)	
F	N87-2608-48	BRAZIER HEAD TAPTITE SCREW	(x23)	
G	N89-2606-43	BINDING HEAD TAPTITE SCREW(D-SUB)	(x2)	
-	XC1-1021-81	SERVICE MAIN UNIT		
-	XC2-0031-80	MODULE UNIT(BT/GPS)		
-	XC3-0020-20	SUB UNIT(DISPLAY)		5900_K

Electrical parts list

MAIN UNIT

XC1-1021-80

***Note : This part cannot be replaced. Therefore, this part is not supplied as a service part.**

Block No. [0][1]

Symbol No.	Part No.	Part Name	Description	Local
IC1	-----	IC	*Note	
IC2	MSP430G25KGA	IC		
IC3	XC6215B122N-G	IC		
IC4	NJM2878F4-33	IC		
IC5	XC6223D331P-G	IC		
IC6	-----	IC	*Note	
IC7	XC6223H331P-G	IC		
IC8	TPS54240DGQ	IC		
IC9	XC8102AA07-G	IC		
IC10	-----	IC	*Note	
IC11	LXDC2HN18F163	IC		
IC12	NJM2878F4-33	IC		
IC13	TPS61041DRV	IC		
IC14	XC6223H331P-G	IC		
IC15	BA00DD0WHFP	IC		
IC16	XC6209B502P-G	IC		
IC17	-----	IC	*Note	
IC18	XC61CN5002N-G	IC		
IC100	SKY72310362LF	IC		
IC101	TC7SH17FUF	IC		
IC102	BA2904FVM	IC		
IC300	-----	IC	*Note	
IC302	ADL5513	IC		
IC303	NJM12904RB1	IC		
IC304	NJM12904RB1	IC		
IC305	NJM12904RB1	IC		
IC500	AK1224	IC		
IC501	UPG2214TK-A	IC		
IC502	UPG2214TK-A	IC		
IC600	AD9864BCPZRL	IC		
IC701	-----	IC	*Note	
IC702	-----	IC	*Note	
IC703	CDC3S04YFF	IC		
IC704	TC7SZ08FE	IC		
IC705	TC7WH126FU-F	IC		
IC706	-----	IC	*Note	
IC707	BD11600NUX	IC		
IC708	BD11600NUX	IC		
IC709	TC7SET125FUF	IC		
IC710	TC7SZ08FE	IC		
IC711	-----	IC	*Note	
IC712	ADS7961SRHB	IC		
IC714	BD11600NUX	IC		
IC715	DAC124S085CIS	IC		
IC719	R2A20178NP	IC		
IC720	XC61CN5002N-G	IC		
IC900	TC7SET08FUF	IC		
IC901	BU7242NUX	IC		
IC902	TLV32AIC3104I	IC		
IC903	BU7242NUX	IC		
IC904	TC7SET125FUF	IC		
IC905	TC7WT125FUF	IC		
IC906	TC7WBD125AFK	IC		
IC907	BD11600NUX	IC		
IC908	TC7WH14FK-F	IC		
IC909	ADM3202ARUZ	IC		
IC910	PCA9555AHF	IC		
IC912	TC7SET08FUF	IC		
Q1	KTA2012EP	TRANSISTOR		
Q3	SSM3K15AMFV	FET		
Q4	LTC014EEBFS8	DIGI TRANSISTOR		
Q5	MTM981400BF	FET		
Q6	LTC014EEBFS8	DIGI TRANSISTOR		
Q7	LTC014TEBFS8	DIGI TRANSISTOR		
Q8	LSCR523EBFS8	TRANSISTOR		
Q9	LSAR523UBFS8	TRANSISTOR		
Q10	MTM981400BF	FET		

Symbol No.	Part No.	Part Name	Description	Local
Q11	LTC014EEBFS8	DIGI TRANSISTOR		
Q12	EM6M2	FET		
Q14	EM6M2	FET		
Q15	LTC014EEBFS8	DIGI TRANSISTOR		
Q16	SSM3J334R	FET		
Q17	LTC014EEBFS8	DIGI TRANSISTOR		
Q18	SSM3J334R	FET		
Q81	SSM3J15FS	FET		
Q102	MCH3914-H/8/	FET		
Q103	EM6M2	FET		
Q104	MCH3914-H/8/	FET		
Q105	2SC5108F/Y/	TRANSISTOR		
Q106	2SC5108F/Y/	TRANSISTOR		
Q107	2SC5108F/Y/	TRANSISTOR		
Q108	DSC9A01/T/	TRANSISTOR		
Q110	EM6M2	FET		
Q113	SSM3J15FS	FET		
Q115	EM6M2	FET		
Q300	RD01MUS2-T113	FET		
Q301	NE5550234	FET		
Q302	RD10MMS2-T212	FET		
Q303	-----	FET		*Note
Q304	SSM3K15AMFV	FET		
Q305	LSCR523EBFS8	TRANSISTOR		
Q306	LSCR523EBFS8	TRANSISTOR		
Q307	LSCR523EBFS8	TRANSISTOR		
Q308	EM6M2	FET		
Q309	SSM3K15AMFV	FET		
Q500	2SC5108F/Y/	TRANSISTOR		
Q501	MT3S111	TRANSISTOR		
Q502	MT3S111	TRANSISTOR		
Q503	SSM3J15FS	FET		
Q504	EM6M2	FET		
Q600	MCH3914-H/8/	FET		
Q601	LTC023JEBFS8	DIGI TRANSISTOR		
Q602	LSCR523EBFS8	TRANSISTOR		
Q603	2SC5066F/O/	TRANSISTOR		
Q604	BB506CFS-H	FET		
Q700	2SC4617/S/	TRANSISTOR		
Q701	SSM3K15AMFV	FET		
Q703	SSM3K15AMFV	FET		
Q704	SSM3K15AMFV	FET		
Q705	LTC014TEBFS8	DIGI TRANSISTOR		
Q900	SSM3K335R	FET		
Q901	SSM3J332R	FET		
Q902	DSC9A01/T/	TRANSISTOR		
Q905	SSM3K335R	FET		
Q906	SSM3J332R	FET		
Q907	SSM3K335R	FET		
Q908	SSM3K335R	FET		
D1	DZ2J180(M)	ZENER DIODE		
D2	RB520SM-30	DIODE		
D3	EDZV8.2B	ZENER DIODE		
D4	RB521CM-30	DIODE		
D5	22ZR-10D	SURGE ABSORBER		
D6	RB520SM-30	DIODE		
D7	RB521CM-30	DIODE		
D8	RB521CM-30	DIODE		
D9	RB521CM-30	DIODE		
D10	DSA3A1	DIODE		
D11	DZ2S056(M)	ZENER DIODE		
D12	RB521CM-30	DIODE		
D13	1SS400SM	DIODE		
D14	RB060M-40	DIODE		
D15	DB2J40700	DIODE		
D16	RB521CM-30	DIODE		
D17	RB521CM-30	DIODE		
D100	EDZV8.2B	ZENER DIODE		
D106	SMV1705-079LF	VARIABLE CAPACITANCE DIODE		
D107	SMV1130-079LF	VARIABLE CAPACITANCE DIODE		
D108	SMV1130-079LF	VARIABLE CAPACITANCE DIODE		
D109	SMV1130-079LF	VARIABLE CAPACITANCE DIODE		
D110	SMV1801-079LF	VARIABLE CAPACITANCE DIODE		
D111	SMV1705-079LF	VARIABLE CAPACITANCE DIODE		
D112	SMV1130-079LF	VARIABLE CAPACITANCE DIODE		

△ Symbol No.	Part No.	Part Name	Description	Local	△ Symbol No.	Part No.	Part Name	Description	Local
D113	SMV1130-079LF	VARIABLE CAPACITANCE DIODE			C35	CK73HBB1H471K	C CAPACITOR	470PF K	
D114	SMV1130-079LF	VARIABLE CAPACITANCE DIODE			C36	CK73GB1H105K	C CAPACITOR	1.0UF K	
D115	1SS400SM	DIODE			C37	CK73FB1C106K	C CAPACITOR	10.0UF K	
D117	SMV1130-079LF	VARIABLE CAPACITANCE DIODE			C38	CK73HBB1H471K	C CAPACITOR	470PF K	
D300	RN262CS	DIODE			C39	CK73GB0J106K	C CAPACITOR	10.0UF K	
D304	RB706F-40	DIODE			C40	CK73HB1H103K	C CAPACITOR	10000PF K	
D305	L8104	DIODE			C41	CK73GB1H105K	C CAPACITOR	1.0UF K	
D306	L8104	DIODE			C43	CK73GXR1C225K	C CAPACITOR	2.2UF K	
D307	CSA30-201N	DIODE			C44	CK73HBB1H471K	C CAPACITOR	470PF K	
D308	L8104	DIODE			C45	CK73HB1C105K	C CAPACITOR	1.0UF K	
D310	RN142S	DIODE			C46	CK73GXR1C225K	C CAPACITOR	2.2UF K	
D311	RN142S	DIODE			C47	CK73HB1E104K	C CAPACITOR	0.10UF K	
D312	DZ2S056(M)	ZENER DIODE			C48	CK73GXR1C225K	C CAPACITOR	2.2UF K	
D313	DZ2S056(M)	ZENER DIODE			C49	CK73HB1C105K	C CAPACITOR	1.0UF K	
D314	RB520SM-30	DIODE			C50	CK73HBB1H102K	C CAPACITOR	1000PF K	
D500	RN262CS	DIODE			C51	CK73HBB1H332K	C CAPACITOR	3300PF K	
D505	RN142S	DIODE			C52	CK73HB1E104K	C CAPACITOR	0.10UF K	
D506	RN142S	DIODE			C53	CK73GB1H105K	C CAPACITOR	1.0UF K	
D600	SMV1705-079LF	VARIABLE CAPACITANCE DIODE			C54	CK73GB1H105K	C CAPACITOR	1.0UF K	
D601	SMV1705-079LF	VARIABLE CAPACITANCE DIODE			C55	CK73HBB1H471K	C CAPACITOR	470PF K	
D602	DA3S101F	MULTIPLE DIODE			C56	CK73HB1H392K	C CAPACITOR	3900PF K	
D700	RB521CM-30	DIODE			C57	CK73FXR1E475K	C CAPACITOR	4.7UF K	
D701	RB521CM-30	DIODE			C58	CC73HCH1H220G	C CAPACITOR	22PF G	
D702	SPC10501A01	VARISTOR			C59	CK73FB1C106K	C CAPACITOR	10.0UF K	
D703	SPC10501A01	VARISTOR			C60	CK73FB1C106K	C CAPACITOR	10.0UF K	
D704	SPC10501A01	VARISTOR			C61	CK73HBB1H471K	C CAPACITOR	470PF K	
D705	SPC10501A01	VARISTOR			C62	CK73GXR1C225K	C CAPACITOR	2.2UF K	
D706	SPC10501A01	VARISTOR			C63	CK73HBB1H102K	C CAPACITOR	1000PF K	
D708	EDZV8.2B	ZENER DIODE			C64	CK73GB0J106K	C CAPACITOR	10.0UF K	
D710	RB521CM-30	DIODE			C65	CK73FB1C106K	C CAPACITOR	10.0UF K	
D711	RB521CM-30	DIODE			C66	CK73HB1C105K	C CAPACITOR	1.0UF K	
D801	RB521CM-30	DIODE			C67	CK73FB1C106K	C CAPACITOR	10.0UF K	
D900	DA3S101F	MULTIPLE DIODE			C68	CK73FXR1E475K	C CAPACITOR	4.7UF K	
D903	DZ2S056(M)	ZENER DIODE			C69	CK73GXR1C225K	C CAPACITOR	2.2UF K	
D904	DA204U	MULTIPLE DIODE			C70	CK73HB1H391K	C CAPACITOR	390PF K	
D905	1SS400SM	DIODE			C71	CK73HB1H391K	C CAPACITOR	390PF K	
D906	DZ2S056(M)	ZENER DIODE			C72	CK730FA1H475K	C CAPACITOR	4.7UF K	
D907	RB521CM-30	DIODE			C73	CK73GB1H105K	C CAPACITOR	1.0UF K	
D908	DA204U	MULTIPLE DIODE			C74	CK73GXR1C225K	C CAPACITOR	2.2UF K	
D909	DA3S101F	MULTIPLE DIODE			C75	CK73HB1C105K	C CAPACITOR	1.0UF K	
D910	DA204U	MULTIPLE DIODE			C76	CK73HBB1H471K	C CAPACITOR	470PF K	
D911	DA204U	MULTIPLE DIODE			C77	CK73FXR1E475K	C CAPACITOR	4.7UF K	
D912	DA204U	MULTIPLE DIODE			C78	CK730DT1C476K	C CAPACITOR	4.7UF K	
D913	DA204U	MULTIPLE DIODE			C80	CK73GXR1H104K	C CAPACITOR	0.1UF K	
D914	DA204U	MULTIPLE DIODE			C81	CC73HCH1H470G	C CAPACITOR	47PF G	
D915	DA204U	MULTIPLE DIODE			C82	CK73GXR1C225K	C CAPACITOR	2.2UF K	
D916	DA2J101	DIODE			C83	CK73HB1C105K	C CAPACITOR	1.0UF K	
D917	DZ2J180(M)	ZENER DIODE			C84	CK73GXR1C225K	C CAPACITOR	2.2UF K	
D918	DA204U	MULTIPLE DIODE			C85	C92-0968-05	E CAPACITOR	470UF 25WV	
D919	DA204U	MULTIPLE DIODE			C100	CK73HB1H103K	C CAPACITOR	10000PF K	
D920	DA204U	MULTIPLE DIODE			C101	CK73HBB1H471K	C CAPACITOR	470PF K	
D921	DA2J101	DIODE			C102	CC73HCH1H100B	C CAPACITOR	10PF B	
D922	DZ2J180(M)	ZENER DIODE			C103	CK73HB1H103K	C CAPACITOR	10000PF K	
D923	DA204U	MULTIPLE DIODE			C104	CK73HB1H103K	C CAPACITOR	10000PF K	
D924	RB520SM-30	DIODE			C106	CC73HCH1H101J	C CAPACITOR	100PF J	
C1	CK73HB1C105K	C CAPACITOR	1.0UF K		C107	CC73HCH1H101J	C CAPACITOR	100PF J	
C2	CD04CK1E102M	E CAPACITOR	1000UF M		C108	CC73HCH1H101J	C CAPACITOR	100PF J	
C3	CK73HBB1H222K	C CAPACITOR	2200PF K		C109	CC73HCH1H101J	C CAPACITOR	100PF J	
C4	CK73HBB1H471K	C CAPACITOR	470PF K		C110	CC73HCH1H101J	C CAPACITOR	100PF J	
C5	CK73HBB1H471K	C CAPACITOR	470PF K		C111	CC73HCH1H101J	C CAPACITOR	100PF J	
C7	CC73HCH1H470G	C CAPACITOR	47PF G		C112	CK73HB1E104K	C CAPACITOR	0.10UF K	
C8	CK73HBB1H102K	C CAPACITOR	1000PF K		C113	CK73HB1E104K	C CAPACITOR	0.10UF K	
C9	CK73HBB1H471K	C CAPACITOR	470PF K		C114	CC73HCH1H101J	C CAPACITOR	100PF J	
C10	CK73FB1C106K	C CAPACITOR	10.0UF K		C115	CK73HB1E104K	C CAPACITOR	0.10UF K	
C11	CK73HB1E104K	C CAPACITOR	0.10UF K		C116	CC73HCH1H101J	C CAPACITOR	100PF J	
C12	C93-1959-05	C CAPACITOR	0.10UF B		C118	CK73HB1H103K	C CAPACITOR	10000PF K	
C13	CK73HB1A474K	C CAPACITOR	0.47UF K		C120	CC73HCH1H101J	C CAPACITOR	100PF J	
C16	CK73HB1H103K	C CAPACITOR	10000PF K		C121	CC73HCH1H330G	C CAPACITOR	33PF G	
C18	CK73HBB1H471K	C CAPACITOR	470PF K		C124	CC73HCH1H101J	C CAPACITOR	100PF J	
C21	CK73HB1C105K	C CAPACITOR	1.0UF K		C125	CK73GB1H105K	C CAPACITOR	1.0UF K	
C24	CK73HBB1H471K	C CAPACITOR	470PF K		C126	CC73HCH1H101J	C CAPACITOR	100PF J	
C25	CK73HBB1H102K	C CAPACITOR	1000PF K		C127	CK73FBB1H154K	C CAPACITOR	0.15UF K	
C30	CK73HB1C105K	C CAPACITOR	1.0UF K		C128	CS77ABE1D100M	TA E CAPACITOR	10UF M	
C31	CK73EB1H475KM	C CAPACITOR	4.7UF K		C130	CK73FB1H473K	C CAPACITOR	0.047UF K	
C32	CK73GB1H105K	C CAPACITOR	1.0UF K		C131	CC730AD1H104J	C CAPACITOR	100PF J	
C33	CK73EB1H475KM	C CAPACITOR	4.7UF K		C140	CC73HCH1H050B	C CAPACITOR	5.0PF B	
C34	CK73HB1E104K	C CAPACITOR	0.10UF K		C141	CC73HCH1H151J	C CAPACITOR	150PF J	
					C143	CC73HCH1H240G	C CAPACITOR	24PF G	

△ Symbol No.	Part No.	Part Name	Description	Local	△ Symbol No.	Part No.	Part Name	Description	Local
C144	CC73HCH1HR75B	C CAPACITOR	0.75PF B		C322	CC73HCH1H470G	C CAPACITOR	47PF G	
C145	CC73HCH1HOR5B	C CAPACITOR	0.5PF B		C323	CC73HCH1H470G	C CAPACITOR	47PF G	
C146	CC73HCH1H060B	C CAPACITOR	6.0PF B		C324	CC73HCH1H070B	C CAPACITOR	7.0PF B	
C147	CC73HCH1H080B	C CAPACITOR	8.0PF B		C325	CC73HCH1H060B	C CAPACITOR	6.0PF B	
C148	CC73HCH1H060B	C CAPACITOR	6.0PF B		C326	CC73HCH1H150G	C CAPACITOR	15PF G	
C149	CK73HBB1H471K	C CAPACITOR	470PF K		C327	CC73GCH1H040B	C CAPACITOR	4.0PF B	
C150	CC73HCH1HOR5B	C CAPACITOR	0.5PF B		C328	CC73HCH1H470G	C CAPACITOR	47PF G	
C151	CC73HCH1H101J	C CAPACITOR	100PF J		C329	CC73GCH1H050B	C CAPACITOR	5.0PF B	
C152	CK73HBB1H471K	C CAPACITOR	470PF K		C330	CC73HCH1H470G	C CAPACITOR	47PF G	
C154	CC73HCH1H101J	C CAPACITOR	100PF J		C331	CC73GCH1H470J	C CAPACITOR	47PF J	
C155	CC73HCH1H030B	C CAPACITOR	3.0PF B		C332	CC73GCH1H470J	C CAPACITOR	47PF J	
C156	CC73HCH1H151J	C CAPACITOR	150PF J		C333	CC73GCH1H2R5B	C CAPACITOR	2.5PF B	
C158	CC73HCH1H060B	C CAPACITOR	6.0PF B		C334	CK73GXR1H104K	C CAPACITOR	0.1UF K	
C159	CC73HCH1H2R5B	C CAPACITOR	2.5PF B		C335	CC73GCH1H150J	C CAPACITOR	15.0F J	
C160	CC73HCH1H080B	C CAPACITOR	8.0PF B		C336	CC73GCH1H060B	C CAPACITOR	6.0F B	
C161	CC73HCH1H080B	C CAPACITOR	8.0PF B		C337	CC73GCH1H110G	C CAPACITOR	11PF G	
C162	CC73HCH1H070B	C CAPACITOR	7.0PF B		C339	CC73GCH1H060B	C CAPACITOR	6.0PF B	
C163	CK73HBB1H471K	C CAPACITOR	470PF K		C340	CC73GCH1H220J	C CAPACITOR	22PF J	
C164	CC73HCH1HOR5B	C CAPACITOR	0.5PF B		C342	CC73GCH1H470J	C CAPACITOR	47PF J	
C165	CK73HBB1H471K	C CAPACITOR	470PF K		C343	CC73GCH1H470J	C CAPACITOR	47PF J	
C166	CC73HCH1H020G	C CAPACITOR	2.0PF B		C345	CC73GCH1H470J	C CAPACITOR	47PF J	
C167	CC73HCH1H470G	C CAPACITOR	47PF G		C346	CC73GCH1H101J	C CAPACITOR	100PF J	
C168	CK73HB1E104K	C CAPACITOR	0.10UF K		C347	CK73GXR1H104K	C CAPACITOR	0.1UF K	
C169	CC73HCH1H470G	C CAPACITOR	47PF G		C348	C93-0938-05	C CAPACITOR	13PF G	
C170	CC73HCH1H1R5B	C CAPACITOR	1.5PF B		C349	CC73GCH1H470J	C CAPACITOR	47PF J	
C171	CC73HCH1H470G	C CAPACITOR	47PF G		C351	C93-0980-05	C CAPACITOR	5.0PF B	
C172	CC73HCH1H100B	C CAPACITOR	10PF B		C350	CC73GCH1H470J	C CAPACITOR	47PF J	
C173	CC73HCH1H1R5B	C CAPACITOR	1.5PF B		C353	C93-0938-05	C CAPACITOR	13PF G	
C174	CC73HCH1H100B	C CAPACITOR	10PF B		C355	CC73GCH1H470J	C CAPACITOR	47PF J	
C175	CC73HCH1H060B	C CAPACITOR	6.0PF B		C356	C93-0875-05	C CAPACITOR	1.5PF B	
C176	CC73HCH1H060B	C CAPACITOR	6.0PF B		C357	CC73GCH1H470J	C CAPACITOR	47PF J	
C177	CC73HCH1H020B	C CAPACITOR	2.0PF B		C358	C93-0897-05	C CAPACITOR	8.0PF C	
C178	CC73HCH1H050B	C CAPACITOR	5.0PF B		C359	C93-0897-05	C CAPACITOR	8.0PF C	
C179	CC73HCH1H020B	C CAPACITOR	2.0PF B		C360	C93-1863-05	C CAPACITOR	15PF G	
C180	CC73HCH1HOR5B	C CAPACITOR	0.5PF B		C367	C93-0939-05	C CAPACITOR	15PF G	
C181	CC73HCH1H050B	C CAPACITOR	5.0PF B		C369	CC73HCH1H470G	C CAPACITOR	47PF G	
C182	CC73HCH1H060B	C CAPACITOR	6.0PF B		C370	C93-0939-05	C CAPACITOR	15PF G	
C183	CC73HCH1H470G	C CAPACITOR	47PF G		C373	C93-1864-05	C CAPACITOR	18PF B	
C184	CC73HCH1H030B	C CAPACITOR	3.0PF B		C374	C93-1864-05	C CAPACITOR	18PF B	
C185	CC73HCH1H030B	C CAPACITOR	3.0PF B		C375	C93-1864-05	C CAPACITOR	18PF B	
C186	CC73HCH1H470G	C CAPACITOR	47PF G		C376	C93-1864-05	C CAPACITOR	18PF B	
C187	CC73HCH1H470G	C CAPACITOR	47PF G		C377	C93-1857-05	C CAPACITOR	8.0PF B	
C188	CK73HB1E104K	C CAPACITOR	0.10UF K		C378	C93-1857-05	C CAPACITOR	8.0PF B	
C189	CC73HCH1H470G	C CAPACITOR	47PF G		C387	C93-1859-05	C CAPACITOR	9.0PF B	
C190	CK73HB1C105K	C CAPACITOR	1.0UF K		C392	C93-1864-05	C CAPACITOR	18PF B	
C191	CC73HCH1H101J	C CAPACITOR	100PF J		C393	CK73HBB1H472K	C CAPACITOR	4700PF K	
C192	CK73FB1C106K	C CAPACITOR	10.0UF K		C394	CC73GCH1H470J	C CAPACITOR	47PF J	
C194	CC73HCH1H470G	C CAPACITOR	47PF G		C395	CK73GBB1H102K	C CAPACITOR	1000PF K	
C195	CK73GB1H105K	C CAPACITOR	1.0UF K		C396	CK73GBB1H103K	C CAPACITOR	0.10UF K	
C198	CK73HB1C105K	C CAPACITOR	1.0UF K		C399	CC73HCH1H470G	C CAPACITOR	47PF G	
C199	CC73HCH1H101J	C CAPACITOR	100PF J		C404	CC73GCH1H470J	C CAPACITOR	47PF J	
C202	CC73HCH1H101J	C CAPACITOR	100PF J		C405	CC73GCH1H470J	C CAPACITOR	47PF J	
C203	CC73HCH1H101J	C CAPACITOR	100PF J		C406	C93-1835-05	C CAPACITOR	1.5PF B	
C204	CC73HCH1H101J	C CAPACITOR	100PF J		C407	C93-1864-05	C CAPACITOR	18PF B	
C211	CC73HCH1H010B	C CAPACITOR	1.0PF B		C408	CK73HBB1H222K	C CAPACITOR	2200PF K	
C212	CC73HCH1H020B	C CAPACITOR	2.0PF B		C410	CC73HCH1H470G	C CAPACITOR	47PF G	
C213	CC73HCH1H470G	C CAPACITOR	47PF G		C411	CC73GCH1H470J	C CAPACITOR	47PF J	
C300	CC73HCH1H101J	C CAPACITOR	100PF J		C412	C93-1838-05	C CAPACITOR	2.0PF B	
C301	CC73HCH1H040B	C CAPACITOR	4.0PF B		C413	C93-1869-05	C CAPACITOR	47PF B	
C302	CC73HCH1H470G	C CAPACITOR	47PF G		C415	C93-1844-05	C CAPACITOR	3.6PF B	
C303	CC73HCH1H090B	C CAPACITOR	9.0PF B		C416	C93-2004-05	C CAPACITOR	3.3PF B	
C304	CC73HCH1HR75B	C CAPACITOR	0.75PF B		C417	C93-2004-05	C CAPACITOR	3.3PF B	
C305	CC73HCH1H090B	C CAPACITOR	9.0PF B		C418	C93-2004-05	C CAPACITOR	3.3PF B	
C306	CK73HBB1H471K	C CAPACITOR	470PF K		C419	C93-2004-05	C CAPACITOR	3.3PF B	
C307	CC73HCH1H470G	C CAPACITOR	47PF G		C420	C93-1844-05	C CAPACITOR	3.6PF B	
C308	CC73HCH1H060B	C CAPACITOR	6.0PF B		C421	CC73GCH1H040B	C CAPACITOR	4.0PF B	
C309	CK73HBB1H152K	C CAPACITOR	1500PF K		C423	CC73HCH1H470G	C CAPACITOR	47PF G	
C310	CC73HCH1H470G	C CAPACITOR	47PF G		C427	CC73HCH1H101J	C CAPACITOR	100PF J	
C311	CK73HB1E473K	C CAPACITOR	47000PF K		C428	CK73HB1E473K	C CAPACITOR	47000PF K	
C313	CK73HBB1H152K	C CAPACITOR	1500PF K		C429	CK73HB1E473K	C CAPACITOR	47000PF K	
C314	CC73HCH1H470G	C CAPACITOR	47PF G		C430	CC73HCH1H101J	C CAPACITOR	100PF J	
C315	CK73HBB1H152K	C CAPACITOR	1500PF K		C431	CC73HCH1H101J	C CAPACITOR	100PF J	
C316	CC73HCH1H070B	C CAPACITOR	7.0PF B		C432	CK73HBB1H471K	C CAPACITOR	470PF K	
C317	CC73HCH1H470G	C CAPACITOR	47PF G		C433	CK73HBB1H222K	C CAPACITOR	2200PF K	
C318	CC73HCH1H040B	C CAPACITOR	4.0PF B		C434	CK73GBB1H333K	C CAPACITOR	0.033UF K	
C319	CC73HCH1H470G	C CAPACITOR	47PF G		C435	CK73HB1H103K	C CAPACITOR	10000PF K	
C320	CC73HCH1H060B	C CAPACITOR	6.0PF B		C436	CK73HBB1H472K	C CAPACITOR	0.047UF K	
C321	CK73GXR1H104K	C CAPACITOR	0.1UF K		C437	CK73HB1E473K	C CAPACITOR	47000PF K	

△ Symbol No.	Part No.	Part Name	Description	Local	△ Symbol No.	Part No.	Part Name	Description	Local
C438	CK73HB1H103K	C CAPACITOR	10000PF K		C616	CC73HCH1H330G	C CAPACITOR	33PF G	
C439	CK73HBB1H332K	C CAPACITOR	3300PF K		C617	CC73HCH1H330G	C CAPACITOR	33PF G	
C440	CK73HB1E333K	C CAPACITOR	33000PF K		C618	CK73HB1H103K	C CAPACITOR	10000PF K	
C441	CK73HBB1H332K	C CAPACITOR	3300PF K		C619	C93-1959-05	C CAPACITOR	0.10UF B	
C443	CK73HB1H103K	C CAPACITOR	10000PF K		C620	CK73HB1C105K	C CAPACITOR	1.0UF K	
C444	CK73HB1H103K	C CAPACITOR	10000PF K		C621	CK73HB1H103K	C CAPACITOR	10000PF K	
C445	CK73HB1H103K	C CAPACITOR	10000PF K		C622	CK73HBB1H102K	C CAPACITOR	1000PF K	
C446	CK73HBB1H332K	C CAPACITOR	3300PF K		C623	CC73HCH1H030B	C CAPACITOR	3.0PF B	
C447	CK73HBB1H682K	C CAPACITOR	6800PF K		C624	CC73HCH1H390G	C CAPACITOR	39PF G	
C448	CC73GCH1H470J	C CAPACITOR	47PF J		C625	C93-1959-05	C CAPACITOR	0.10UF B	
C457	C93-0938-05	C CAPACITOR	13PF G		C626	CK73HB1E104K	C CAPACITOR	0.10UF K	
C458	C93-0938-05	C CAPACITOR	13PF G		C627	C93-1953-05	C CAPACITOR	0.10UF B	
C500	CK73HB1H103K	C CAPACITOR	10000PF K		C628	C93-1959-05	C CAPACITOR	0.10UF B	
C501	CC73HCH1H470G	C CAPACITOR	47PF G		C629	C93-1953-05	C CAPACITOR	0.10UF B	
C502	CK73HB1H103K	C CAPACITOR	10000PF K		C630	C93-1959-05	C CAPACITOR	0.10UF B	
C503	CC73HCH1H101J	C CAPACITOR	100PF J		C631	C93-1959-05	C CAPACITOR	0.10UF B	
C504	CK73HB1H103K	C CAPACITOR	10000PF K		C632	C93-1953-05	C CAPACITOR	0.10UF B	
C505	CC73HCH1H101J	C CAPACITOR	100PF J		C633	C93-1959-05	C CAPACITOR	0.10UF B	
C506	CK73HB1E104K	C CAPACITOR	0.10UF K		C634	CK73FB1C106K	C CAPACITOR	10.0UF K	
C507	CC73HCH1H101J	C CAPACITOR	100PF J		C635	C93-1959-05	C CAPACITOR	0.10UF B	
C508	CC73HCH1H2R5B	C CAPACITOR	2.5PF B		C636	CK73HB1C105K	C CAPACITOR	1.0UF K	
C509	CC73HCH1H101J	C CAPACITOR	100PF J		C637	CK73HB1H103K	C CAPACITOR	10000PF K	
C510	CC73HCH1H2R5B	C CAPACITOR	2.5PF B		C638	CK73HBB1H682K	C CAPACITOR	6800PF K	
C511	CK73HB1H103K	C CAPACITOR	10000PF K		C639	CC73HCH1H101J	C CAPACITOR	100PF J	
C512	CC73HCH1H030B	C CAPACITOR	3.0PF B		C640	C93-1969-05	C CAPACITOR	1000PF G	
C513	CC73HCH1H050B	C CAPACITOR	5.0PF B		C641	CC73HCH1H101J	C CAPACITOR	100PF J	
C514	CC73HCH1H030B	C CAPACITOR	3.0PF B		C642	CC73HCH1H100B	C CAPACITOR	10PF B	
C516	CC73HCH1H470G	C CAPACITOR	47PF G		C643	CC73JCH1H101J	C CAPACITOR	100PF J	
C517	CC73HCH1H101J	C CAPACITOR	100PF J		C644	C93-1953-05	C CAPACITOR	0.10UF B	
C518	CC73HCH1H101J	C CAPACITOR	100PF J		C645	CC73HCH1H220G	C CAPACITOR	22PF G	
C519	CK73HB1H103K	C CAPACITOR	10000PF K		C646	CC73HCH1H151J	C CAPACITOR	150PF J	
C520	CK73HB1H103K	C CAPACITOR	10000PF K		C647	C93-1959-05	C CAPACITOR	0.10UF B	
C521	CC73HCH1H470G	C CAPACITOR	47PF G		C648	CC73JCH1H101J	C CAPACITOR	100PF J	
C522	CC73HCH1H470G	C CAPACITOR	47PF G		C649	CC73HCH1H100B	C CAPACITOR	10PF B	
C525	CC73HCH1H470G	C CAPACITOR	47PF G		C650	CC73HCH1H101J	C CAPACITOR	100PF J	
C526	CC73HCH1H470G	C CAPACITOR	47PF G		C651	C93-1959-05	C CAPACITOR	0.10UF B	
C527	CC73HCH1H100B	C CAPACITOR	10PF B		C652	C93-1959-05	C CAPACITOR	0.10UF B	
C528	CC73HCH1H100B	C CAPACITOR	10PF B		C653	CC73HCH1H560J	C CAPACITOR	56PF J	
C530	CK73HB1H103K	C CAPACITOR	10000PF K		C654	CK73HBB1H102K	C CAPACITOR	1000PF K	
C531	CC73HCH1H470G	C CAPACITOR	47PF G		C655	CK73HB1H103K	C CAPACITOR	10000PF K	
C532	CK73HB1H103K	C CAPACITOR	10000PF K		C656	CC73HCH1H100B	C CAPACITOR	10PF B	
C533	CC73HCH1H100B	C CAPACITOR	10PF B		C657	CC73HCH1H060B	C CAPACITOR	6.0PF B	
C534	CC73HCH1H470G	C CAPACITOR	47PF G		C658	CK73HB1H103K	C CAPACITOR	10000PF K	
C535	CC73HCH1H470G	C CAPACITOR	47PF G		C659	CK73HB1H103K	C CAPACITOR	10000PF K	
C536	CC73HCH1H470G	C CAPACITOR	47PF G		C660	CC73HCH1H120G	C CAPACITOR	12PF G	
C537	CC73HCH1H470G	C CAPACITOR	47PF G		C661	CK73HBB1H102K	C CAPACITOR	1000PF K	
C538	CC73HCH1H470G	C CAPACITOR	47PF G		C662	CK73HBB1H102K	C CAPACITOR	1000PF K	
C539	CC73HCH1H470G	C CAPACITOR	47PF G		C663	CK73HB1H103K	C CAPACITOR	10000PF K	
C540	CC73HCH1H470G	C CAPACITOR	47PF G		C665	CC73HCH1H050B	C CAPACITOR	5.0PF B	
C541	CC73HCH1H470G	C CAPACITOR	47PF G		C666	CC73HCH1H150G	C CAPACITOR	15PF G	
C542	CC73HCH1H060B	C CAPACITOR	6.0PF B		C668	CC73HCH1H180G	C CAPACITOR	18PF G	
C543	CC73HCH1H070B	C CAPACITOR	7.0PF B		C671	CC73HCH1H180G	C CAPACITOR	18PF G	
C544	CC73HCH1H101J	C CAPACITOR	100PF J		C681	CK73HBB1H471K	C CAPACITOR	470PF K	
C545	CC73HCH1H101J	C CAPACITOR	100PF J		C700	CK73HB1C105K	C CAPACITOR	1.0UF K	
C552	CC73HCH1H090B	C CAPACITOR	9.0PF B		C701	C93-1959-05	C CAPACITOR	0.10UF B	
C553	CC73HCH1H090B	C CAPACITOR	9.0PF B		C702	C93-1959-05	C CAPACITOR	0.10UF B	
C556	CC73HCH1H101J	C CAPACITOR	100PF J		C703	CK73FXR0J226M	C CAPACITOR	22UF M	
C557	CC73HCH1H101J	C CAPACITOR	100PF J		C704	CK73HB1H103K	C CAPACITOR	10000PF K	
C558	CC73HCH1H470G	C CAPACITOR	47PF G		C705	C93-1959-05	C CAPACITOR	0.10UF B	
C559	CK73HB1E104K	C CAPACITOR	0.10UF K		C706	C93-1959-05	C CAPACITOR	0.10UF B	
C561	CC73HCH1H101J	C CAPACITOR	100PF J		C707	CK73FXR0J226M	C CAPACITOR	22UF M	
C562	CC73HCH1H010B	C CAPACITOR	1.0PF B		C708	CK73GB0J106K	C CAPACITOR	10.0UF K	
C600	CC73JCH1H101J	C CAPACITOR	100PF J		C709	C93-1959-05	C CAPACITOR	0.10UF B	
C601	CC73JCH1H101J	C CAPACITOR	100PF J		C711	C93-1959-05	C CAPACITOR	0.10UF B	
C602	CC73JCH1H101J	C CAPACITOR	100PF J		C712	C93-1959-05	C CAPACITOR	0.10UF B	
C603	CC73JCH1H101J	C CAPACITOR	100PF J		C713	C93-1959-05	C CAPACITOR	0.10UF B	
C604	CC73JCH1H101J	C CAPACITOR	100PF J		C714	C93-1959-05	C CAPACITOR	0.10UF B	
C605	CC73JCH1H101J	C CAPACITOR	100PF J		C715	C93-1959-05	C CAPACITOR	0.10UF B	
C606	CC73JCH1H101J	C CAPACITOR	100PF J		C716	C93-1959-05	C CAPACITOR	0.10UF B	
C607	CC73HCH1H120G	C CAPACITOR	12PF G		C717	C93-1959-05	C CAPACITOR	0.10UF B	
C608	CK73HB1E104K	C CAPACITOR	0.10UF K		C718	C93-1959-05	C CAPACITOR	0.10UF B	
C609	CK73HB1E562K	C CAPACITOR	5600PF K		C719	CC73JCH1H101J	C CAPACITOR	100PF J	
C610	C93-1959-05	C CAPACITOR	0.10UF B		C720	CK73HB1E104K	C CAPACITOR	0.10UF K	
C611	CC73HCH1H030B	C CAPACITOR	3.0PF B		C721	C93-1959-05	C CAPACITOR	0.10UF B	
C612	CK73HB1A224K	C CAPACITOR	0.22UF K		C722	CC73JCH1H101J	C CAPACITOR	100PF J	
C613	C93-1959-05	C CAPACITOR	0.10UF B		C723	C93-1959-05	C CAPACITOR	0.10UF B	
C614	CK73HB1H123K	C CAPACITOR	12000PF K		C724	C93-1959-05	C CAPACITOR	0.10UF B	
C615	CK73HB1E104K	C CAPACITOR	0.10UF K		C725	CC73JCH1H101J	C CAPACITOR	100PF J	

△ Symbol No.	Part No.	Part Name	Description	Local	△ Symbol No.	Part No.	Part Name	Description	Local
C726	C93-1953-05	C CAPACITOR	0.10UF B		C814	CC73HCH1H101J	C CAPACITOR	100PF J	
C728	CK73GB0J106K	C CAPACITOR	10.0UF K		C815	CC73HCH1H101J	C CAPACITOR	100PF J	
C729	CK73HB1H103K	C CAPACITOR	10000PF K		C816	CC73HCH1H101J	C CAPACITOR	100PF J	
C730	CK73GB0J106K	C CAPACITOR	10.0UF K		C817	CK73HBB1H102K	C CAPACITOR	1000PF K	
C731	C93-1959-05	C CAPACITOR	0.10UF B		C818	CC73HCH1H101J	C CAPACITOR	100PF J	
C732	C93-1959-05	C CAPACITOR	0.10UF B		C819	CK73HB1H103K	C CAPACITOR	10000PF K	
C733	C93-1959-05	C CAPACITOR	0.10UF B		C820	CK73HB1E104K	C CAPACITOR	0.10UF K	
C734	C93-1959-05	C CAPACITOR	0.10UF B		C821	CC73HCH1H101J	C CAPACITOR	100PF J	
C735	CC73JCH1H101J	C CAPACITOR	100PF J		C822	CC73HCH1H101J	C CAPACITOR	100PF J	
C736	C93-1959-05	C CAPACITOR	0.10UF B		C824	CK73HBB1H102K	C CAPACITOR	1000PF K	
C737	CC73JCH1H101J	C CAPACITOR	100PF J		C829	CK73HB1C105K	C CAPACITOR	1.0UF K	
C738	CC73JCH1H101J	C CAPACITOR	100PF J		C830	C93-1959-05	C CAPACITOR	0.10UF B	
C739	CK73GB0J106K	C CAPACITOR	10.0UF K		C831	C93-1959-05	C CAPACITOR	0.10UF B	
C740	CK73HB1H103K	C CAPACITOR	10000PF K		C834	CK73HB1C105K	C CAPACITOR	1.0UF K	
C741	C93-1959-05	C CAPACITOR	0.10UF B		C835	CC73HCH1H101J	C CAPACITOR	100PF J	
C742	CK73GB0J106K	C CAPACITOR	10.0UF K		C839	CK73HB1E104K	C CAPACITOR	0.10UF K	
C743	C93-1953-05	C CAPACITOR	0.10UF B		C841	CK73HB1E104K	C CAPACITOR	0.10UF K	
C745	C93-1959-05	C CAPACITOR	0.10UF B		C852	CK73HB1E104K	C CAPACITOR	0.10UF K	
C746	CK73GB0J106K	C CAPACITOR	10.0UF K		C853	CK73HB1H103K	C CAPACITOR	10000PF K	
C747	CK73GB0J106K	C CAPACITOR	10.0UF K		C854	CK73HBB1H102K	C CAPACITOR	1000PF K	
C748	CC73HCH1H100B	C CAPACITOR	10PF B		C856	CC73HCH1H470G	C CAPACITOR	47PF G	
C749	C93-1959-05	C CAPACITOR	0.10UF B		C857	CC73HCH1H470G	C CAPACITOR	47PF G	
C750	CK73GB0J106K	C CAPACITOR	10.0UF K		C862	CK73HBB1H472K	C CAPACITOR	0.047UF K	
C751	C93-1959-05	C CAPACITOR	0.10UF B		C898	CK73GB1H105K	C CAPACITOR	1.0UF K	
C752	C93-1959-05	C CAPACITOR	0.10UF B		C899	CK73GB0J106K	C CAPACITOR	10.0UF K	
C754	C93-1959-05	C CAPACITOR	0.10UF B		C900	CK73HB1H103K	C CAPACITOR	10000PF K	
C755	C93-1959-05	C CAPACITOR	0.10UF B		C901	CK73HB1E104K	C CAPACITOR	0.10UF K	
C756	C93-1959-05	C CAPACITOR	0.10UF B		C902	CK73HB1E104K	C CAPACITOR	0.10UF K	
C757	CK73HB1C105K	C CAPACITOR	1.0UF K		C903	CK73HBB1H102K	C CAPACITOR	1000PF K	
C758	C93-1959-05	C CAPACITOR	0.10UF B		C904	CK73HB1C105K	C CAPACITOR	1.0UF K	
C759	CC73JCH1H101J	C CAPACITOR	100PF J		C905	CK73HB1E104K	C CAPACITOR	0.10UF K	
C760	C93-1959-05	C CAPACITOR	0.10UF B		C906	CK73HB1C105K	C CAPACITOR	1.0UF K	
C762	C93-1959-05	C CAPACITOR	0.10UF B		C908	C93-1959-05	C CAPACITOR	0.10UF B	
C764	C93-1959-05	C CAPACITOR	0.10UF B		C909	CK73HB1C105K	C CAPACITOR	1.0UF K	
C766	C93-1959-05	C CAPACITOR	0.10UF B		C910	C93-1959-05	C CAPACITOR	0.10UF B	
C768	C93-1953-05	C CAPACITOR	0.10UF B		C911	C93-1959-05	C CAPACITOR	0.10UF B	
C769	CK73HB1C105K	C CAPACITOR	1.0UF K		C912	C93-1959-05	C CAPACITOR	0.10UF B	
C770	CK73HB1C105K	C CAPACITOR	1.0UF K		C913	C93-1959-05	C CAPACITOR	0.10UF B	
C771	C93-1959-05	C CAPACITOR	0.10UF B		C914	C93-1959-05	C CAPACITOR	0.10UF B	
C772	C93-1959-05	C CAPACITOR	0.10UF B		C915	CK73HB1E104K	C CAPACITOR	0.10UF K	
C773	C93-1959-05	C CAPACITOR	0.10UF B		C916	CK73GB0J106K	C CAPACITOR	10.0UF K	
C774	C93-1959-05	C CAPACITOR	0.10UF B		C917	CK73HB1C105K	C CAPACITOR	1.0UF K	
C775	C93-1959-05	C CAPACITOR	0.10UF B		C918	C93-1959-05	C CAPACITOR	0.10UF B	
C776	C93-1959-05	C CAPACITOR	0.10UF B		C919	CK73HB1C105K	C CAPACITOR	1.0UF K	
C777	C93-1959-05	C CAPACITOR	0.10UF B		C920	C93-1959-05	C CAPACITOR	0.10UF B	
C778	C93-1959-05	C CAPACITOR	0.10UF B		C921	CC73HCH1H101J	C CAPACITOR	100PF J	
C779	CK73HB1C105K	C CAPACITOR	1.0UF K		C922	CK73HBB1H472K	C CAPACITOR	0.047UF K	
C780	C93-1959-05	C CAPACITOR	0.10UF B		C924	CK73HB1C105K	C CAPACITOR	1.0UF K	
C781	CC73HCH1H150G	C CAPACITOR	15PF G		C925	CK73HB1C105K	C CAPACITOR	1.0UF K	
C782	CC73HCH1H150G	C CAPACITOR	15PF G		C926	CK73HB1C105K	C CAPACITOR	1.0UF K	
C783	CK73HB1E104K	C CAPACITOR	0.10UF K		C927	CK73HB1C105K	C CAPACITOR	1.0UF K	
C784	CK73HB1A224K	C CAPACITOR	0.22UF K		C928	CK73GB0J106K	C CAPACITOR	10.0UF K	
C785	CK73GB0J106K	C CAPACITOR	10.0UF K		C929	CK73HB1E104K	C CAPACITOR	0.10UF K	
C786	CK73GB0J106K	C CAPACITOR	10.0UF K		C930	CC73HCH1H680J	C CAPACITOR	68PF J	
C787	CK73HB1E104K	C CAPACITOR	0.10UF K		C931	CK73HB1A474K	C CAPACITOR	0.47UF K	
C791	C93-1959-05	C CAPACITOR	0.10UF B		C932	CK73GB0J106K	C CAPACITOR	10.0UF K	
C792	C93-1959-05	C CAPACITOR	0.10UF B		C933	CK73HB1H103K	C CAPACITOR	10000PF K	
C793	CK73HBB1H102K	C CAPACITOR	1000PF K		C934	CK73HB1H103K	C CAPACITOR	10000PF K	
C794	CK73HBB1H102K	C CAPACITOR	1000PF K		C935	CC73HCH1H101J	C CAPACITOR	100PF J	
C795	CK73HB1H103K	C CAPACITOR	10000PF K		C936	CK73GB0J106K	C CAPACITOR	10.0UF K	
C796	CK73HB1H103K	C CAPACITOR	10000PF K		C937	CK73GB1H105K	C CAPACITOR	1.0UF K	
C797	CK73HB1H103K	C CAPACITOR	10000PF K		C938	CK73HB1H103K	C CAPACITOR	10000PF K	
C798	CK73GB1H105K	C CAPACITOR	1.0UF K		C940	CK73HBB1H102K	C CAPACITOR	1000PF K	
C799	CK73HB1E104K	C CAPACITOR	0.10UF K		C941	CC73HCH1H101J	C CAPACITOR	100PF J	
C800	CK73HB1H103K	C CAPACITOR	10000PF K		C942	CK73HB1H103K	C CAPACITOR	10000PF K	
C801	CC73HCH1H101J	C CAPACITOR	100PF J		C943	CK73HB1E104K	C CAPACITOR	0.10UF K	
C802	CK73HB1C105K	C CAPACITOR	1.0UF K		C944	CK73GB1H105K	C CAPACITOR	1.0UF K	
C803	C93-1959-05	C CAPACITOR	0.10UF B		C945	CK73HB1H103K	C CAPACITOR	10000PF K	
C804	C93-1959-05	C CAPACITOR	0.10UF B		C946	CK73HB1H103K	C CAPACITOR	10000PF K	
C805	CC73HCH1H101J	C CAPACITOR	100PF J		C947	CK73HBB1H102K	C CAPACITOR	1000PF K	
C806	C93-1959-05	C CAPACITOR	0.10UF B		C948	CK73GB1H105K	C CAPACITOR	1.0UF K	
C807	CK73HB1H103K	C CAPACITOR	10000PF K		C949	CK73GB1H105K	C CAPACITOR	1.0UF K	
C808	CC73HCH1H101J	C CAPACITOR	100PF J		C950	CK73GB1H105K	C CAPACITOR	1.0UF K	
C809	CC73HCH1H101J	C CAPACITOR	100PF J		C951	CK73GB1H105K	C CAPACITOR	1.0UF K	
C810	CC73HCH1H101J	C CAPACITOR	100PF J		C952	CK73HBB1H102K	C CAPACITOR	1000PF K	
C811	C93-1959-05	C CAPACITOR	0.10UF B		C953	CC73HCH1H101J	C CAPACITOR	100PF J	
C812	CC73HCH1H101J	C CAPACITOR	100PF J		C954	CC73HCH1H101J	C CAPACITOR	100PF J	
C813	CC73HCH1H101J	C CAPACITOR	100PF J		C955	CC73HCH1H101J	C CAPACITOR	100PF J	

△ Symbol No.	Part No.	Part Name	Description	Local	△ Symbol No.	Part No.	Part Name	Description	Local
C956	CC73HCH1H101J	C CAPACITOR	100PF J		R44	RK73JB1H102J	MG RESISTOR	1.0K J 1/20W	
C957	CC73HCH1H101J	C CAPACITOR	100PF J		R45	RK73HH1J103D	MG RESISTOR	10K D 1/16W	
C958	CC73HCH1H101J	C CAPACITOR	100PF J		R46	RK73JB1H104J	MG RESISTOR	100K J 1/20W	
C959	CC73HCH1H101J	C CAPACITOR	100PF J		R47	RK73HB1J000J	MG RESISTOR	0.0 J 1/16W	
C960	CC73HCH1H101J	C CAPACITOR	100PF J		R48	RK73HH1J103D	MG RESISTOR	10K D 1/16W	
C961	CC73HCH1H101J	C CAPACITOR	100PF J		R49	RK73HH1J473D	MG RESISTOR	47K D 1/16W	
C962	CC73HCH1H101J	C CAPACITOR	100PF J		R50	RK73HH1J103D	MG RESISTOR	10K D 1/16W	
C963	CC73HCH1H101J	C CAPACITOR	100PF J		R51	RK73HB1J222J	MG RESISTOR	2.2K J 1/16W	
C964	CK73HB1E473K	C CAPACITOR	47000PF K		R52	RK73HB1J102J	MG RESISTOR	1.0K J 1/16W	
C965	CC73HCH1H101J	C CAPACITOR	100PF J		R53	RK73HB1J000J	MG RESISTOR	0.0 J 1/16W	
C966	CC73HCH1H101J	C CAPACITOR	100PF J		R54	R92-3769-05	METAL GLAZE RESISTOR		
C967	CK73HBB1H102K	C CAPACITOR	1000PF K		R55	R92-3769-05	METAL GLAZE RESISTOR		
C968	CC73HCH1H101J	C CAPACITOR	100PF J		R56	RK73HB1J334J	MG RESISTOR	330K J 1/16W	
C969	C92-0906-05	E CAPACITOR	330UF 16WV		R57	RK73HH1J223D	MG RESISTOR	22K D 1/16W	
C970	CK73HB1H103K	C CAPACITOR	10000PF K		R58	RK73HB1J102J	MG RESISTOR	1.0K J 1/16W	
C971	CE32BY1E470M	E CAPACITOR	47UF 25WV		R59	RK73HB1J100J	MG RESISTOR	10 J 1/16W	
C972	CK73HB1E104K	C CAPACITOR	0.10UF K		R60	RK73HB1J474J	MG RESISTOR	470K J 1/16W	
C973	CK73HB1E104K	C CAPACITOR	0.10UF K		R61	RK73HB1J102J	MG RESISTOR	1.0K J 1/16W	
C975	CC73HCH1H101J	C CAPACITOR	100PF J		R62	RK73HB1J102J	MG RESISTOR	1.0K J 1/16W	
C976	CC73HCH1H101J	C CAPACITOR	100PF J		R63	RK73HH1J273D	MG RESISTOR	27K D 1/16W	
C977	CK73HBB1H102K	C CAPACITOR	1000PF K		R64	RK73HH1J152D	MG RESISTOR	1.5K D 1/16W	
C978	CK73HBB1H471K	C CAPACITOR	470PF K		R65	RK73HH1J472D	MG RESISTOR	4.7K D 1/16W	
C979	CC73HCH1H101J	C CAPACITOR	100PF J		R66	RK73HH1J103D	MG RESISTOR	10K D 1/16W	
C980	CC73HCH1H101J	C CAPACITOR	100PF J		R67	RK73HH1J472D	MG RESISTOR	4.7K D 1/16W	
C981	CK73HBB1H102K	C CAPACITOR	1000PF K		R68	RK73HH1J103D	MG RESISTOR	10K D 1/16W	
C982	CC73HCH1H101J	C CAPACITOR	100PF J		R69	RK73HH1J472D	MG RESISTOR	4.7K D 1/16W	
C983	CC73HCH1H101J	C CAPACITOR	100PF J		R70	RK73HB1J000J	MG RESISTOR	0.0 J 1/16W	
C984	CC73HCH1H101J	C CAPACITOR	100PF J		R71	RK73HB1J331J	MG RESISTOR	330 J 1/16W	
C985	CC73HCH1H101J	C CAPACITOR	100PF J		R72	RK73JB1H473J	MG RESISTOR	47K J 1/20W	
C986	CC73HCH1H101J	C CAPACITOR	100PF J		R73	RK73HB1J471J	MG RESISTOR	470 J 1/16W	
C987	CC73HCH1H101J	C CAPACITOR	100PF J		R75	RK73HB1J474J	MG RESISTOR	470K J 1/16W	
C988	CC73HCH1H101J	C CAPACITOR	100PF J		R76	RK73FB2B332J	MG RESISTOR	3.3K J 1/8W	
C989	CC73HCH1H101J	C CAPACITOR	100PF J		R77	RK73FB2B332J	MG RESISTOR	3.3K J 1/8W	
C990	CC73HCH1H101J	C CAPACITOR	100PF J		R78	RK73FB2B332J	MG RESISTOR	3.3K J 1/8W	
C991	CC73HCH1H101J	C CAPACITOR	100PF J		R84	RK73HB1J000J	MG RESISTOR	0.0 J 1/16W	
C992	CC73HCH1H101J	C CAPACITOR	100PF J		R96	RK73FB2B2R7J	MG RESISTOR	2.7 J 1/16W	
C993	CC73HCH1H101J	C CAPACITOR	100PF J		R97	RK73FB2B3R3J	MG RESISTOR	3.3 J 1/16W	
C994	CC73HCH1H101J	C CAPACITOR	100PF J		R100	RK73HB1J122J	MG RESISTOR	1.2 J 1/20W	
C995	CC73HCH1H101J	C CAPACITOR	100PF J		R101	RK73HB1J100J	MG RESISTOR	10 J 1/16W	
C996	CC73HCH1H101J	C CAPACITOR	100PF J		R102	RK73HB1J000J	MG RESISTOR	0.0 J 1/16W	
C997	CK73HBB1H102K	C CAPACITOR	1000PF K		R103	RK73HB1J100J	MG RESISTOR	10 J 1/16W	
C998	CK73HBB1H102K	C CAPACITOR	1000PF K		R104	RK73HB1J100J	MG RESISTOR	10 J 1/16W	
C999	CK73HB1C105K	C CAPACITOR	1.0UF K		R106	RK73HH1J473D	MG RESISTOR	47K D 1/16W	
					R107	RK73HB1J102J	MG RESISTOR	1.0K J 1/16W	
R8	RK73HH1J104D	MG RESISTOR	100K D 1/16W		R108	RK73HB1J102J	MG RESISTOR	1.0K J 1/16W	
R10	RK73HH1J104D	MG RESISTOR	100K D 1/16W		R109	RK73HB1J470J	MG RESISTOR	47 J 1/16W	
R11	RK73HH1J104D	MG RESISTOR	100K D 1/16W		R110	RK73HB1J102J	MG RESISTOR	1.0K J 1/16W	
R12	RK73HB1J000J	MG RESISTOR	0.0 J 1/16W		R111	RK73HH1J223D	MG RESISTOR	22K D 1/16W	
R13	RK73HH1J104D	MG RESISTOR	100K D 1/16W		R112	RK73HB1J000J	MG RESISTOR	0.0 J 1/16W	
R14	RK73HH1J223D	MG RESISTOR	22K D 1/16W		R113	RK73HB1J124J	MG RESISTOR	120K J 1/16W	
R15	RK73HH1J103D	MG RESISTOR	10K D 1/16W		R115	RK73HB1J000J	MG RESISTOR	0.0 J 1/16W	
R16	RK73JB1H102J	MG RESISTOR	1.0K J 1/20W		R116	RK73HB1J000J	MG RESISTOR	0.0 J 1/16W	
R17	RK73HH1J103D	MG RESISTOR	10K D 1/16W		R117	RK73HB1J000J	MG RESISTOR	0.0 J 1/16W	
R18	RK73JB1H104J	MG RESISTOR	100K J 1/20W		R118	RK73HB1J222J	MG RESISTOR	2.2K J 1/16W	
R19	RK73HH1J473D	MG RESISTOR	47K D 1/16W		R121	RK73HB1J151J	MG RESISTOR	150 J 1/16W	
R20	RK73GB2A000J	MG RESISTOR	0.0 J 1/10W		R122	RK73HH1J472D	MG RESISTOR	4.7K D 1/16W	
R21	RK73HH1J104D	MG RESISTOR	100K D 1/16W		R123	RK73HH1J104D	MG RESISTOR	100K D 1/16W	
R22	RK73JB1H103J	MG RESISTOR	10K J 1/20W		R124	RK73HH1J391D	MG RESISTOR	390 D 1/16W	
R23	RK73JB1H102J	MG RESISTOR	1.0K J 1/20W		R125	RK73HH1J103D	MG RESISTOR	10K D 1/16W	
R24	RK73JB1H104J	MG RESISTOR	100K J 1/20W		R126	RK73HB1J106J	MG RESISTOR	10M J 1/16W	
R25	RK73JB1H472J	MG RESISTOR	4.7K J 1/20W		R127	RK73HH1J104D	MG RESISTOR	100K D 1/16W	
R26	RK73JB1H102J	MG RESISTOR	1.0K J 1/20W		R128	RK73HB1J470J	MG RESISTOR	47 J 1/16W	
R27	RK73JB1H103J	MG RESISTOR	10K J 1/20W		R129	RK73HH1J104D	MG RESISTOR	100K D 1/16W	
R29	RK73JB1H473J	MG RESISTOR	47K J 1/20W		R130	RN73HH1J151D	MG RESISTOR	150 D 1/16W	
R30	RK73HH1J223D	MG RESISTOR	22K D 1/16W		R131	RN73HH1J100D	MG RESISTOR	10 D 1/16W	
R31	RK73HB1J000J	MG RESISTOR	0.0 J 1/16W		R132	RK73HB1J000J	MG RESISTOR	0.0 J 1/16W	
R32	RK73HB1J101J	MG RESISTOR	100 J 1/16W		R133	RN73H0AJ181D	MF RESISTOR	180 J 1/16W	
R33	RK73HH1J103D	MG RESISTOR	10K D 1/16W		R134	RN73HH1J100D	MG RESISTOR	10 D 1/16W	
R34	RK73HH1J333D	MG RESISTOR	33K D 1/16W		R135	RK73HB1J000J	MG RESISTOR	0.0 J 1/16W	
R35	RK73HH1J103D	MG RESISTOR	10K D 1/16W		R136	RK73HB1J392J	MG RESISTOR	3.9K J 1/16W	
R36	RK73HH1J103D	MG RESISTOR	10K D 1/16W		R137	RK73HB1J272J	MG RESISTOR	2.7K J 1/16W	
R37	RK73HB1J101J	MG RESISTOR	100 J 1/16W		R138	RK73HB1J820J	MG RESISTOR	82 J 1/16W	
R38	RK73HB1J224J	MG RESISTOR	220K J 1/16W		R139	RK73HB1J330J	MG RESISTOR	33 J 1/16W	
R39	RK73HH1J104D	MG RESISTOR	100K D 1/16W		R140	RK73HB1J222J	MG RESISTOR	2.2K J 1/16W	
R40	RK73JB1H104J	MG RESISTOR	100K J 1/20W		R141	RK73HH1J562D	MG RESISTOR	5.6K D 1/16W	
R41	RK73JB1H104J	MG RESISTOR	100K J 1/20W		R142	RK73HB1J150J	MG RESISTOR	15 J 1/16W	
R42	RK73JB1H473J	MG RESISTOR	47K J 1/20W		R143	RK73HB1J101J	MG RESISTOR	100 J 1/16W	
R43	RK73HB1J000J	MG RESISTOR	0.0 J 1/16W		R144	RK73HH1J562D	MG RESISTOR	5.6K D 1/16W	

△ Symbol No.	Part No.	Part Name	Description	Local	△ Symbol No.	Part No.	Part Name	Description	Local
R145	RK73HH1J332D	MG RESISTOR	3.3K D 1/16W		R355	RK73HB1J271J	MG RESISTOR	270 J 1/16W	
R146	RK73HB1J101J	MG RESISTOR	100 J 1/16W		R359	RK73GB2A000J	MG RESISTOR	0.0 J 1/10W	
R147	RK73HB1J221J	MG RESISTOR	220 J 1/16W		R360	RK73GB2A000J	MG RESISTOR	0.0 J 1/10W	
R148	RK73HB1J330J	MG RESISTOR	33 J 1/16W		R361	RK73F0GZ3R3F	MG RESISTOR	3.3 F 1/3W	
R149	RK73HB1J474J	MG RESISTOR	470K J 1/16W		R362	RK73F0GZ3R3F	MG RESISTOR	3.3 F 1/3W	
R151	RK73HB1J183J	MG RESISTOR	18K J 1/16W		R369	RK73GB2A470J	MG RESISTOR	47 J 1/10W	
R152	RK73HH1J473D	MG RESISTOR	47K D 1/16W		R371	RK73HB1J000J	MG RESISTOR	0.0 J 1/16W	
R153	RK73HH1J473D	MG RESISTOR	47K D 1/16W		R373	RK73HB1J682J	MG RESISTOR	6.8K J 1/16W	
R154	RK73HH1J103D	MG RESISTOR	10K D 1/16W		R374	RK73HH1J223D	MG RESISTOR	22K D 1/16W	
R155	RK73HB1J000J	MG RESISTOR	0.0 J 1/16W		R375	RK73HB1J821J	MG RESISTOR	820 J 1/16W	
R156	RK73HB1J000J	MG RESISTOR	0.0 J 1/16W		R376	RK73HB1J181J	MG RESISTOR	180 J 1/16W	
R158	RK73HB1J000J	MG RESISTOR	0.0 J 1/16W		R380	RK73HB1J222J	MG RESISTOR	2.2K J 1/16W	
R159	RK73HB1J474J	MG RESISTOR	470K J 1/16W		R381	RK73HB1J222J	MG RESISTOR	2.2K J 1/16W	
R160	RK73HB1J392J	MG RESISTOR	3.9K J 1/16W		R382	RK73HH1J223D	MG RESISTOR	22K D 1/16W	
R161	RK73HB1J474J	MG RESISTOR	470K J 1/16W		R383	RK73HH1J223D	MG RESISTOR	22K D 1/16W	
R162	RK73HB1J121J	MG RESISTOR	120 J 1/16W		R384	RK73HH1J103D	MG RESISTOR	10K D 1/16W	
R166	RK73HB1J102J	MG RESISTOR	1.0K J 1/16W		R385	RK73HB1J470J	MG RESISTOR	47 J 1/16W	
R170	RK73HH1J473D	MG RESISTOR	47K D 1/16W		R386	RK73HB1J470J	MG RESISTOR	47 J 1/16W	
R171	RK73HB1J474J	MG RESISTOR	470K J 1/16W		R387	RK73HB1J822J	MG RESISTOR	8.2K J 1/16W	
R172	RK73HB1J102J	MG RESISTOR	1.0K J 1/16W		R388	RK73HB1J393J	MG RESISTOR	39K J 1/16W	
R173	RK73HH1J472D	MG RESISTOR	4.7K D 1/16W		R389	RK73HB1J000J	MG RESISTOR	0.0 J 1/16W	
R174	RK73HB1J181J	MG RESISTOR	180 J 1/16W		R391	RK73HB1J101J	MG RESISTOR	100 J 1/16W	
R175	RK73HB1J330J	MG RESISTOR	33 J 1/16W		R392	RK73HH1J103D	MG RESISTOR	10K D 1/16W	
R176	RK73HB1J181J	MG RESISTOR	180 J 1/16W		R395	RK73HB1J470J	MG RESISTOR	47 J 1/16W	
R177	RK73HB1J331J	MG RESISTOR	330 J 1/16W		R397	RK73HB1J000J	MG RESISTOR	0.0 J 1/16W	
R178	RK73HB1J150J	MG RESISTOR	15 J 1/16W		R398	RK73HH1J223D	MG RESISTOR	22K D 1/16W	
R179	RK73HB1J331J	MG RESISTOR	330 J 1/16W		R399	RK73HB1J222J	MG RESISTOR	2.2K J 1/16W	
R300	RK73HH1J332D	MG RESISTOR	3.3K D 1/16W		R401	RK73HH1J122D	MG RESISTOR	1.2K D 1/16W	
R301	RK73HB1J331J	MG RESISTOR	330 J 1/16W		R402	R92-1061-05	JUMPER REST	0 OHM	
R302	RK73HB1J150J	MG RESISTOR	15 J 1/16W		R403	RK73HH1J223D	MG RESISTOR	22K D 1/16W	
R303	RK73HB1J331J	MG RESISTOR	330 J 1/16W		R404	RK73HB1J182J	MG RESISTOR	1.8K J 1/16W	
R304	RK73HB1J000J	MG RESISTOR	0.0 J 1/16W		R405	RK73HH1J223D	MG RESISTOR	22K D 1/16W	
R305	RK73HB1J821J	MG RESISTOR	820 J 1/16W		R406	RK73HH1J223D	MG RESISTOR	22K D 1/16W	
R306	RK73HB1J101J	MG RESISTOR	100 J 1/16W		R407	RK73HB1J000J	MG RESISTOR	0.0 J 1/16W	
R307	RK73HB1J682J	MG RESISTOR	6.8K J 1/16W		R408	RK73HH1J223D	MG RESISTOR	22K D 1/16W	
R308	RK73HB1J271J	MG RESISTOR	270 J 1/16W		R409	RK73HH1J223D	MG RESISTOR	22K D 1/16W	
R309	RK73HB1J180J	MG RESISTOR	18 J 1/16W		R411	RK73HH1J223D	MG RESISTOR	22K D 1/16W	
R310	RK73HB1J271J	MG RESISTOR	270 J 1/16W		R412	RK73HH1J104D	MG RESISTOR	100K D 1/16W	
R311	RK73HH1J562D	MG RESISTOR	5.6K J 1/16W		R413	RK73HB1J471J	MG RESISTOR	470 J 1/16W	
R312	RK73HB1J470J	MG RESISTOR	47 J 1/16W		R414	RK73HH1J223D	MG RESISTOR	22K D 1/16W	
R313	RK73HB1J822J	MG RESISTOR	8.2K J 1/16W		R415	RK73HH1J104D	MG RESISTOR	100K D 1/16W	
R314	RK73HB1J471J	MG RESISTOR	470 J 1/16W		R416	RK73HH1J103D	MG RESISTOR	10K D 1/16W	
R315	RK73EB2E271J	MG RESISTOR	270 J 1/16W		R417	RK73HH1J223D	MG RESISTOR	22K D 1/16W	
R316	RK73EB2E180J	MG RESISTOR	18 J 1/16W		R418	RK73HH1J223D	MG RESISTOR	22K D 1/16W	
R317	RK73EB2E271J	MG RESISTOR	270 J 1/16W		R420	RK73HH1J104D	MG RESISTOR	100K D 1/16W	
R318	RK73GB2A470J	MG RESISTOR	47 J 1/16W		R421	RK73HH1J104D	MG RESISTOR	100K D 1/16W	
R319	RK73HB1J822J	MG RESISTOR	8.2K J 1/16W		R422	RK73HH1J103D	MG RESISTOR	10K D 1/16W	
R320	RK73HH1J562D	MG RESISTOR	5.6K D 1/16W		R423	RK73HB1J222J	MG RESISTOR	2.2K J 1/16W	
R321	RK73FB2B471J	MG RESISTOR	470 J 1/8W		R424	RK73HB1J000J	MG RESISTOR	0.0 J 1/16W	
R323	RK73GB2A332J	MG RESISTOR	3.3K J 1/10W		R426	RK73HB1J000J	MG RESISTOR	0.0 J 1/16W	
R324	RK73GB2A470J	MG RESISTOR	47 J 1/10W		R427	RK73HH1J223D	MG RESISTOR	22K D 1/16W	
R325	RK73GB2A562J	MG RESISTOR	5.6K J 1/10W		R428	RK73HB1J183J	MG RESISTOR	18K J 1/16W	
R327	RK73GB2A103J	MG RESISTOR	10K J 1/10W		R429	RK73HB1J822J	MG RESISTOR	8.2K J 1/16W	
R328	RK73GB2A103J	MG RESISTOR	10K J 1/10W		R431	RK73HH1J223D	MG RESISTOR	22K D 1/16W	
R329	RK73GB2A103J	MG RESISTOR	10K J 1/10W		R432	RK73HH1J103D	MG RESISTOR	10K D 1/16W	
R330	RK73GB2A103J	MG RESISTOR	10K J 1/10W		R433	RK73HB1J682J	MG RESISTOR	6.8K J 1/16W	
R331	RK73PB2H471J	MG RESISTOR	470 J 1/2W		R434	RK73HH1J472D	MG RESISTOR	4.7K D 1/16W	
R332	RK73PB2H471J	MG RESISTOR	470 J 1/2W		R436	RK73HH1J473D	MG RESISTOR	47K D 1/16W	
R333	RK73F0GZ1R0F	MG RESISTOR	1.0 F 1/3W		R437	RK73HB1J822J	MG RESISTOR	8.2K J 1/16W	
R334	RK73HH1J103D	MG RESISTOR	10K D 1/16W		R438	RK73HB1J822J	MG RESISTOR	8.2K J 1/16W	
R335	RK73F0GZ1R0F	MG RESISTOR	1.0 F 1/3W		R500	RK73HB1J331J	MG RESISTOR	330 J 1/16W	
R336	RK73FB2B3R3J	MG RESISTOR	3.3 J 1/16W		R501	RK73HB1J180J	MG RESISTOR	18 J 1/16W	
R337	RK73F0GZ3R3F	MG RESISTOR	3.3 F 1/3W		R502	RK73HB1J331J	MG RESISTOR	330 J 1/16W	
R338	RK73F0GZ3R3F	MG RESISTOR	3.3 F 1/3W		R503	RK73HH1J103D	MG RESISTOR	10K D 1/16W	
R339	RK73RB2H5R6J	MG RESISTOR	56 J 1/16W		R504	RK73HH1J103D	MG RESISTOR	10K D 1/16W	
R340	RK73GB2A680J	MG RESISTOR	68 J 1/10W		R505	RK73HB1J271J	MG RESISTOR	270 J 1/16W	
R341	RK73GB2A181J	MG RESISTOR	180 J 1/10W		R506	RK73HB1J470J	MG RESISTOR	47 J 1/16W	
R342	RK73GB2A680J	MG RESISTOR	68 J 1/10W		R507	RK73HB1J222J	MG RESISTOR	2.2K J 1/16W	
R343	RK73HB1J000J	MG RESISTOR	0.0 J 1/16W		R508	RK73HH1J472D	MG RESISTOR	4.7K D 1/16W	
R344	RK73FB2B121J	MG RESISTOR	120 J 1/16W		R509	RK73HB1J222J	MG RESISTOR	2.2K J 1/16W	
R346	RK73HH1J333D	MG RESISTOR	33K D 1/16W		R510	RK73HH1J273D	MG RESISTOR	27K D 1/16W	
R347	RK73HH1J103D	MG RESISTOR	10K D 1/16W		R511	RK73HB1J000J	MG RESISTOR	0.0 J 1/16W	
R348	RK73HB1J000J	MG RESISTOR	0.0 J 1/16W		R512	RK73HB1J000J	MG RESISTOR	0.0 J 1/16W	
R349	RK73GB2A000J	MG RESISTOR	0.0 J 1/10W		R514	RK73HB1J101J	MG RESISTOR	100 J 1/16W	
R350	RK73FB2B101J	MG RESISTOR	100 J 1/16W		R515	RK73HB1J000J	MG RESISTOR	0.0 J 1/16W	
R351	RK73GB2A470J	MG RESISTOR	47 J 1/10W		R516	RK73HB1J101J	MG RESISTOR	100 J 1/16W	
R353	RK73PB2H470J	MG RESISTOR	47 J 1/2W		R518	RK73HH1J223D	MG RESISTOR	22K D 1/16W	
R354	RK73PB2H470J	MG RESISTOR	47 J 1/2W		R519	RK73HH1J223D	MG RESISTOR	22K D 1/16W	

△ Symbol No.	Part No.	Part Name	Description	Local	△ Symbol No.	Part No.	Part Name	Description	Local
R520	RK73HH1J223D	MG RESISTOR	22K D 1/16W		R742	RK73HB1J102J	MG RESISTOR	1.0K J 1/16W	
R521	RK73HH1J223D	MG RESISTOR	22K D 1/16W		R744	RK73HB1J102J	MG RESISTOR	1.0K J 1/16W	
R527	RK73HB1J000J	MG RESISTOR	0.0 J 1/16W		R746	RK73HB1J102J	MG RESISTOR	1.0K J 1/16W	
R528	RK73HB1J000J	MG RESISTOR	0.0 J 1/16W		R747	RK73JB1H220J	MG RESISTOR	22 J 1/20W	
R531	RK73HB1J474J	MG RESISTOR	470K J 1/16W		R748	RK73JB1H220J	MG RESISTOR	22 J 1/20W	
R532	RK73HB1J474J	MG RESISTOR	470K J 1/16W		R749	RK73JB1H220J	MG RESISTOR	22 J 1/20W	
R533	RK73HB1J474J	MG RESISTOR	470K J 1/16W		R750	RK73JB1H220J	MG RESISTOR	22 J 1/20W	
R534	RK73HB1J474J	MG RESISTOR	470K J 1/16W		R751	RK73JB1H220J	MG RESISTOR	22 J 1/20W	
R537	RK73HB1J470J	MG RESISTOR	47 J 1/16W		R752	RK73HH1J332D	MG RESISTOR	3.3K D 1/16W	
R538	RK73HB1J101J	MG RESISTOR	100 J 1/16W		R753	RK73JB1H220J	MG RESISTOR	22 J 1/20W	
R539	RK73HB1J000J	MG RESISTOR	0.0 J 1/16W		R754	RK73JB1H220J	MG RESISTOR	22 J 1/20W	
R540	RK73HB1J000J	MG RESISTOR	0.0 J 1/16W		R755	RK73JB1H104J	MG RESISTOR	100K J 1/20W	
R541	RK73HB1J183J	MG RESISTOR	18K J 1/16W		R756	RK73JB1H104J	MG RESISTOR	100K J 1/20W	
R542	RK73HB1J183J	MG RESISTOR	18K J 1/16W		R757	RK73JB1H220J	MG RESISTOR	22 J 1/20W	
R543	RK73HB1J183J	MG RESISTOR	18K J 1/16W		R758	RK73JB1H220J	MG RESISTOR	22 J 1/20W	
R544	RK73HB1J183J	MG RESISTOR	18K J 1/16W		R759	RK73JB1H220J	MG RESISTOR	22 J 1/20W	
R545	RK73HB1J331J	MG RESISTOR	330 J 1/16W		R760	RK73JB1H220J	MG RESISTOR	22 J 1/20W	
R546	RK73HB1J180J	MG RESISTOR	18 J 1/16W		R761	RK73JB1H220J	MG RESISTOR	22 J 1/20W	
R547	RK73HB1J474J	MG RESISTOR	470K J 1/16W		R762	RK73JB1H220J	MG RESISTOR	22 J 1/20W	
R548	RK73HB1J474J	MG RESISTOR	470K J 1/16W		R763	RK73JB1H220J	MG RESISTOR	22 J 1/20W	
R549	RK73HB1J474J	MG RESISTOR	470K J 1/16W		R764	RK73JB1H104J	MG RESISTOR	100K J 1/20W	
R550	RK73HB1J474J	MG RESISTOR	470K J 1/16W		R765	RK73JB1H220J	MG RESISTOR	22 J 1/20W	
R554	RK73HB1J474J	MG RESISTOR	470K J 1/16W		R766	RK73JB1H220J	MG RESISTOR	22 J 1/20W	
R555	RK73HB1J474J	MG RESISTOR	470K J 1/16W		R767	RK73JB1H220J	MG RESISTOR	22 J 1/20W	
R556	RK73HB1J474J	MG RESISTOR	470K J 1/16W		R768	RK73JB1H220J	MG RESISTOR	22 J 1/20W	
R557	RK73HB1J331J	MG RESISTOR	330 J 1/16W		R770	RK73JB1H220J	MG RESISTOR	22 J 1/20W	
R600	RK73HB1J100J	MG RESISTOR	10 J 1/16W		R772	RK73JB1H220J	MG RESISTOR	22 J 1/20W	
R601	RK73HB1J100J	MG RESISTOR	10 J 1/16W		R773	RK73JB1H104J	MG RESISTOR	100K J 1/20W	
R602	RK73HB1J100J	MG RESISTOR	10 J 1/16W		R774	RK73JB1H220J	MG RESISTOR	22 J 1/20W	
R603	RK73HB1J102J	MG RESISTOR	1.0K J 1/16W		R775	RK73JB1H220J	MG RESISTOR	22 J 1/20W	
R604	RK73HB1J681J	MG RESISTOR	680 J 1/16W		R777	RK73JB1H102J	MG RESISTOR	1.0K J 1/20W	
R605	RK73JB1H103J	MG RESISTOR	10K J 1/20W		R778	RK73JB1H220J	MG RESISTOR	22 J 1/20W	
R606	RK73HB1J000J	MG RESISTOR	0.0 J 1/16W		R779	RK73JB1H220J	MG RESISTOR	22 J 1/20W	
R607	RK73HB1J220J	MG RESISTOR	22 J 1/16W		R781	RK73JB1H220J	MG RESISTOR	22 J 1/20W	
R608	RK73HH1J391D	MG RESISTOR	390 D 1/16W		R782	RK73JB1H220J	MG RESISTOR	22 J 1/20W	
R609	RK73HB1J182J	MG RESISTOR	1.8K J 1/16W		R783	RK73JB1H220J	MG RESISTOR	22 J 1/20W	
R610	RK73HH1J562D	MG RESISTOR	5.6K D 1/16W		R785	RK73JB1H220J	MG RESISTOR	22 J 1/20W	
R611	RK73HB1J471J	MG RESISTOR	470 J 1/16W		R787	RK73JB1H220J	MG RESISTOR	22 J 1/20W	
R612	RK73JB1H472J	MG RESISTOR	4.7K J 1/20W		R788	RK73JB1H220J	MG RESISTOR	22 J 1/20W	
R613	RK73HH1J104D	MG RESISTOR	100K D 1/16W		R789	RK73HB1J101J	MG RESISTOR	100 J 1/16W	
R614	RK73HB1J470J	MG RESISTOR	47 J 1/16W		R790	RK73JB1H220J	MG RESISTOR	22 J 1/20W	
R615	RK73HH1J103D	MG RESISTOR	10K D 1/16W		R791	RK73JB1H220J	MG RESISTOR	22 J 1/20W	
R616	RK73HB1J101J	MG RESISTOR	100 J 1/16W		R792	RK73JB1H220J	MG RESISTOR	22 J 1/20W	
R617	RK73HB1J274J	MG RESISTOR	270K J 1/16W		R794	RK73JB1H220J	MG RESISTOR	22 J 1/20W	
R618	RK73HB1J271J	MG RESISTOR	270 J 1/16W		R795	RK73JB1H220J	MG RESISTOR	22 J 1/20W	
R619	RK73HB1J180J	MG RESISTOR	18 J 1/16W		R797	RK73JB1H220J	MG RESISTOR	22 J 1/20W	
R620	RK73HB1J271J	MG RESISTOR	270 J 1/16W		R798	RK73JB1H220J	MG RESISTOR	22 J 1/20W	
R621	RK73HB1J470J	MG RESISTOR	47 J 1/16W		R799	RK73JB1H220J	MG RESISTOR	22 J 1/20W	
R622	RK73HB1J681J	MG RESISTOR	680 J 1/16W		R800	RK73JB1H220J	MG RESISTOR	22 J 1/20W	
R623	RK73HH1J104D	MG RESISTOR	100K D 1/16W		R801	RK73JB1H220J	MG RESISTOR	22 J 1/20W	
R624	RK73HB1J563J	MG RESISTOR	56K J 1/16W		R802	RK73JB1H220J	MG RESISTOR	22 J 1/20W	
R625	RK73HB1J823J	MG RESISTOR	82K J 1/16W		R803	RK73JB1H220J	MG RESISTOR	22 J 1/20W	
R626	RK73HH1J333D	MG RESISTOR	33K D 1/16W		R804	RK73JB1H220J	MG RESISTOR	22 J 1/20W	
R628	RK73HB1J101J	MG RESISTOR	100 J 1/16W		R805	RK73GH2A49R9D	MG RESISTOR	49.9 D 1/10W	
R630	RK73HB1J000J	MG RESISTOR	0.0 J 1/16W		R806	RK73JB1H220J	MG RESISTOR	22 J 1/20W	
R631	RK73HB1J000J	MG RESISTOR	0.0 J 1/16W		R807	RK73JB1H102J	MG RESISTOR	1.0K J 1/20W	
R632	RK73GB2A000J	MG RESISTOR	0.0 J 1/10W		R808	RK73JB1H102J	MG RESISTOR	1.0K J 1/20W	
R700	RK73HB1J102J	MG RESISTOR	1.0K J 1/16W		R809	RK73JB1H220J	MG RESISTOR	22 J 1/20W	
R701	RK73HB1J000J	MG RESISTOR	0.0 J 1/16W		R810	RK73JB1H102J	MG RESISTOR	1.0K J 1/20W	
R702	RK73HB1J100J	MG RESISTOR	10 J 1/16W		R812	RK73JB1H222J	MG RESISTOR	2.2K J 1/20W	
R707	RK73HB1J100J	MG RESISTOR	10 J 1/16W		R813	RK73JB1H220J	MG RESISTOR	22 J 1/20W	
R708	RK73HB1J220J	MG RESISTOR	22 J 1/16W		R814	RK73JB1H220J	MG RESISTOR	22 J 1/20W	
R709	RK73HB1J102J	MG RESISTOR	1.0K J 1/16W		R815	RK73JB1H220J	MG RESISTOR	22 J 1/20W	
R719	RK73HB1J153J	MG RESISTOR	15K J 1/16W		R816	RK73HB1J102J	MG RESISTOR	1.0K J 1/16W	
R720	RK73HH1J333D	MG RESISTOR	33K D 1/16W		R817	RK73JB1H220J	MG RESISTOR	22 J 1/20W	
R721	RK73HB1J100J	MG RESISTOR	10 J 1/16W		R828	RK73HH1J103D	MG RESISTOR	10K D 1/16W	
R722	RK73HB1J681J	MG RESISTOR	680 J 1/16W		R830	RK73JB1H103J	MG RESISTOR	10K J 1/20W	
R727	RK73HB1J821J	MG RESISTOR	820 J 1/16W		R831	RK73HB1J102J	MG RESISTOR	1.0K J 1/16W	
R728	RK73JB1H104J	MG RESISTOR	100K J 1/20W		R833	RK73JB1H104J	MG RESISTOR	100K J 1/20W	
R729	RK73JB1H104J	MG RESISTOR	100K J 1/20W		R835	RK73JB1H104J	MG RESISTOR	100K J 1/20W	
R731	RK73JB1H473J	MG RESISTOR	47K J 1/20W		R837	RK73HB1J102J	MG RESISTOR	1.0K J 1/16W	
R732	RK73JB1H472J	MG RESISTOR	4.7K J 1/20W		R838	RK73HB1J000J	MG RESISTOR	0.0 J 1/16W	
R733	RK73HB1J000J	MG RESISTOR	0.0 J 1/16W		R839	RK73HH1J473D	MG RESISTOR	47K D 1/16W	
R734	RK73JB1H103J	MG RESISTOR	10K J 1/20W		R843	RK73HH1J104D	MG RESISTOR	100K D 1/16W	
R735	RK73JB1H103J	MG RESISTOR	10K J 1/20W		R844	RK73HH1J103D	MG RESISTOR	10K D 1/16W	
R736	RK73HB1J000J	MG RESISTOR	0.0 J 1/16W		R845	RK73HH1J103D	MG RESISTOR	10K D 1/16W	
R738	RK73HB1J102J	MG RESISTOR	1.0K J 1/16W		R854	RK73HB1J000J	MG RESISTOR	0.0 J 1/16W	
R740	RK73HB1J102J	MG RESISTOR	1.0K J 1/16W		R857	RK73HH1J333D	MG RESISTOR	33K D 1/16W	

△ Symbol No.	Part No.	Part Name	Description	Local	△ Symbol No.	Part No.	Part Name	Description	Local
R858	RK73HH1J223D	MG RESISTOR	22K D 1/16W		R966	RK73HB1J471J	MG RESISTOR	470 J 1/16W	
R859	RK73HH1J223D	MG RESISTOR	22K D 1/16W		R967	RK73GB2A221J	MG RESISTOR	220 J 1/10W	
R862	RK73HB1J222J	MG RESISTOR	2.2K J 1/16W		R968	RK73GB2A221J	MG RESISTOR	220 J 1/10W	
R863	RK73HB1J000J	MG RESISTOR	0.0 J 1/16W		R969	RK73HB1J471J	MG RESISTOR	470 J 1/16W	
R864	RK73HB1J000J	MG RESISTOR	0.0 J 1/16W		R970	RK73HB1J101J	MG RESISTOR	100 J 1/16W	
R865	RK73HB1J222J	MG RESISTOR	2.2K J 1/16W		R971	RK73HB1J471J	MG RESISTOR	470 J 1/16W	
R867	RK73HH1J823D	MG RESISTOR	82K D 1/16W		R972	RK73HB1J471J	MG RESISTOR	470 J 1/16W	
R868	RK73HB1J000J	MG RESISTOR	0.0 J 1/16W		R973	RK73HB1J471J	MG RESISTOR	470 J 1/16W	
R869	RK73HB1J000J	MG RESISTOR	0.0 J 1/16W		R974	RK73HB1J101J	MG RESISTOR	100 J 1/16W	
R874	RK73JB1H104J	MG RESISTOR	100K J 1/20W		R975	RK73HB1J101J	MG RESISTOR	100 J 1/16W	
R876	RK73HB1J102J	MG RESISTOR	1.0K J 1/16W		R976	RK73HB1J101J	MG RESISTOR	100 J 1/16W	
R877	RK73FB2B332J	MG RESISTOR	3.3K J 1/8W		R977	RK73GB2A102J	MG RESISTOR	1.0K J 1/10W	
R878	RK73FB2B332J	MG RESISTOR	3.3K J 1/8W		R978	RK73HH1J473D	MG RESISTOR	47K D 1/16W	
R879	RK73FB2B332J	MG RESISTOR	3.3K J 1/8W		R979	RK73HB1J681J	MG RESISTOR	680 J 1/16W	
R880	RK73HB1J102J	MG RESISTOR	1.0K J 1/16W		R980	RK73HB1J000J	MG RESISTOR	0.0 J 1/16W	
R881	RK73HB1J331J	MG RESISTOR	330 J 1/16W		R981	RK73GB2A221J	MG RESISTOR	220 J 1/10W	
R882	RK73JB1H473J	MG RESISTOR	47K J 1/20W		R982	RK73GB2A221J	MG RESISTOR	220 J 1/10W	
R883	RK73JB1H473J	MG RESISTOR	47K J 1/20W		R983	RK73HB1J101J	MG RESISTOR	100 J 1/16W	
R884	RK73HH1J104D	MG RESISTOR	100K D 1/16W		R984	RK73HB1J682J	MG RESISTOR	6.8K J 1/16W	
R885	RK73HB1J000J	MG RESISTOR	0.0 J 1/16W		R985	RK73HH1J104D	MG RESISTOR	100K D 1/16W	
R900	RK73HB1J100J	MG RESISTOR	10 J 1/16W		R991	RK73HB1J000J	MG RESISTOR	0.0 J 1/16W	
R901	RK73HB1J101J	MG RESISTOR	100 J 1/16W		R992	RK73HB1J102J	MG RESISTOR	1.0K J 1/16W	
R902	RK73HB1J100J	MG RESISTOR	10 J 1/16W		R993	RK73HB1J000J	MG RESISTOR	0.0 J 1/16W	
R903	RK73HH1J103D	MG RESISTOR	10K D 1/16W		R994	RK73HB1J000J	MG RESISTOR	0.0 J 1/16W	
R904	RK73HH1J223D	MG RESISTOR	22K D 1/16W		R996	RK73HB1J000J	MG RESISTOR	0.0 J 1/16W	
R905	RK73HH1J223D	MG RESISTOR	22K D 1/16W		R997	RK73HB1J000J	MG RESISTOR	0.0 J 1/16W	
R906	RK73HB1J000J	MG RESISTOR	0.0 J 1/16W		R998	RK73HB1J000J	MG RESISTOR	0.0 J 1/16W	
R907	RK73HB1J000J	MG RESISTOR	0.0 J 1/16W						
R908	RK73HH1J223D	MG RESISTOR	22K D 1/16W		L1	LB73Z0AF-001	CHIP FERRITE BEADS		
R909	RK73HH1J223D	MG RESISTOR	22K D 1/16W		L2	LB73Z0AF-001	CHIP FERRITE BEADS		
R911	RK73HH1J104D	MG RESISTOR	100K D 1/16W		L3	LB73Z0AF-001	CHIP FERRITE BEADS		
R912	RK73HB1J102J	MG RESISTOR	1.0K J 1/16W		L4	LB73H0AV-002	CHIP FERRITE BEADS		
R913	RK73HB1J000J	MG RESISTOR	0.0 J 1/16W		L5	LB73G0AK-001	CHIP FERRITE BEADS		
R914	RK73HB1J102J	MG RESISTOR	1.0K J 1/16W		L6	LB73G0AM-004	CHIP FERRITE BEADS		
R915	RK73HB1J000J	MG RESISTOR	0.0 J 1/16W		L7	LB73G0AK-001	CHIP FERRITE BEADS		
R916	RK73HB1J222J	MG RESISTOR	2.2K J 1/16W		L9	LB73G0AK-001	CHIP FERRITE BEADS		
R917	RK73HB1J000J	MG RESISTOR	0.0 J 1/16W		L10	LB73G0AK-001	CHIP FERRITE BEADS		
R918	RK73HB1J683J	MG RESISTOR	68K J 1/16W		L11	L41-4792-69	SMALL FIXED INDUCTOR	4.7UH	
R919	RK73HH1J473D	MG RESISTOR	47K D 1/16W		L12	LB73G0AM-004	CHIP FERRITE BEADS		
R920	RK73HB1J000J	MG RESISTOR	0.0 J 1/16W		L13	LR79Z0AA150M	CHIP INDUCTOR		
R921	RK73HB1J102J	MG RESISTOR	1.0K J 1/16W		L14	LB73G0AK-001	CHIP FERRITE BEADS		
R922	RK73HB1J681J	MG RESISTOR	680 J 1/16W		L15	LB73G0AK-001	CHIP FERRITE BEADS		
R923	RK73HB1J000J	MG RESISTOR	0.0 J 1/16W		L16	LB73H0AY-004	CHIP FERRITE BEADS		
R924	RK73HH1J473D	MG RESISTOR	47K D 1/16W		L80	LB73H0AV-003	CHIP FERRITE BEADS		
R925	RK73HH1J273D	MG RESISTOR	27K D 1/16W		L100	LB73H0AV-003	CHIP FERRITE BEADS		
R926	RK73HH1J103D	MG RESISTOR	10K D 1/16W		L101	LB73H0AV-003	CHIP FERRITE BEADS		
R927	RK73HB1J474J	MG RESISTOR	470K J 1/16W		L102	LB73H0AV-003	CHIP FERRITE BEADS		
R928	RK73HH1J103D	MG RESISTOR	10K D 1/16W		L103	LB73H0AV-003	CHIP FERRITE BEADS		
R930	RK73HH1J103D	MG RESISTOR	10K D 1/16W		L112	LB73H0AY-004	CHIP FERRITE BEADS		
R932	RK73HH1J473D	MG RESISTOR	47K D 1/16W		L113	LK73G0AFR27J	M.CHIP INDUCTOR	270NH	
R933	RK73HB1J000J	MG RESISTOR	0.0 J 1/16W		L114	LK73G0AFR27J	M.CHIP INDUCTOR	270NH	
R935	RK73HB1J102J	MG RESISTOR	1.0K J 1/16W		L115	LK73G0AFR27J	M.CHIP INDUCTOR	270NH	
R936	RK73GB2A101J	MG RESISTOR	100 J 1/10W		L116	LK73G0AFR27J	M.CHIP INDUCTOR	270NH	
R937	RK73HB1J000J	MG RESISTOR	0.0 J 1/16W		L117	LR79Z0CM28NG	CHIP INDUCTOR		
R938	RK73HH1J332D	MG RESISTOR	3.3K D 1/16W		L118	LK73G0AFR27J	M.CHIP INDUCTOR	270NH	
R939	RK73HB1J392J	MG RESISTOR	3.9K J 1/16W		L119	LK73G0AFR27J	M.CHIP INDUCTOR	270NH	
R940	RK73HB1J392J	MG RESISTOR	3.9K J 1/16W		L120	LB73H0AV-003	CHIP FERRITE BEADS		
R941	RK73GB2A101J	MG RESISTOR	100 J 1/10W		L121	LB73H0AV-003	CHIP FERRITE BEADS		
R943	RK73GB2A000J	MG RESISTOR	0.0 J 1/10W		L122	LB73H0AY-004	CHIP FERRITE BEADS		
R944	RK73HH1J473D	MG RESISTOR	47K D 1/16W		L123	LK73G0AFR27J	M.CHIP INDUCTOR	270NH	
R945	RK73HH1J472D	MG RESISTOR	4.7K D 1/16W		L124	LK73G0AFR27J	M.CHIP INDUCTOR	270NH	
R947	RK73HB1J101J	MG RESISTOR	100 J 1/16W		L125	LK73G0AFR27J	M.CHIP INDUCTOR	270NH	
R948	RK73HB1J000J	MG RESISTOR	0.0 J 1/16W		L126	LK73G0AFR27J	M.CHIP INDUCTOR	270NH	
R949	RK73HH1J472D	MG RESISTOR	4.7K D 1/16W		L127	LR79Z0CM28NG	CHIP INDUCTOR		
R950	RK73GB2A000J	MG RESISTOR	0.0 J 1/10W		L128	LK73G0AFR27J	M.CHIP INDUCTOR	270NH	
R951	RK73HB1J100J	MG RESISTOR	10 J 1/16W		L129	LK73G0AFR27J	M.CHIP INDUCTOR	270NH	
R953	RK73HH1J472D	MG RESISTOR	4.7K D 1/16W		L130	LK73H0AM12NJ	M.CHIP INDUCTOR	12NH	
R954	RK73HH1J472D	MG RESISTOR	4.7K D 1/16W		L131	LK73H0AM12NJ	M.CHIP INDUCTOR	12NH	
R955	RK73HB1J100J	MG RESISTOR	10 J 1/16W		L132	LK73H0AM12NJ	M.CHIP INDUCTOR	12NH	
R956	RK73HB1J000J	MG RESISTOR	0.0 J 1/16W		L133	LK73H0AM12NJ	M.CHIP INDUCTOR	12NH	
R957	RK73HB1J101J	MG RESISTOR	100 J 1/16W		L134	L41-6865-53	MULTILAYER CHIP INDUCTOR		
R958	RK73GB2A102J	MG RESISTOR	1.0K J 1/10W		L135	L41-8265-53	MULTILAYER CHIP INDUCTOR		
R960	RK73HH1J103D	MG RESISTOR	10K D 1/16W		L136	L41-1275-53	MULTILAYER CHIP INDUCTOR		
R961	RK73GB2A102J	MG RESISTOR	1.0K J 1/10W		L137	L41-1275-53	MULTILAYER CHIP INDUCTOR		
R962	RK73HH1J473D	MG RESISTOR	47K D 1/16W		L138	LB73H0AV-003	CHIP FERRITE BEADS		
R963	RK73HB1J101J	MG RESISTOR	100 J 1/16W		L139	LK73H0AM12NJ	M.CHIP INDUCTOR	12NH	
R964	RK73HB1J101J	MG RESISTOR	100 J 1/16W		L140	LB73H0AY-004	CHIP FERRITE BEADS		
R965	RK73HB1J471J	MG RESISTOR	470 J 1/16W		L141	LB73H0AY-004	CHIP FERRITE BEADS		

△ Symbol No.	Part No.	Part Name	Description	Local	△ Symbol No.	Part No.	Part Name	Description	Local
L142	LK73G0AFR27J	M.CHIP INDUCTOR	270NH		L701	LB73H0AV-003	CHIP FERRITE BEADS		
L300	L40-3363-71	SMALL FIXED INDUCTOR	3.3NH		L702	LB73G0AK-001	CHIP FERRITE BEADS		
L301	LK73H0AM33NJ	M.CHIP INDUCTOR	33NH		L711	LR77Z0AE4R7J	CHIP INDUCTOR		
L302	L40-3363-71	SMALL FIXED INDUCTOR	3.3NH		L713	LB73H0AV-002	CHIP FERRITE BEADS		
L303	LK73H0AM4N7S	M.CHIP INDUCTOR	4.7NH		L714	LB73G0AM-004	CHIP FERRITE BEADS		
L304	LK73H0AM27NJ	M.CHIP INDUCTOR	27NH		L715	L92-1101-05	CHIP FERRITE		
L305	LK73H0AM68NJ	M.CHIP INDUCTOR	38NH		L716	L92-1101-05	CHIP FERRITE		
L306	L40-5663-92	SMALL FIXED INDUCTOR	5.6NH		L717	L92-1101-05	CHIP FERRITE		
L307	L41-2763-14	SMALL FIXED INDUCTOR	2.7NH		L718	L92-1101-05	CHIP FERRITE		
L308	LB73F0AV-002	CHIP FERRITE BEADS			L719	LB73H0AV-002	CHIP FERRITE BEADS		
L309	L40-5663-92	SMALL FIXED INDUCTOR	5.6NH		L720	LB73G0AK-001	CHIP FERRITE BEADS		
L310	L40-5663-92	SMALL FIXED INDUCTOR	5.6NH		L721	LB73G0AK-001	CHIP FERRITE BEADS		
L311	L40-3963-92	SMALL FIXED INDUCTOR	3.9NH		L722	LB73G0AK-001	CHIP FERRITE BEADS		
L312	L41-5668-14	SMALL FIXED INDUCTOR	5.6NH		L723	LB73H0AV-002	CHIP FERRITE BEADS		
L313	LB73F0AV-002	CHIP FERRITE BEADS			L724	LB73G0AK-001	CHIP FERRITE BEADS		
L314	L41-5668-14	SMALL FIXED INDUCTOR	5.6NH		L725	LB73H0AV-002	CHIP FERRITE BEADS		
L315	L41-2763-14	SMALL FIXED INDUCTOR	2.7NH		L726	L79-1984-05	FILTER		
L316	LB73G0BA-004	CHIP FERRITE BEADS			L728	L79-1984-05	FILTER		
L317	L34-4994-05	SMALL FIXED INDUCTOR	47.0NH		L729	L79-1984-05	FILTER		
L318	LB73G0BA-004	CHIP FERRITE BEADS			L730	L79-1984-05	FILTER		
L319	L34-4560-05	SMALL FIXED INDUCTOR	47.0NH		L731	L79-1984-05	FILTER		
L320	LB73H0AV-003	CHIP FERRITE BEADS			L732	L92-1101-05	CHIP FERRITE		
L323	LR77Z0AA22NJ	CHIP INDUCTOR	22NH		L901	LB73H0AV-003	CHIP FERRITE BEADS		
L324	LR77Z0AA27NJ	CHIP INDUCTOR	27NH		L902	LB73H0AV-003	CHIP FERRITE BEADS		
L325	L34-4613-05	SMALL FIXED INDUCTOR	67NH		L906	LB73G0BA-004	CHIP FERRITE BEADS		
L326	L41-3378-55	SMALL FIXED INDUCTOR	33NH		L907	LB73G0BA-004	CHIP FERRITE BEADS		
L327	L34-4650-05	SMALL FIXED INDUCTOR	5.3NH						
L328	LR79Z0DA8N0G	CHIP INDUCTOR	8NH		A1	W02-3785-05	DC-DC CONVERTER		
L329	LR79Z0DA8N0G	CHIP INDUCTOR	8NH		CN2	E23-1260-14	TERMINAL		
L330	LR79Z0DA8N0G	CHIP INDUCTOR	8NH		CN3	E23-1260-14	TERMINAL		
L331	L41-1561-55	SMALL FIXED INDUCTOR	1.5NH		CN4	E41-1682-05	PIN ASSY		
L333	LB73H0AV-003	CHIP FERRITE BEADS			CN12	J19-5386-05	HOLDER		
L500	L39-1498-05	TOROIDAL COIL			CN731	E40-6720-05	SOCKET FOR PIN ASSY		
L501	LB73G0BD-005	CHIP FERRITE BEADS			CN735	E40-6862-05	FLAT CABLE CONNECTOR		
L502	L41-8285-14	SMALL FIXED INDUCTOR	820NH		CN749	EC720AA-0550A	FLAT CABLE CONNECTOR SMD		
L503	L41-8285-14	SMALL FIXED INDUCTOR	820NH		CN900	E41-2723-05	PIN ASSY		
L504	LK73H0AM15NJ	M.CHIP INDUCTOR	15NH		CN906	E40-6560-05	FLAT CABLE CONNECTOR		
L505	LK73G0AF8N2J	M.CHIP INDUCTOR	8.2NH		CN907	E40-6560-05	FLAT CABLE CONNECTOR		
L506	LK73H0AM10NJ	M.CHIP INDUCTOR	10NH		CN910	E40-6582-05	PIN ASSY		
L507	LK73H0AM10NJ	M.CHIP INDUCTOR	10NH		CP100	RK74HB1J100J	NET RESISTOR	10 J 1/16W	
L508	LK73H0AM12NJ	M.CHIP INDUCTOR	12NH		CP600	RK74HB1J100J	NET RESISTOR	10 J 1/16W	
L510	L79-1927-05	FILTER			CP701	RK74HB1J103J	NET RESISTOR	10K J 1/16W	
L511	L79-1928-05	FILTER			CP702	RK74HB1J102J	NET RESISTOR	1.0K J 1/16W	
L513	L40-3363-71	SMALL FIXED INDUCTOR	3.3NH		CP703	RK74HB1J100J	NET RESISTOR	10 J 1/16W	
L514	LK73H0AM8N2J	M.CHIP INDUCTOR	8.2NH		CP704	RK74HB1J100J	NET RESISTOR	10 J 1/16W	
L515	L41-1578-08	SMALL FIXED INDUCTOR	15NH		CP705	RK74HB1J100J	NET RESISTOR	10 J 1/16W	
L516	L41-1878-08	SMALL FIXED INDUCTOR	18NH		CP706	RK74HB1J101J	NET RESISTOR	100 J 1/16W	
L517	LK73H0AM5N6S	M.CHIP INDUCTOR	5.6NH		CP707	RK74HB1J101J	NET RESISTOR	100 J 1/16W	
L518	LK73H0AM6N8J	M.CHIP INDUCTOR	6.8NH		CP708	RK74HB1J101J	NET RESISTOR	100 J 1/16W	
L519	LB73G0BA-004	CHIP FERRITE BEADS			CP709	RK74HB1J101J	NET RESISTOR	100 J 1/16W	
L520	LB73G0BA-004	CHIP FERRITE BEADS			CP710	RK74HB1J101J	NET RESISTOR	100 J 1/16W	
L521	L79-1927-05	FILTER			CP711	RK74HB1J101J	NET RESISTOR	100 J 1/16W	
L522	L79-1928-05	FILTER			CP716	RK74HB1J101J	NET RESISTOR	100 J 1/16W	
L600	LK73G0AQ100K	M.CHIP INDUCTOR	10UH		CP717	RK74HB1J470J	NET RESISTOR	47 J 1/16W	
L601	LB73H0AV-003	CHIP FERRITE BEADS			CP718	RK74HB1J470J	NET RESISTOR	47 J 1/16W	
L602	LB73H0AV-003	CHIP FERRITE BEADS			CP719	RK74HB1J470J	NET RESISTOR	47 J 1/16W	
L603	L41-2788-55	SMALL FIXED INDUCTOR	270NH		CP720	RK74HB1J470J	NET RESISTOR	47 J 1/16W	
L604	LB73H0AV-003	CHIP FERRITE BEADS			CP721	RK74HB1J470J	NET RESISTOR	47 J 1/16W	
L605	L41-2785-53	SMALL FIXED INDUCTOR	270NH		CP900	RK74HB1J100J	NET RESISTOR	10 J 1/16W	
L606	L41-4798-14	SMALL FIXED INDUCTOR	4.7UF		CP901	RK74HA1J100J	NET RESISTOR	10 J 1/16W	
L607	L41-1885-53	SMALL FIXED INDUCTOR	0.18UH		E2	F10-3226-05	SHIELDING CASE		
L608	LB73H0AV-003	CHIP FERRITE BEADS			E100	F10-3244-15	SHIELDING CASE		
L609	LB73H0AV-003	CHIP FERRITE BEADS			E600	F10-3224-15	SHIELDING CASE		
L610	L41-1885-53	SMALL FIXED INDUCTOR	0.18UH		F1	F53-0286-05	FUSE	2.5A	
L611	LK73G0AQ100K	M.CHIP INDUCTOR	10UH		F2	FZA10BS-5R0	FUSE	5.0A	
L612	LK73G0AQ100K	M.CHIP INDUCTOR	10UH		F3	FZA10BS-5R0	FUSE	5.0A	
L613	LB73H0AV-003	CHIP FERRITE BEADS			F300	FZA10BQ-3R15	FUSE	3.15A	
L614	LB73H0AV-003	CHIP FERRITE BEADS			F900	F53-0286-05	FUSE	2.5A	
L615	LK73G0AQR33K	M.CHIP INDUCTOR	330NH		J700	E68-0426-05	JACK(OTHERS)		
L616	LB73H0AV-002	CHIP FERRITE BEADS			J900	E1B-0001-00	3.5D PHONE JACK		
L617	LK73G0AQR82K	M.CHIP INDUCTOR	820NH		J901	E58-0521-05	SUB SOCKET(D)		
L618	LK73G0AQR2R2K	M.CHIP INDUCTOR	2.2UH		TH301	ERTJ0V104H	NEGATIVE TEMP THERMISTOR		
L619	L40-6881-86	SMALL FIXED INDUCTOR	0.68UH		TH302	ERTJ0V104H	NEGATIVE TEMP THERMISTOR		
L620	LB73H0AV-002	CHIP FERRITE BEADS			TH305	ERTJ0V104H	NEGATIVE TEMP THERMISTOR		
L621	L41-1098-14	SMALL FIXED INDUCTOR	10UH		TH306	ERTJ0V104H	NEGATIVE TEMP THERMISTOR		
L625	LK73G0ASR39J	SMALL FIXED INDUCTOR	390NH		TH700	ERTJ0V104H	NEGATIVE TEMP THERMISTOR		
L626	LK73G0AQ100K	M.CHIP INDUCTOR	10UH		X700	L77-3123-05	TCXO	19.2M	
L700	LB73G0AK-001	CHIP FERRITE BEADS			X701	L77-1802-05	CRYSTAL RESONATOR	32768HZ	

Symbol No.	Part No.	Part Name	Description	Local
XF600	L7B-0001-00	MCF		

MODULE (BT/GPS) UNIT

XC2-0031-80

***Note : This part cannot be replaced. Therefore, this part is not supplied as a service part.**

Block No. [0][2]

Symbol No.	Part No.	Part Name	Description	Local
IC1	74AVC4TD245GU	IC		
IC2	BU18TD2WNVX	IC		
IC3	-----	IC	*Note	
IC4	NJM2878F4-33	IC		
IC5	-----	IC	*Note	
IC6	74AVC4TD245GU	IC		
IC7	74AVC4TD245GU	IC		
Q1	EM6M2	FET		
D17	RN262CS	DIODE		
D18	RN262CS	DIODE		
C1	CK73HB1A474K	C CAPACITOR	0.47UF K	
C2	CK73HB1A474K	C CAPACITOR	0.47UF K	
C3	CK73HB1E104K	C CAPACITOR	0.10UF K	
C4	CK73HB1E104K	C CAPACITOR	0.10UF K	
C5	CK73HB1A105K	C CAPACITOR	1.0UF K	
C6	CK73HB1A474K	C CAPACITOR	0.47UF K	
C7	CK73HB1A474K	C CAPACITOR	0.47UF K	
C8	CC73HCH1H220J	C CAPACITOR	22PF J	
C9	CC73HCH1H100B	C CAPACITOR	10PF B	
C10	CK73HB1A105K	C CAPACITOR	1.0UF K	
C11	CK73HB1E104K	C CAPACITOR	0.10UF K	
C12	CK73HB1E104K	C CAPACITOR	0.10UF K	
C13	CK73HB1E104K	C CAPACITOR	0.10UF K	
C14	CK73HB1E104K	C CAPACITOR	0.10UF K	
C15	CK73HB1A105K	C CAPACITOR	1.0UF K	
C16	CK73HB1E104K	C CAPACITOR	0.10UF K	
C17	CK73HB1E104K	C CAPACITOR	0.10UF K	
C18	CC73HCH1H180J	C CAPACITOR	18PF J	
C19	CC73HCH1H180J	C CAPACITOR	18PF J	
C20	CK73HB1A105K	C CAPACITOR	1.0UF K	
C21	CK73HB1A105K	C CAPACITOR	1.0UF K	
C22	CK73HB1E104K	C CAPACITOR	0.10UF K	
C23	CK73HBB1H102K	C CAPACITOR	1000PF K	
C24	CK73HB1E104K	C CAPACITOR	0.10UF K	
C25	CK73HBB1H102K	C CAPACITOR	1000PF K	
C26	CK73HBB1H102K	C CAPACITOR	1000PF K	
C27	CK73HBB1H102K	C CAPACITOR	1000PF K	
C28	CK73HB1E104K	C CAPACITOR	0.10UF K	
C29	CK73HB1E104K	C CAPACITOR	0.10UF K	
C30	CK73HB1E104K	C CAPACITOR	0.10UF K	
C31	CK73HB1A105K	C CAPACITOR	1.0UF K	
C32	CK73HB1E104K	C CAPACITOR	0.10UF K	
C33	CK73HB1E104K	C CAPACITOR	0.10UF K	
C34	CK73HB1E104K	C CAPACITOR	0.10UF K	
C35	CK73HB1E104K	C CAPACITOR	0.10UF K	
C36	CC73HCH1H220J	C CAPACITOR	22PF J	
C37	CC73HCH1H220J	C CAPACITOR	22PF J	
C38	CC73HCH1H2R5B	C CAPACITOR	2.5PF B	
C39	CK73HB1E104K	C CAPACITOR	0.10UF K	
C40	CC73HCH1H180J	C CAPACITOR	18PF J	
C44	CK73HB1E104K	C CAPACITOR	0.10UF K	
C45	CK73HB1E104K	C CAPACITOR	0.10UF K	
C46	CK73HB1E104K	C CAPACITOR	0.10UF K	
C47	CK73HB1E104K	C CAPACITOR	0.10UF K	
C48	CK73HB1E104K	C CAPACITOR	0.10UF K	
C49	CK73HB1E104K	C CAPACITOR	0.10UF K	
C50	CC73HCH1H470J	C CAPACITOR	47PF J	
C68	CC73HCH1H010B	C CAPACITOR	1.0PF B	

Symbol No.	Part No.	Part Name	Description	Local
R1	RK73HB1J101J	MG RESISTOR	100 J 1/16W	
R2	RK73HB1J103J	MG RESISTOR	10K J 1/16W	
R3	RK73HB1J103J	MG RESISTOR	10K J 1/16W	
R4	RK73HB1J101J	MG RESISTOR	100 J 1/16W	
R7	RK73HB1J101J	MG RESISTOR	100 J 1/16W	
R8	RK73HB1J102J	MG RESISTOR	1.0K J 1/16W	
R9	RK73HB1J104J	MG RESISTOR	100K J 1/16W	
R10	RK73HB1J104J	MG RESISTOR	100K J 1/16W	
R11	RK73HB1J102J	MG RESISTOR	1.0K J 1/16W	
R12	RK73HB1J473J	MG RESISTOR	47K J 1/16W	
R13	RK73HB1J473J	MG RESISTOR	47K J 1/16W	
R14	RK73HB1J102J	MG RESISTOR	1.0K J 1/16W	
R15	RK73HB1J102J	MG RESISTOR	1.0K J 1/16W	
R16	RK73EB2E100J	MG RESISTOR	10 J 1/4W	
R18	RK73HB1J000J	MG RESISTOR	0.0 J 1/16W	
R19	RK73HB1J102J	MG RESISTOR	1.0K J 1/16W	
R21	RK73HB1J000J	MG RESISTOR	0.0 J 1/16W	
R22	RK73HB1J103J	MG RESISTOR	10K J 1/16W	
R23	RK73HB1J000J	MG RESISTOR	0.0 J 1/16W	
R24	RK73HB1J000J	MG RESISTOR	0.0 J 1/16W	
R25	RK73HB1J103J	MG RESISTOR	10K J 1/16W	
R26	RK73HB1J000J	MG RESISTOR	0.0 J 1/16W	
R27	RK73HB1J000J	MG RESISTOR	0.0 J 1/16W	
R29	RK73HB1J000J	MG RESISTOR	0.0 J 1/16W	

L1	LB73H0AV-002	CHIP FERRITE BEADS		
L2	LB73G0AK-001	CHIP FERRITE BEADS		
L3	LB73G0BJ-002	CHIP FERRITE BEADS		
L4	L92-0487-05	CHIP FERRITE		
L5	L92-0487-05	CHIP FERRITE		
L6	LK73H0AG27NJ	M.CHIP INDUCTOR	27NH	
L7	LK73H0AM10NJ	M.CHIP INDUCTOR	10NH	
L8	L92-0487-05	CHIP FERRITE		
L9	L79-1985-05	FILTER		
L11	L79-1987-05	FILTER		
L13	L92-0487-05	CHIP FERRITE		
L14	L92-0487-05	CHIP FERRITE		
L15	L40-2263-71	SMALL FIXED INDUCTOR	2.2NH	
CN1	E40-6879-05	FLAT CABLE CONNECTOR		
CN5	E0E-0012-00	RF COAXIAL CABLE RECEPTACLE		
CP1	RK74HB1J100J	NET RESISTOR	10 J 1/16W	
CP2	RK74HB1J100J	NET RESISTOR	10 J 1/16W	
E1	F10-3226-05	SHIELDING CASE		
X1	L77-3123-05	TCXO	19.2M	
X2	L77-3121-05	CRYSTAL RESONATOR	32.768K	

SUB (DISPLAY) UNIT

XC3-0020-20(NX-5900_K)

Block No. [0][3]

Symbol No.	Part No.	Part Name	Description	Local
IC1	MM3404A50URE	IC		
IC2	BU30TD2WNVX	IC		
IC3	TC7WT125FUF	IC		
IC4	BD11600NUX	IC		
IC6	BH1721FVC	IC		
IC8	BD1754HFN	IC		
IC9	TC7WH126FK	IC		
IC10	TC35894FG	IC		
IC12	TC7SZ08FE	IC		
Q2	SSM6N37FE	FET		
Q3	LTC014EEBFS8	DIGI TRANSISTOR		
Q4	LTC014EEBFS8	DIGI TRANSISTOR		
Q6	LTC014EEBFS8	DIGI TRANSISTOR		
D1	SPC10501A01	VARIATOR		
D2	SPC10501A01	VARIATOR		
D4	B30-2365-05	LED	WHITE	
D5	B30-2365-05	LED	WHITE	

△ Symbol No.	Part No.	Part Name	Description	Local	△ Symbol No.	Part No.	Part Name	Description	Local
D6	B30-2365-05	LED	WHITE		R12	RK73HB1J000J	MG RESISTOR	0.0 J 1/16W	
D7	B30-2365-05	LED	WHITE		R17	RK73HB1J000J	MG RESISTOR	0.0 J 1/16W	
D9	B30-2365-05	LED	WHITE		R18	RK73HB1J000J	MG RESISTOR	0.0 J 1/16W	
D10	B30-2365-05	LED	WHITE		R19	RK73HB1J000J	MG RESISTOR	0.0 J 1/16W	
D11	B30-2365-05	LED	WHITE		R20	RK73HB1J101J	MG RESISTOR	100 J 1/16W	
D12	B30-2365-05	LED	WHITE		R21	RK73HB1J331J	MG RESISTOR	330 J 1/16W	
D14	B30-2365-05	LED	WHITE		R22	RK73HB1J331J	MG RESISTOR	330 J 1/16W	
D15	B30-2365-05	LED	WHITE		R23	RK73HB1J331J	MG RESISTOR	330 J 1/16W	
D16	B30-2365-05	LED	WHITE		R24	RK73HB1J331J	MG RESISTOR	330 J 1/16W	
D20	DZ2J062(M)	ZENER DIODE			R25	RK73HB1J101J	MG RESISTOR	100 J 1/16W	
D21	B30-2364-05	LED	RGB		R26	RK73HB1J222J	MG RESISTOR	2.2K J 1/16W	
D22	RB521CM-30	DIODE			R27	RK73HB1J331J	MG RESISTOR	330 J 1/16W	
D23	SPC10501A01	VARISTOR			R28	RK73HB1J331J	MG RESISTOR	330 J 1/16W	
D24	SPC10501A01	VARISTOR			R29	RK73HB1J331J	MG RESISTOR	330 J 1/16W	
D25	MINISMDC020F	VARISTOR			R30	RK73HB1J331J	MG RESISTOR	330 J 1/16W	
D26	SPC10501A01	VARISTOR			R31	RK73HB1J101J	MG RESISTOR	100 J 1/16W	
D27	SPC10501A01	VARISTOR			R32	RK73HB1J331J	MG RESISTOR	330 J 1/16W	
D28	DZ2S068M	ZENER DIODE			R33	RK73HB1J331J	MG RESISTOR	330 J 1/16W	
D29	DZ2S068M	ZENER DIODE			R34	RK73HB1J331J	MG RESISTOR	330 J 1/16W	
D30	DZ2S068M	ZENER DIODE			R38	RK73HB1J101J	MG RESISTOR	100 J 1/16W	
D31	EMZ6.8N	ZENER DIODE			R39	RK73HB1J101J	MG RESISTOR	100 J 1/16W	
D32	DZ2S068M	ZENER DIODE			R40	RK73HB1J101J	MG RESISTOR	100 J 1/16W	
C2	CC73GCH1H101J	C CAPACITOR	100PF J		R41	RK73HB1J101J	MG RESISTOR	100 J 1/16W	
C5	CK73GXR1H104K	C CAPACITOR	0.1UF K		R42	RK73HB1J102J	MG RESISTOR	1.0K J 1/16W	
C8	C93-1810-05	C CAPACITOR	4.7UF K		R43	RK73HB1J102J	MG RESISTOR	1.0K J 1/16W	
C9	CC73GCH1H101J	C CAPACITOR	100PF J		R46	RK73HB1J681J	MG RESISTOR	680 J 1/16W	
C11	CK73GXR1H104K	C CAPACITOR	0.1UF K		R47	RK73HB1J103J	MG RESISTOR	10K J 1/16W	
C16	CC73GCH1H101J	C CAPACITOR	100PF J		R48	RK73GB2A151J	MG RESISTOR	150 J 1/10W	
C18	CK73GXR1H104K	C CAPACITOR	0.1UF K		R49	RK73HB1J222J	MG RESISTOR	2.2K J 1/16W	
C22	CC73GCH1H101J	C CAPACITOR	100PF J		R50	RK73HB1J222J	MG RESISTOR	2.2K J 1/16W	
C24	CK73GXR1H104K	C CAPACITOR	0.1UF K		R51	RK73HB1J222J	MG RESISTOR	2.2K J 1/16W	
C29	CC73GCH1H101J	C CAPACITOR	100PF J		R52	RK73HB1J102J	MG RESISTOR	1.0K J 1/16W	
C32	CC73GCH1H101J	C CAPACITOR	100PF J		R53	RK73HB1J103J	MG RESISTOR	10K J 1/16W	
C42	CC73GCH1H470J	C CAPACITOR	47PF J		R54	RK73HB1J473J	MG RESISTOR	47K J 1/16W	
C43	CC73GCH1H470J	C CAPACITOR	47PF J		R55	RK73HB1J473J	MG RESISTOR	47K J 1/16W	
C44	CC73HCH1H101J	C CAPACITOR	100PF J		R60	RK73HB1J000J	MG RESISTOR	0.0 J 1/16W	
C45	CK73GBB1H102K	C CAPACITOR	1000PF K		R61	RK73HB1J000J	MG RESISTOR	0.0 J 1/16W	
C46	CK73GBB1H102K	C CAPACITOR	1000PF K		R62	RK73HB1J000J	MG RESISTOR	0.0 J 1/16W	
C48	CK73GBB1H102K	C CAPACITOR	1000PF K		R63	RK73HB1J000J	MG RESISTOR	0.0 J 1/16W	
C50	CK73GBB1H102K	C CAPACITOR	1000PF K		R64	RK73HB1J000J	MG RESISTOR	0.0 J 1/16W	
C52	CC73HCH1H101J	C CAPACITOR	100PF J		R65	RK73HB1J000J	MG RESISTOR	0.0 J 1/16W	
C53	CC73HCH1H101J	C CAPACITOR	100PF J		R66	RK73HB1J101J	MG RESISTOR	100 J 1/16W	
C54	CK73GB1E105K	C CAPACITOR	1.0UF K		R69	RK73HH1J274D	MG RESISTOR	270K D 1/16W	
C55	CC73HCH1H101J	C CAPACITOR	100PF J		R71	RK73GB2A000J	MG RESISTOR	0.0 J 1/10W	
C56	CC73HCH1H101J	C CAPACITOR	100PF J		R77	RK73HB1J222J	MG RESISTOR	2.2K J 1/16W	
C57	CK73GB1E105K	C CAPACITOR	1.0UF K		R78	RK73HB1J222J	MG RESISTOR	2.2K J 1/16W	
C58	CK73GB1E105K	C CAPACITOR	1.0UF K		R79	RK73HB1J222J	MG RESISTOR	2.2K J 1/16W	
C59	CK73GB1E105K	C CAPACITOR	1.0UF K		R81	RK73HB1J103J	MG RESISTOR	10K J 1/16W	
C62	CK73HB1E104K	C CAPACITOR	0.10UF K		R82	RK73HB1J222J	MG RESISTOR	2.2K J 1/16W	
C63	CK73GB1E105K	C CAPACITOR	1.0UF K		R83	RK73HB1J000J	MG RESISTOR	0.0 J 1/16W	
C64	CK73HB1E104K	C CAPACITOR	0.10UF K		R86	RK73GB2A000J	MG RESISTOR	0.0 J 1/10W	
C65	CK73HBB1E103K	C CAPACITOR	0.10UF K		R87	RK73HB1J222J	MG RESISTOR	2.2K J 1/16W	
C66	CK73HB1E104K	C CAPACITOR	0.10UF K		R88	RK73HB1J102J	MG RESISTOR	1.0K J 1/16W	
C67	CK73HB1E104K	C CAPACITOR	0.10UF K		R98	RK73HB1J222J	MG RESISTOR	2.2K J 1/16W	
C68	CK73HB1E104K	C CAPACITOR	0.10UF K		R99	RK73HB1J222J	MG RESISTOR	2.2K J 1/16W	
C69	CK73HB1E104K	C CAPACITOR	0.10UF K		L1	LB73G0AM-004	CHIP FERRITE BEADS		
C70	CK73GBB1H102K	C CAPACITOR	1000PF K		L2	LB73G0AM-004	CHIP FERRITE BEADS		
C71	CK73GXR1H104K	C CAPACITOR	0.1UF K		L3	LB73H0AV-003	CHIP FERRITE BEADS		
C73	CK73HB1E104K	C CAPACITOR	0.10UF K		L4	LB73H0AV-003	CHIP FERRITE BEADS		
C74	CK73GB1E105K	C CAPACITOR	1.0UF K		L5	LB73G0AM-004	CHIP FERRITE BEADS		
C75	CK73HB1E104K	C CAPACITOR	0.10UF K		L11	LB73H0AV-003	CHIP FERRITE BEADS		
C76	CK73GBB1H102K	C CAPACITOR	1000PF K		L14	LB73H0AV-003	CHIP FERRITE BEADS		
C79	CK73GBB1H102K	C CAPACITOR	1000PF K		L15	LB73G0AM-004	CHIP FERRITE BEADS		
C83	CK73HB1E104K	C CAPACITOR	0.10UF K		L16	LB73H0AV-003	CHIP FERRITE BEADS		
C84	CK73HB1E104K	C CAPACITOR	0.10UF K		L17	LB73H0AV-003	CHIP FERRITE BEADS		
C87	CC73HCH1H101J	C CAPACITOR	100PF J		L18	LB73H0AV-003	CHIP FERRITE BEADS		
C90	CK73GBB1H102K	C CAPACITOR	1000PF K		CN2	E41-2673-05	PIN ASSY		
C101	CK73GBB1H102K	C CAPACITOR	1000PF K		CN4	E40-6965-05	FLAT CABLE CONNECTOR		
R3	RK73HB1J000J	MG RESISTOR	0.0 J 1/16W		CN5	E41-2671-05	PIN ASSY		
R4	RK73HB1J000J	MG RESISTOR	0.0 J 1/16W		CN6	E40-6913-05	FLAT CABLE CONNECTOR		
R5	RK73HB1J000J	MG RESISTOR	0.0 J 1/16W		J1	E58-0535-05	MODULAR JACK		
R6	RK73HB1J000J	MG RESISTOR	0.0 J 1/16W		S1	S70-0901-05	TACT SWITCH		
R7	RK73HB1J000J	MG RESISTOR	0.0 J 1/16W		S2	S70-0901-05	TACT SWITCH		
R9	RK73HB1J000J	MG RESISTOR	0.0 J 1/16W		S3	S70-0901-05	TACT SWITCH		
R10	RK73HB1J000J	MG RESISTOR	0.0 J 1/16W		S4	S70-0901-05	TACT SWITCH		
R11	RK73HB1J000J	MG RESISTOR	0.0 J 1/16W		S5	S70-0901-05	TACT SWITCH		

△ Symbol No.	Part No.	Part Name	Description	Local
S6	S70-0901-05	TACT SWITCH		
S7	S70-0901-05	TACT SWITCH		
S8	S70-0901-05	TACT SWITCH		
S9	S70-0901-05	TACT SWITCH		
S10	S70-0901-05	TACT SWITCH		
S11	S70-0901-05	TACT SWITCH		
S12	S70-0901-05	TACT SWITCH		

Packing materials and accessories parts list (NX-5900_K)

Block No.M2MM

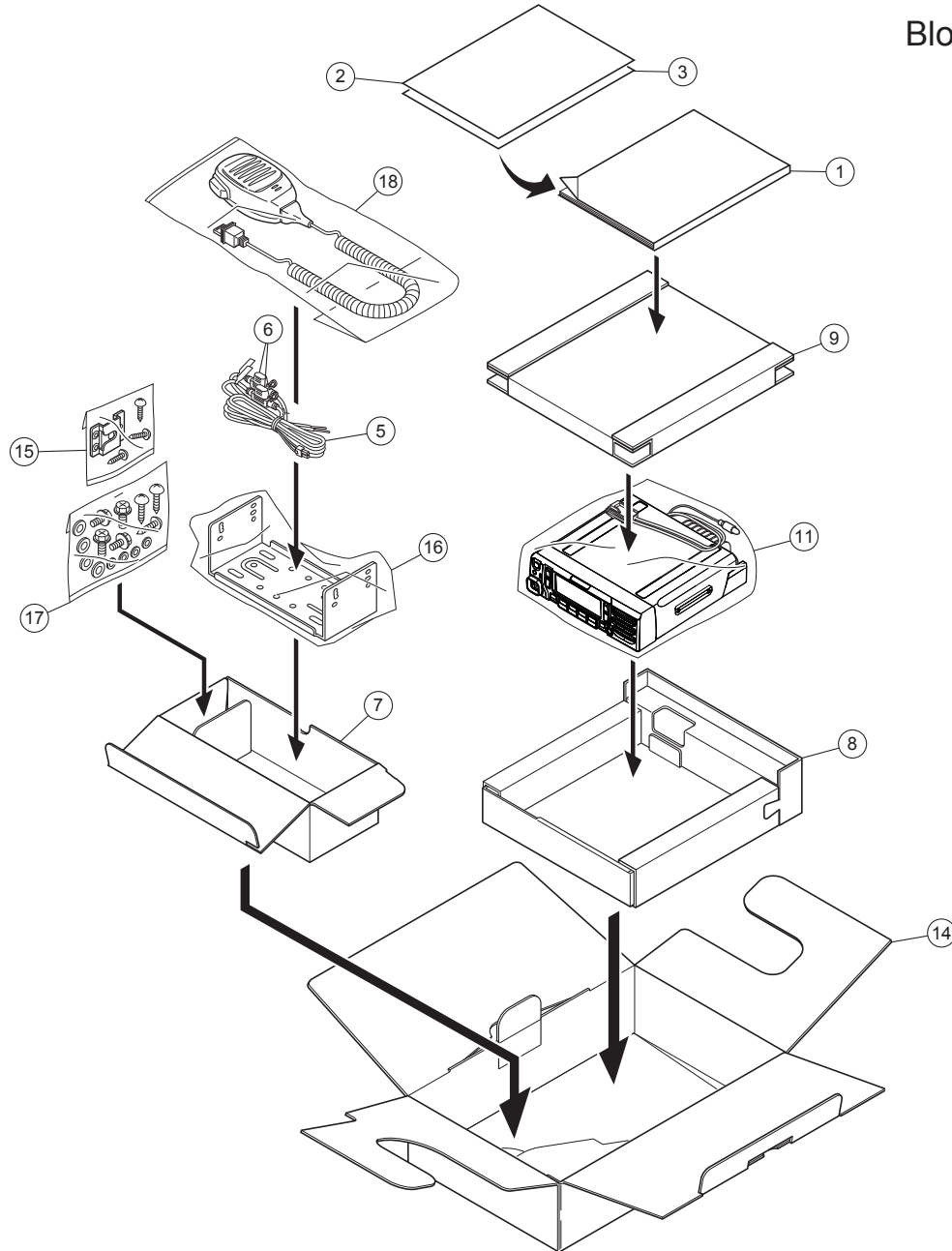

Packing and accessories

Block No. [M][2][M][M]
Local

△ Symbol No.	Part No.	Part Name	Description	Block No. [M][2][M][M] Local
1	B5A-0868-00	INSTRUCTION MANUAL		
2	-----	PAMPHLET		
3	-----	PAMPHLET		
5	E30-7523-65	DC CORD ASSY		
6	F52-0024-05	FUSE(BLADE TYPE)	15A(x2)	
7	H0C-0007-00	INNER CARTON CASE		
8	H1C-0077-00	PACKING FIXTURE(LOWER)		
9	H1C-0078-00	PACKING FIXTURE(UPPER)		
11	-----	PROTECTION BAG		
14	H5A-0618-00	ITEM CARTON		
15	J19-1584-15	HOLDER(MIC)		
16	-----	BRACKET		
17	N99-2039-05	SCREW SET		
18	T91-0639-65	MICROPHONE		

Packing materials and accessories parts list (NX-5900B_F,NX-5900B_K)

Block No.M3MM

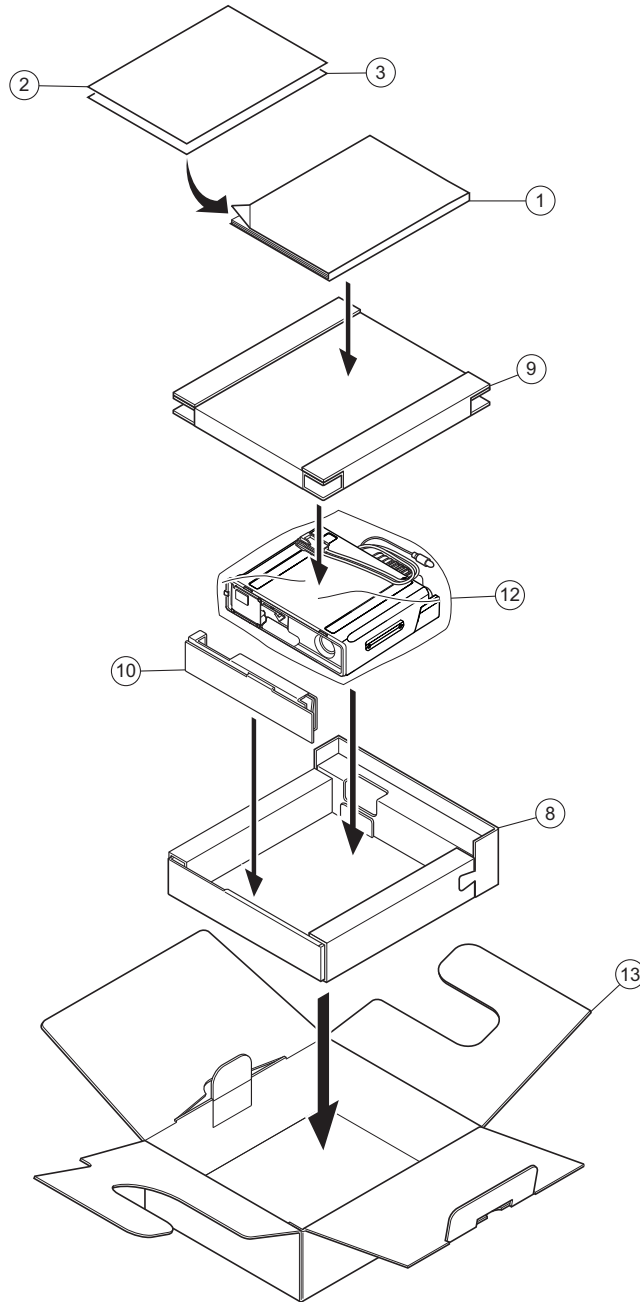

Packing and accessories

Block No. [M][3][M][M]
Local

Symbol No.	Part No.	Part Name	Description
1	B5A-0868-00	INSTRUCTION MANUAL	
2	-----	PAMPHLET	
3	-----	PAMPHLET	
8	H1C-0077-00	PACKING FIXTURE(LOWER)	
9	H1C-0078-00	PACKING FIXTURE(UPPER)	
10	H1C-0027-00	PACKING FIXTURE(SPACER)	
12	-----	ANTI-STATIC BAG	
13	H5A-0617-00	ITEM CARTON	

MEMO



KENWOOD

JVC KENWOOD Corporation
Communications Systems Business Unit

(No.RA032<Rev.001>)

Printed in Japan
VSE