

**RESIDENTIAL
PACKAGED GAS-ELECTRIC
COMBINATION UNITS**

**Service
Manual**

PGMD	NPGAA	NG4P0
PGME	NPGAB	NG6P0
	NPGAD	

This manual supports packaged gas-electric combination units manufactured after 1991

Manufactured by:

Inter-City Products
Corporation
Lavergne, TN USA 37086

**Part Number
462 081001 00**

TABLE OF CONTENTS

INTRODUCTION	1
UNIT IDENTIFICATION	2
FURNACE SECTION THEORY OF OPERATION	4
ELECTRICAL SUPPLY	4
GAS SUPPLY	5
BURNERS	7
CHECKING TEMPERATURE RISE	7
HIGH ALTITUDE OPERATION	8
ROOM THERMOSTATS	8
CONTROL WIRING	9
LIMIT SWITCHES	10
PRESSURE SWITCHES	11
EXHAUST BLOWER	12
CAPACITORS	12
HEATCRAFT & WATSCO (Cam-Stat) ELECTRONIC HEATING FAN TIMERS	13
HEATCRAFT & WATSCO (Cam-Stat) ELECTRONIC COOLING FAN TIMERS	14
HONEYWELL ST9120 Series FAN TIMER/FURNACE CONTROL ST9120 TESTING SEQUENCE	15
GAS VALVE/IGNITION CONTROL (HONEYWELL SV9500)	18
SV9500 SYSTEM OPERATION	19
HONEYWELL S8600M (SPARK -to- PILOT) IGNITION SYSTEM . BLOWER ASSEMBLY	20
BURNER/HEAT EXCHANGER INSPECTION & CLEANING	21
HEAT EXCHANGER REMOVAL/REPLACEMENT	24
ACCESSORY ECONOMIZERS	25
COMPRESSORS	26
COMPRESSOR CONTROL CIRCUIT	28
COMPRESSOR CHECKS	30
CONDENSER FAN CONTROL CIRCUIT	31
REFRIGERANT CHARGING	33
TECHNICAL SERVICE DATA INDEX	34
WIRING DIAGRAM INDEX	37
TROUBLESHOOTING CHARTS	78
	139

INTRODUCTION

This service manual is designed to be used in conjunction with the installation manual and/or technical support manual provided with each Packaged Gas/Electric Combination Unit.

This Packaged Gas/Electric Combination Unit represents the very latest in high efficiency gas furnace and electric cooling equipment technology. Consequently, certain controls within the unit consist of highly sophisticated electronic components which are **not user serviceable**. Therefore, it is essential that only competent, qualified, service personnel attempt to install, service, or maintain this product.

This Service manual was written to assist the professional HVAC service technician to quickly and accurately diagnose and repair any malfunctions of this product.

This service manual covers a variety of different models, including both Natural Gas models and LP Gas

(Propane) models. The overall operation of all of these models is essentially the same, with the exception of the differences of certain controls and/or components which may be unique to particular model and/or family.

This manual, therefore, will deal with all subjects in a general nature (I.E. all text will pertain to all models) unless that subject is unique to a particular model or family, in which case it will be so indicated.

Throughout the manual references may be made to "EARLIER MODELS" as well as "MORE RECENT MODELS". GENERALLY, the distinction between these two groups is based on a difference in fan controls and/or ignition systems used. These may not be the only differences, however, and the differences may vary from model to model within a particular family or series.

It will be necessary then for you to accurately identify the unit you are servicing, so you may be certain of a proper diagnosis and repair. (See Unit Identification Pg. 2)

WARNING

The information contained in this manual is intended for use by a qualified service technician who is familiar with the safety procedures required in installation and repair and who is equipped with the proper tools and test instruments.

Installation or repairs made by unqualified persons can result in hazards subjecting the unqualified person making such repairs to the risk of injury or electrical shock which can be serious, or even fatal not only to them, but also to persons being served by the equipment.

If you install or perform service on equipment, you must assume responsibility for any bodily injury or property damage which may result to you or others. We will not be responsible for any injury or property damage arising from improper installation, service, and/or service procedures.

UNIT IDENTIFICATION

The unit's rating plate contains important information for the service technician. It also lists the complete Model, Manufacturing, and Serial numbers. These complete numbers are required to obtain correct replacement parts as well as accurate service information.

Before attempting any adjustments, or replacing any components, be certain to check the unit's rating plate (located on the side panel) to obtain these complete numbers. The illustrations below will help you know more about the unit you are servicing.

Model Numbers Beginning with "PGA"

MODEL NUMBER	P	G	A	A	18	B	1	K
PRODUCT FAMILY P = Single Package								ELECTRICAL CHARACTERISTICS K = 208 / 230-1-60
FUEL (Heating) G = Gas								BLOWER OPTIONS 1 = Standard Direct Drive
DESIGN SERIES								GAS HEAT INPUT B = 40,000 F = 135,000 C = 60,000 G = 150,000 D = 90,000
RESIDENTIAL UNIT INDICATOR A = Standard Efficiency B = High Efficiency D = Ultra-High Efficiency								COOLING CAPACITY (NOMINAL BTUH) 18 = 1-1/2 Ton 42 = 3-1/2 Ton 24 = 2 Ton 47 = 4 Ton 30 = 2-1/2 Ton 60 = 5 Ton 36 = 3 Ton

Model Numbers Beginning with "G4P" or "G6P"

MODEL NUMBER	G	4	P	024	A	3	A												
PRODUCT TYPE G = Gas/Electric							HEATING CAPACITY (INPUT) A = 40,000 D = 115,000 B = 60,000 E = 135,000 C = 90,000 F = 150,000												
SERIES 4 = High Efficiency 6 = Super High Efficiency							ELECTRICAL CHARACTERISTICS												
UNIT IDENTIFIER P = Package/Residential							<table border="1"> <thead> <tr> <th>CODE</th> <th>PHASE</th> <th>CYCLE</th> <th>VOLTS</th> </tr> </thead> <tbody> <tr> <td>3</td> <td>1</td> <td>60</td> <td>208/230</td> </tr> <tr> <td>4</td> <td>3</td> <td>60</td> <td>208/230</td> </tr> </tbody> </table>	CODE	PHASE	CYCLE	VOLTS	3	1	60	208/230	4	3	60	208/230
CODE	PHASE	CYCLE	VOLTS																
3	1	60	208/230																
4	3	60	208/230																
PACKAGE & COMMERCIAL COOLING CAPACITY 024 = 2 Ton 042 = 3-1/2 Ton 030 = 2-1/2 Ton 048 = 4 Ton 036 = 3 Ton 060 = 5 Ton							SALES CODE												

Model Numbers Beginning With "PGM"

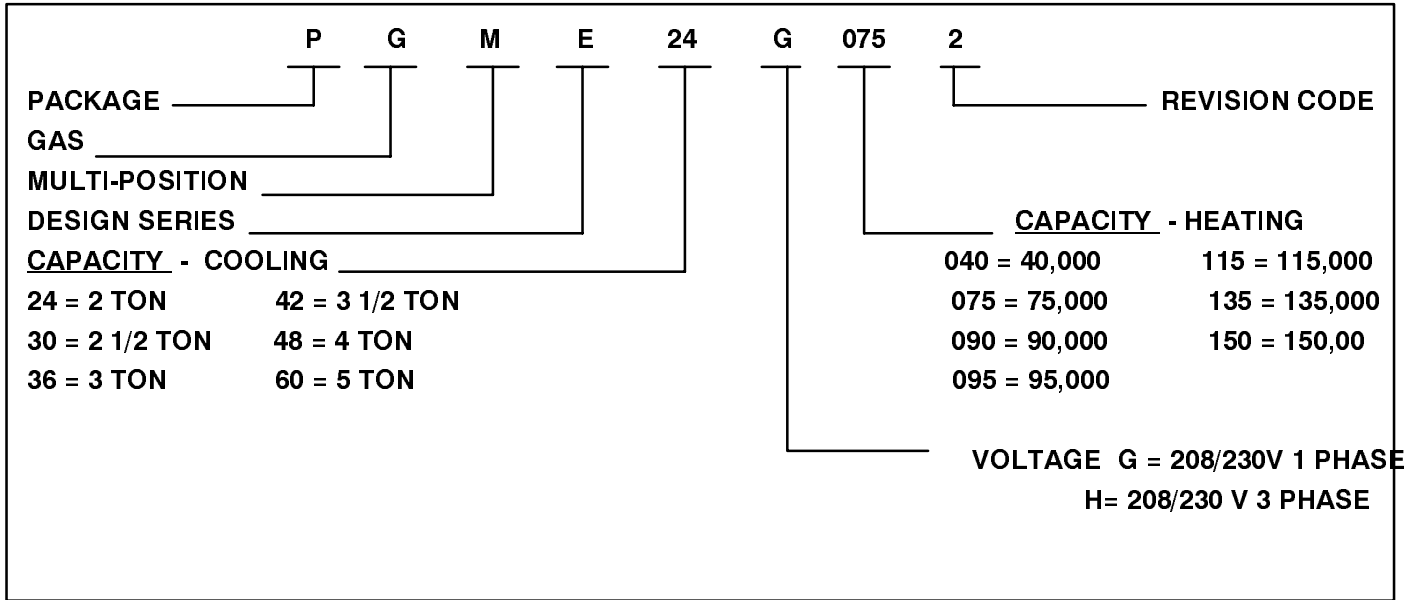
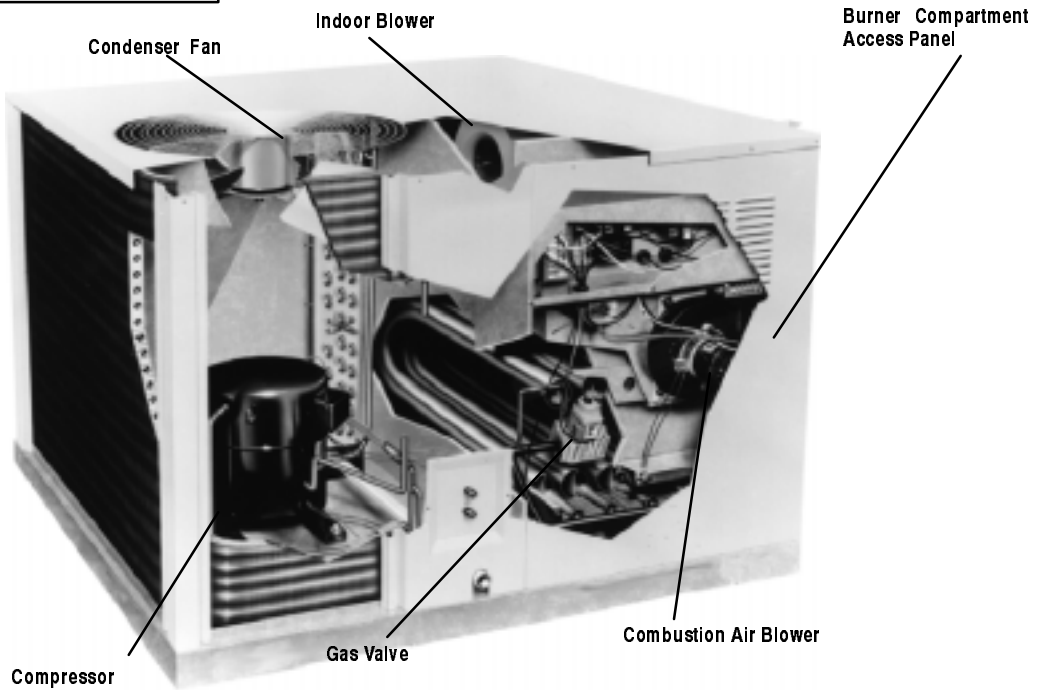

Figure 1 Component Locations



This illustration is for demonstration only. The exact size or position of some parts may not be the same on all units.

FURNACE SECTION THEORY OF OPERATION

The high efficiency and low profile of this Packaged Gas/Electric Unit have been obtained using design techniques not typical of traditional furnace designs. A brief description of these new design techniques and the purpose they serve follows.

1. The relatively low height of the unit coupled with the relatively high efficiency of most models requires maintaining the **surface area** of the heat exchanger, and yet minimizing the overall size.

The design required to achieve these results is the "Tubular" design, wherein the flue gasses must follow a horizontal "U" shaped passage through the heat exchanger, rather than simply rise to the top of the heat exchanger via convection.

This horizontal "U" path is resistive to normal convective flow, and requires that a partial vacuum be created at the outlet of the heat exchanger to maintain the flow of flue products through the heat exchanger.

2. The Tubular heat exchanger design does not lend itself well to the ribbon type, or slotted port type burner found in more traditional design furnaces for the following reasons:

- A. The secondary combustion air flows at right angles to the burner flame, making it likely to "pull" the flame off a ribbon or slotted port type burner.

- B. The flame "height" of a ribbon or slotted port type burner would make it difficult (if not impossible) to prevent impingement of the flame on the heat exchanger surfaces while maintaining the low profile heat exchanger.

For these reasons, an "INSHOT" type burner is used in this series. The inshot burner (also called a "jet" burner) fires a flame straight out its end. This burner is specifically designed to fire into a tube style heat exchanger, making it an ideal application.

3. To overcome the resistance to convective flow of the horizontal "U" tubular heat exchanger requires the use of an Induced Draft Combustion Blower Assembly.
4. The Combustion Blower Assembly is mounted on the outlet side of the heat exchanger. This blower creates a partial vacuum (negative pressure) within the heat exchanger drawing the flue products out of the unit.
5. A pressure switch (Air Proving Switch) is used as a safety device that prevents the ignition system from firing the unit until it senses that a proper draft has been established through the heat exchanger.

SEQUENCE OF OPERATION - HEATING

Refer to the appropriate Ignition control section for unit you are servicing

ELECTRICAL SUPPLY

SUPPLY CIRCUIT

The unit cannot be expected to operate correctly unless it is properly connected (wired) to an adequately sized single branch circuit. Check the Technical Data Section of this manual to determine if your circuit is adequately sized.

WARNING

Electrical shock hazard.

Turn OFF electric power at fuse box or service panel before making any electrical connections and ensure a proper ground connection is made before connecting line voltage.

Failure to do so can result in property damage, personal injury and/or death.

SUPPLY VOLTAGE

Supply voltage to the unit should be a nominal 230 volts. It **MUST** be between 197 volts and 253 volts. Supply voltage to the unit should be checked **WITH THE UNIT IN OPERATION**. Voltage readings outside the specified range can be expected to cause operating problems. Their cause **MUST** be investigated and corrected.

ELECTRICAL GROUND

Grounding of the electrical supply to **ALL UNITS IS REQUIRED** for safety reasons.

CONTROL (LOW) VOLTAGE

The Control (Low) Voltage transformer on most models is equipped with two (2) Primary Voltage taps. In order to insure proper unit operation the transformer secondary output must be maintained at a nominal 24 Volts. Connecting the primary (supply) wire (normally black in color) to the tap (I.E. 208 or 240 Volts) that most closely matches the **MEASURED** supply voltage will insure proper transformer secondary output is maintained.

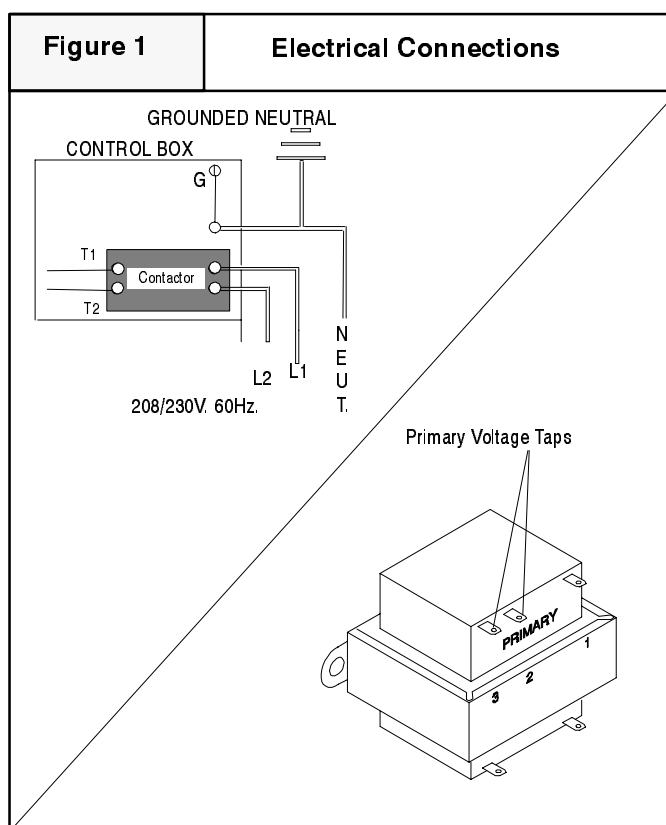

GAS SUPPLY

An adequately sized gas supply to the unit is required for proper operation. Gas piping which is undersized will not provide sufficient capacity for proper operation. Piping should be sized in accordance with accepted industry standards.

NATURAL GAS

Inlet pressure to the unit should be checked (at the gas valve) with **ALL OTHER GAS FIRED APPLIANCES OPERATING**. Inlet pressure to the unit under these conditions **MUST** be a minimum of 4.5 in. W.C. If the inlet pressure is less, it may be an indication of undersized piping or regulator problems.

L. P. GAS

Inlet pressure to the unit should be checked in the same manner as for Natural gas, however, with L.P. Gas, the inlet pressure **MUST** be a minimum of 11 in. W.C. If this cannot be obtained, problems are indicated in either the regulator or pipe sizing.

Figure 2	Gas Pressures	
	Natural Gas	LP Gas
Minimum Inlet	4.5" W.C. (1120 Pa)	11" W.C. (2740 Pa)
Recommended Inlet	7" W.C. (1740 Pa)	11" W.C. (2740 Pa)
Maximum Inlet	13" W.C. (3230 Pa)	13" W.C. (3230 Pa)
Manifold Pressure	3.5" W.C. (870 Pa)	10" W.C. (2490 Pa)

CHECKING INPUT (FIRING) RATE

Once it has been determined that the gas supply (inlet) pressure is correct to the unit, it is necessary to check the input (firing) rate. This can be done in two (2) ways. First (the preferred method) by checking and adjusting (as necessary) the manifold pressure. The second way is to "Clock" the gas meter (on Natural Gas Models).

WARNING

Fire or explosion hazard.

Turn OFF gas at shut off before connecting U-tube manometer.

Failure to turn OFF gas at shut off before connecting U-tube manometer can result in personal injury and/or death.

CHECKING MANIFOLD PRESSURE

1. Connect a U-tube manometer or Magnehelic gauge (0-12 in. W.C. range) to the pressure tap on the "OUTLET" side of the gas valve.

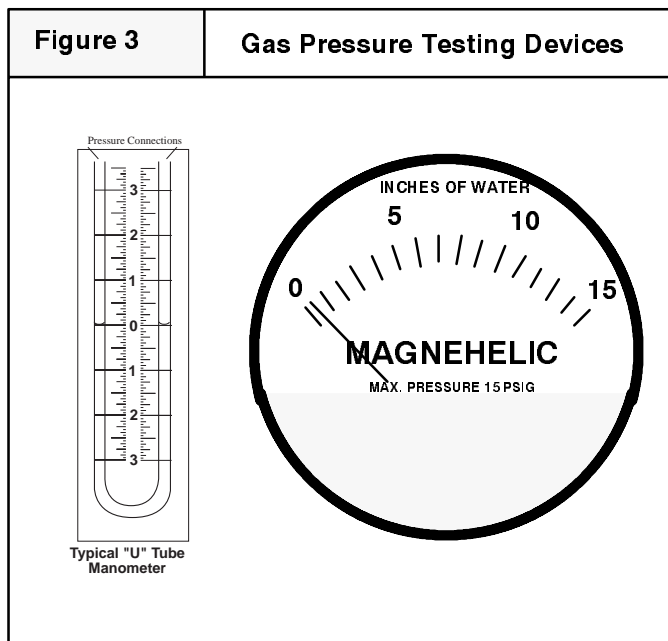

2. Turn gas "ON" . fire the unit, and remove adjustment cover (screw-cap).
3. Turn adjustment screw clockwise (IN) to INCREASE pressure, and counterclockwise (OUT) to DECREASE pressure.

Figure 4 Typical Gas Valve

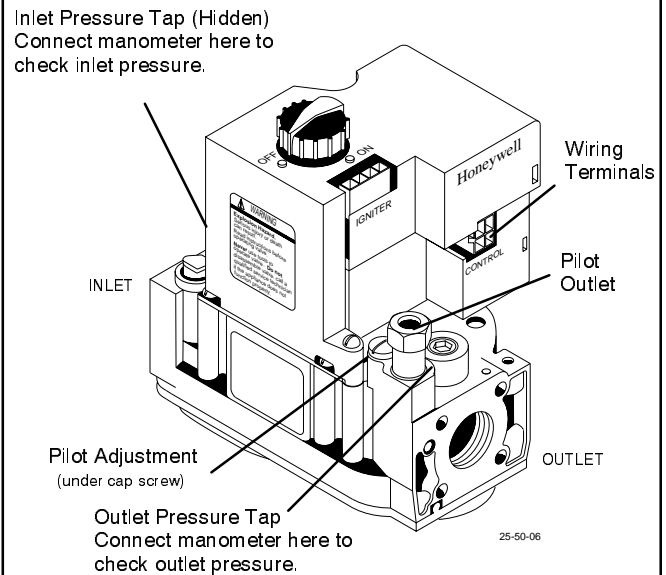

4. Set manifold pressure to 3.5 in. W.C. for Natural Gas, and to 10 in. W.C. for L.P. Gas.
5. For units above 2,000 Ft., insure that orifice size has been changed (per National Fuel Gas Code - Appendix "F") if gas supply has not already been de-rated for altitude by the gas supplier.

"CLOCKING" GAS METER (NATURAL GAS)

1. Check with gas supplier to obtain ACTUAL BTU content of gas.
2. Turn "OFF" gas supply to ALL other gas appliances.
3. Time how many seconds it takes the smallest (normally 1 cfh) dial on the gas meter to make one complete revolution.

Example			
Natural Gas BTU Content	No. of Seconds Per Hour	Time Per Cubic Foot in Seconds	BTU Per Hour
1,000	3,600	48	75,000
1,000 x 3,600 ÷ 48 = 75,000 BTUH			

4. Calculate input rate by using ACTUAL BTU content of gas in formula shown in example.

BURNERS

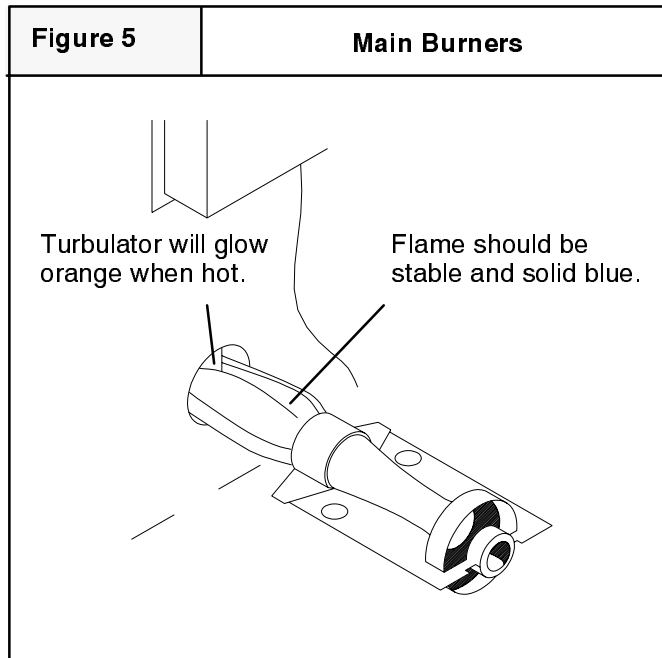

Burners used in this series of unit are of the "INSHOT" type. Their operation can be compared to that of a torch since they produce a hard, sharp, somewhat noisy flame. Proper adjustment of the gas (manifold) pressure is essential, to insure that the burners are operating properly, and at their design noise level,

The burners used in this series ARE NOT EQUIPPED WITH AIR SHUTTERS, as none are required. Proper operation (flame characteristics) is obtained by insuring that the orifice size, and manifold pressure are correct for the fuel being used and the altitude of the installation.

Turbulators are found inside the tube of each section of the heat exchanger of ALL Natural Gas units. On earlier units, it was necessary to remove these turbulators when converting to LP gas since they would not withstand the higher temperature associated with LP. With improvements in turbulator technology, however, more recent units converted to LP will be equipped with turbulators. During burner operation, it is normal for the turbulators to glow orange.

CHECKING TEMPERATURE RISE

The unit is designed to operate within a certain specified range of temperature rise.

Operating the unit outside the specified range may result in lower efficiency and/or comfort levels, as well as premature combustion component failures.

Simply stated, the temperature rise through the unit is the difference in temperature between the return air, and the supply air.

NOTE: BEFORE CHECKING TEMPERATURE RISE BE CERTAIN THAT MANIFOLD PRESSURE IS PROPERLY ADJUSTED

Temperature Rise can be checked by placing a thermometer in the return air duct as close to the unit as possible. Place a second thermometer in the supply duct at least two (2) feet away from the unit. (This will prevent any false readings caused by radiation from the unit heat exchanger) Make sure that the FILTER IS CLEAN and that ALL REGISTERS AND/OR DAMPERS ARE OPEN.

Operate the unit for 15 minutes before taking temperature readings. Subtract the return air temperature from the supply air temperature. The result is the temperature rise. Compare with the allowable rise listed for the model (size) you are checking.

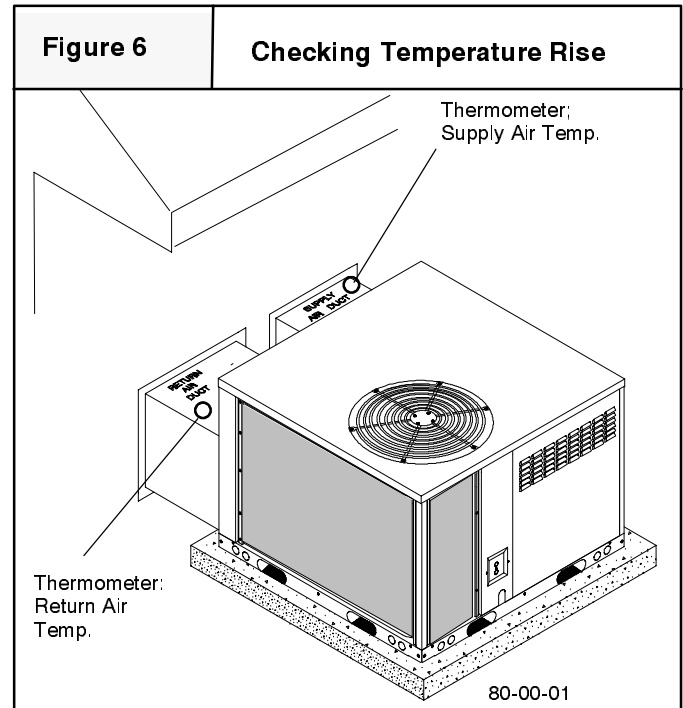

If the rise is not within the specified range, it will be necessary to change the heating blower speed. **If the rise is too high**, it will be necessary to **increase the blower speed**. **If the rise is too low**, it will be necessary to **reduce the blower speed**.

HIGH ALTITUDE OPERATION

This series of unit is designed to operate in the majority of the country without any modifications. Beginning at altitudes of 2,000 Ft. above sea level, however, certain measures need to be taken to insure continued, safe, reliable operation. For example, units must be de-rated for altitude (by changing orifice size) based upon the Btu content of the gas being supplied, and installed altitude.

When servicing a unit installed at altitudes above 2,000

Ft., insure that it has been properly modified to operate at that particular altitude. Check with the Gas supplier to determine if the gas being supplied has already been de-rated for altitude. If not, Consult the National Fuel Gas Code (ANSI Z223.1) Table F-4 to obtain specific information for your particular installation altitude. You may also check the unit's rating plate for a listing of orifice sizes to be used with "standard" 1000 Btu per cubic foot Natural gas at higher altitudes.

ROOM THERMOSTATS

Room thermostats are available from several different manufacturers in a wide variety of styles. They range from the very simple and inexpensive Bi-metallic type to the complex and costly electronic set-back type. In all cases, no matter how simple or complex, they are simply a switch (or series of switches) designed to turn equipment (or components) "ON" or "OFF" at the desired conditions.

An improperly operating, or poorly located room thermostat can be the source of perceived equipment problems. A careful check of the thermostat and wiring must be made then to insure that it is not the source of problems.

LOCATION

The thermostat should not be mounted where it may be affected by drafts, discharge air from registers (hot or cold), or heat radiated from the sun or appliances.

The thermostat should be located about 5 Ft. above the floor in an area of average temperature, with good air circulation. Normally, an area in close proximity to the return air grille is the best choice.

Mercury bulb type thermostats **MUST** be level to control temperature accurately to the desired set-point. Electronic digital type thermostats **SHOULD** be level for aesthetics.

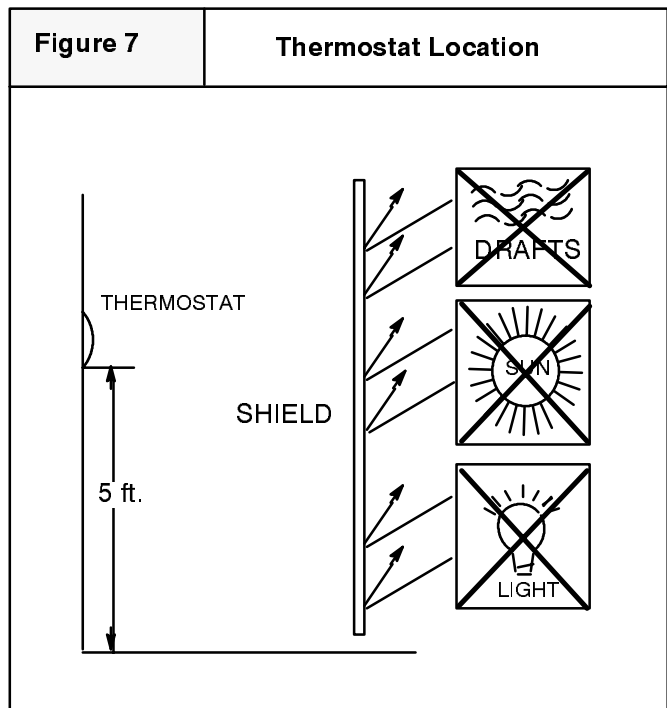

HEAT ANTICIPATORS

Heat anticipators are small resistance heaters built into most electro-mechanical thermostats. Their purpose is to prevent wide swings in room temperature during furnace operation.

In order to accomplish this, the heat output from the anticipator must be the same regardless of the current flowing through it. Consequently, most thermostats have an adjustment to compensate for varying current draw in the thermostat circuit.

The proper setting of heat anticipators then is important to insure proper temperature control and customer satisfaction.

The best method to obtain the required setting for the heat anticipator, is to measure the actual current draw in the control circuit ("W") using a low range (0-2.0 Amps) Ammeter. (See Illustration) After measuring the current draw, simply set the heat anticipator to match that value.

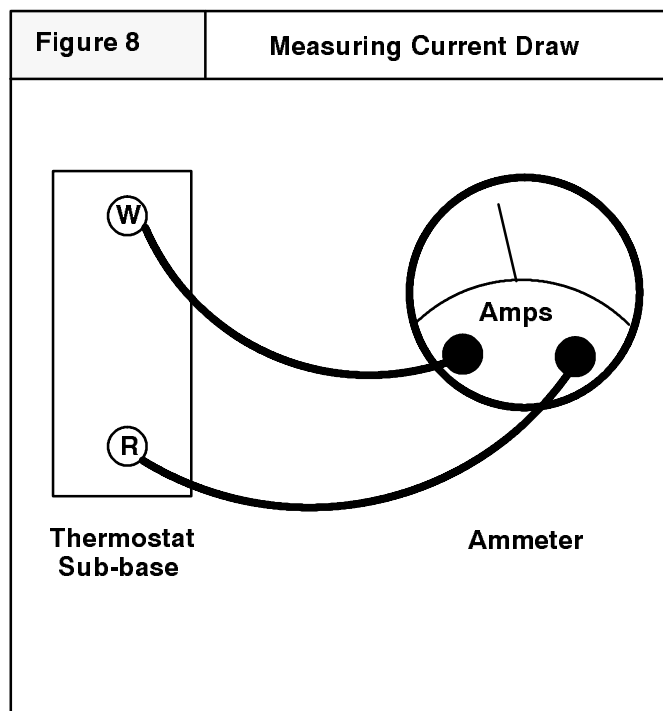

If a low range ammeter is not available, a "Clamp-on" type ammeter may be used as follows:

1. Wrap EXACTLY ten (10) turns of wire around the jaws of a clamp-on type ammeter.
2. Connect one end of the wire to the "W" terminal of the thermostat sub-base, and the other to the "R" terminal.
3. Turn power on, and wait approximately 1 minute, then read meter.
4. Divide meter reading by 10 to obtain correct anticipator setting.

If an ammeter is not available, a setting of 0.75 amps can be used for models equipped with the HONEYWELL S8600 ignition module and a setting of 0.30 amps can be used for models equipped with the HONEYWELL SV9500 Gas Valve/Ignition Control which should provide satisfactory operation in most cases.

Electronic thermostats do not use a resistance type anticipator. These thermostats use a microprocessor (computer) that determines a cycle rate based on a program loaded into it at the factory.

These cycle rates are normally field adjustable for different types of equipment. The method of adjustment, however, varies from one thermostat manufacturer to another. Check with the thermostat manufacturer to find out the proper way of adjusting the cycle rate.

CONTROL WIRING

Control wiring is an important part of the total equipment installation, since it provides the vital communications link between the thermostat, and the equipment. It is often overlooked as the source of equipment malfunctions. Control wiring that is either too long, undersized, or improperly connected (be it simply loose, or on the wrong terminal) can in fact be the source of many equipment problems.

ALWAYS check to make sure that the control wiring is connected to the proper terminal(s) of the equipment and thermostat you are using. Remember, also, that thermostat terminals are not always identified alike by different thermostat manufacturers. Connections MUST be clean and tight to insure trouble-free operation.

ELECTRONIC CONTROLS used on certain models of this series of unit RESPOND DIFFERENTLY than what one may be accustomed to.

For Example:

On earlier models of this series equipped with a HEATCRAFT or WATSCO (Cam-Stat) HEATING fan timer used a separate COOLING fan timer to operate the conditioned air blower in cooling. This COOLING fan timer was energized via the "G" terminal to bring on the cooling speed.

More recent models of this series use the HONEYWELL ST9120 electronic Fan Timer/Furnace Control which contains a built in blower relay.

On these models, The COOLING fan speed is energized via the "Y" terminal. The HEATING speed will be energized via the "G" terminal

For more detailed information about this control, see the appropriate section on the ST9120 control, found elsewhere in this manual.

LIMIT SWITCHES

Two (2) different kinds of limit switches are used on this series of Packaged Gas/Electric Unit. They are the main limit and the roll-out limit. The main limit and roll-out limit switches are used on ALL models.

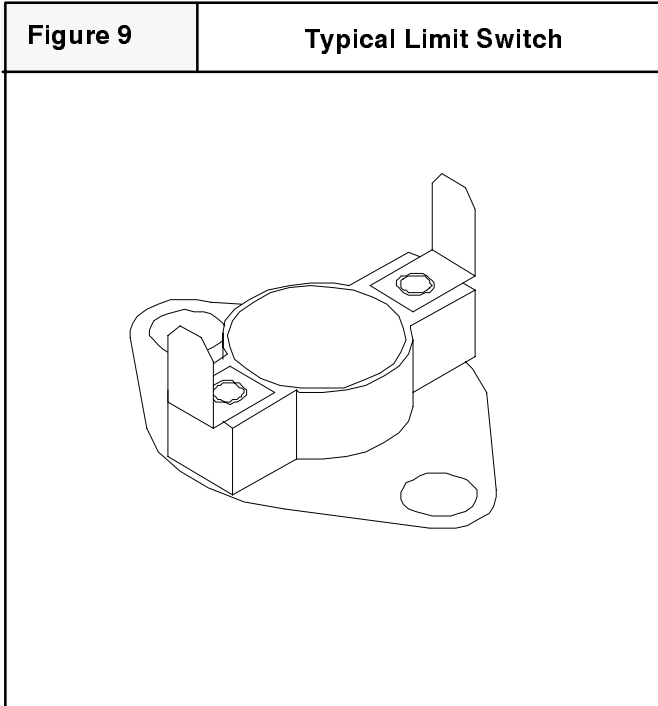

It must be remembered, that a **limit switch** is a **safety device** and other than for testing purposes, **limit switches should never be jumped out**. Limit switches are "normally closed" electrical switches that are designed to open when their pre-determined "limit setting" has been reached. It should also be remembered, that when a limit switch opens, it more than likely is not due to a bad switch!

The cause of the opening limit must be found and corrected, before the furnace can resume proper operation.

WARNING

Fire hazard.

Limit controls are factory preset and MUST NOT be adjusted. Use ONLY manufacturer's authorized replacement parts.

Failure to do so can result in personal injury and/or death.

The specific functions of the two (2) limit switches used in this series of Packaged Gas/Electric Unit is as follows.

MAIN LIMIT SWITCH

A "Normally Closed" switch located on the blower deck of the unit. Its purpose is to monitor supply air temperature, and to interrupt furnace (burner) operation when a supply air temperature is sensed which would result in the furnace exceeding Maximum allowable outlet air temperature. While the main limit is open, (depending upon the model) the combustion blower, and/or the circulating blower may be energized continuously. This control is an "Automatic" re-set control, which will re-set itself when the temperature sensed drops to a safe level.

If furnace (burner) cycles on this limit switch, (I.E. switch opens and closes during furnace operation) it is more than likely due to a high temperature rise through the furnace. (See checking temperature rise found elsewhere in this manual)

High temperature rise can be caused by either OVER-FIRING (high manifold pressure, incorrect orifices, etc.) or LOW AIR FLOW (dirty filter, blower speed too low, excessive static in duct system, etc.)

To verify this, the cut-out (opening) point of the switch should be checked (using a thermocouple type thermometer connected to the switch) as follows:

1. Operate furnace for several minutes.
2. Block return air grille(s) to furnace.
3. Observe temperature at which switch opens (burner operation ceases).
4. Remove blockage from return grille(s).
5. Observe temperature at which switch closes (burner operation resumes).
6. Compare readings with the limit setting listed in the Tech. Service Data section for the model you are servicing.

If switch is opening within the specified range, then it is simply doing its job, and the cause of the over-temperature must be determined and corrected.

If, however, the switch is found to be opening prematurely, then it should be replaced. When replacing ANY limit switch, use ONLY a switch of EXACTLY the same temperature setting. Use of a different temperature limit switch can create a dangerous situation. Some of the main limit switches used in this series are SIMILAR IN APPEARANCE, however, DIFFERENT TEMPERATURE SETTINGS ARE USED

for different models. Be certain you have the correct control for the model you are servicing.

ROLL-OUT LIMIT SWITCH

A "Normally Closed" switch mounted on the top of the burner box. The purpose of the roll-out switch(es) is to monitor the temperature inside the burner box, and to interrupt furnace (burner) operation when a temperature is sensed that indicates flame roll-out has taken place.

All models are equipped with a manual re-set roll-out switch. Once the roll-out switch has opened, burner operation will be prevented until the roll-out switch is "Manually Re-set" by pressing the red button located on the switch. While the roll-out switch is open, (Depending upon the particular model) the combustion blower and/or circulating blower may be energized continuously.

NEVER USE AN AUTOMATIC RE-SET ROLL-OUT SWITCH TO REPLACE A MANUAL RE-SET TYPE ROLL-OUT SWITCH.

If the roll-out switch has opened, the cause must be determined. A restricted heat exchanger or over-fired furnace are some possible reasons for flame roll-out.

Figure 10

Typical Roll-out Limit Switch

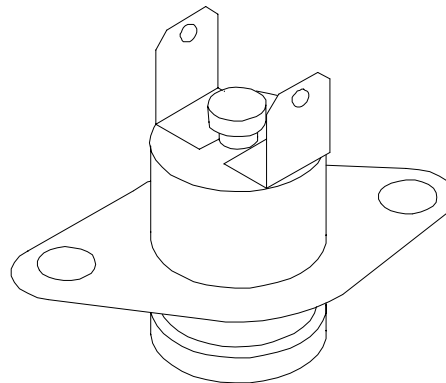

PRESSURE SWITCHES

An air proving switch (pressure switch) is used on all models to insure that a draft has been established through the heat exchanger before allowing burner operation.

All Models models use a single tap (port) switch which senses the negative pressure that is created by (at) the combustion blower, and is present inside the heat exchanger of the furnace.

Figure 11

Pressure Switch

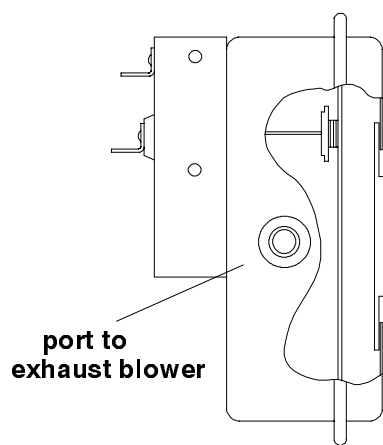

All Models use the same (setting) "Normally Open" pressure switch. The particular setting is required to insure continued SAFE, RELIABLE, operation. NEVER SUBSTITUTE a pressure switch with one that is similar in appearance. ONLY FACTORY PROVIDED or AUTHORIZED SUBSTITUTES ARE ACCEPTABLE.

If you are servicing a unit whose pressure switch will not close, or remain closed during operation, the operating pressure of that unit should be checked and compared to the switch setting. The switch closes at a $-.175" \pm .070"$ W.C. The switch opens at a differential (difference in pressure from closing point) of $.015"$ W.C.

Under normal operating conditions, sufficient negative pressure will be created to close the pressure switch, and keep it closed to keep the furnace section operating. Under abnormal conditions, however, such as a restricted vent (flue exhaust hood), or a leak in the heat exchanger, sufficient negative pressure will not be created. This will result in the switch failing to close or failing to remain closed during furnace section operation.

EXHAUST BLOWER

All models use the same induced draft combustion blower mounted on the outlet side of the heat exchanger. The purpose of the combustion blower is to establish a draft (flow) through the heat exchanger, to insure that all flue products are carried outside the unit via the flue exhaust hood.

There is a pressure tap on the blower housing which connects (via a silicone rubber tube) to the tap on the unit's pressure switch. During normal operation the exhaust blower develops sufficient negative pressure to close the pressure switch and keep it closed.

The blower housing is made of metal, and is driven by a 230 Volt shaded pole motor. Basically there are only two problems that can be experienced with this component. It can have a motor failure, or it can become noisy due to bad bearings, loose wheel, etc.

Although some parts lists show a component breakdown for the exhaust blower (i.e. blower housing, motor, and wheel) The exhaust blower is normally serviced as an assembly. When servicing the assembly be certain to insure that gaskets are replaced (or in good condition). Leaking gaskets can cause operational problems, such as the pressure switch not closing.

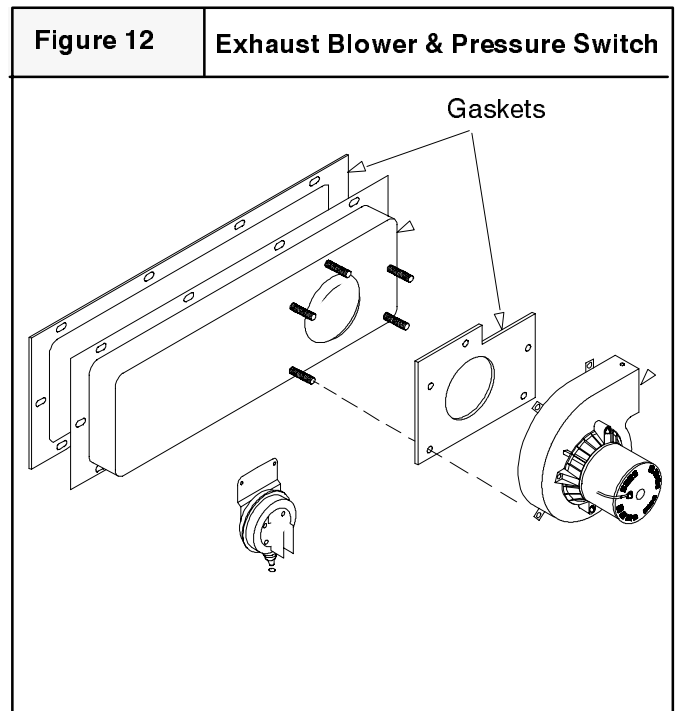

CAPACITORS

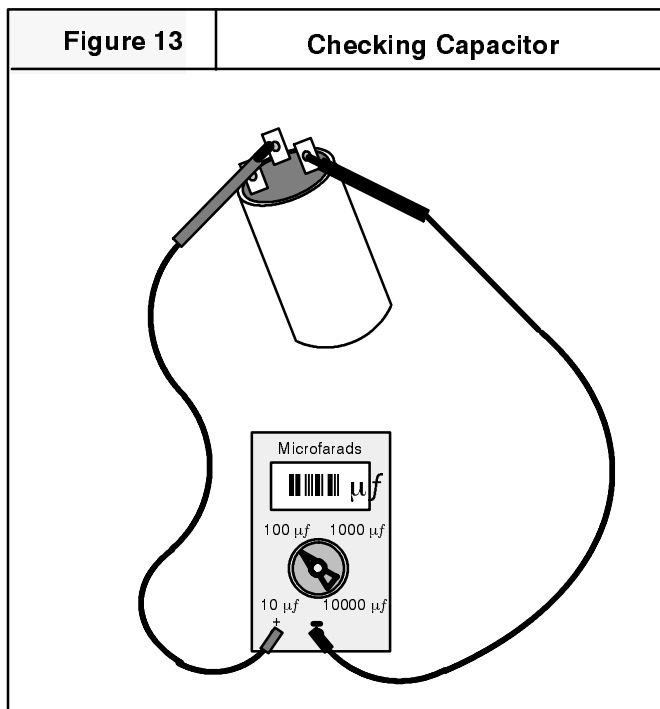

Capacitors are used for the circulating (conditioned air) blower, the condenser fan motor, and the compressor. Before replacing one of these components (assumed to be bad) the condition of its capacitor should be verified, since it, and not the motor may be the source of the problem.

Before checking **any** capacitor, the supply power to the unit should be turned "OFF".

The capacitor should then be discharged (through a resistor) before testing. A 20,000 Ohm 2 Watt resistor can be used for this purpose.

The condition of the capacitor should be verified with a capacitor analyzer (one that indicates the capacitor's value in microfarads) rather than with an Ohmmeter. The reason for this, is that an Ohmmeter test can only indicate if a capacitor is "OPEN, or "SHORTED", it cannot verify if its value (microfarads) is within an acceptable range.

Capacitor should test to within 10% of its rated value. Capacitors testing outside this range should be replaced. A Weak capacitor can be the cause of a motor failing to start, or failing to run at proper speed.

HEATCRAFT & WATSCO (CAM-STAT) ELECTRONIC HEATING FAN TIMERS

One of two (2) different electronic (HEATING) fan timers may be found in most earlier models. Although different in physical appearance, they both function identically. They provide an adjustable "ON" delay in HEATING of 15-90 seconds, and an adjustable "OFF" delay in HEATING of 30-120 seconds. Due to the manner in which they are wired into the circuit, they will also provide a continuous blower operation whenever one of the safeties (limit switches) is open with the furnace powered.

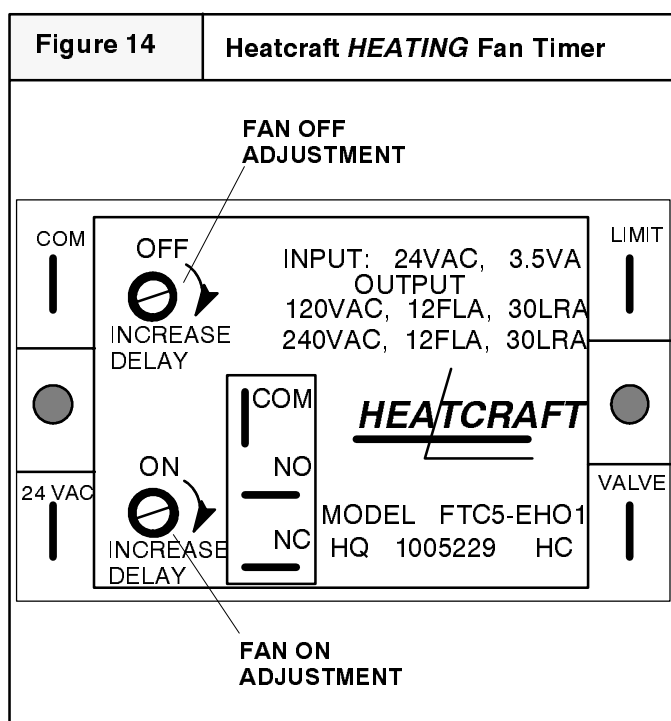

Although the controls operate identically, some replacement controls may have terminals located and/or identified differently. Always be certain when replacing a control to wire according to terminal identification, NOT according according to terminal location.

CONTROL OPERATION

In order for this control to function properly, it **MUST** be wired into the circuit correctly. The first step then in checking this control is to insure that it is wired according the unit's wiring diagram.

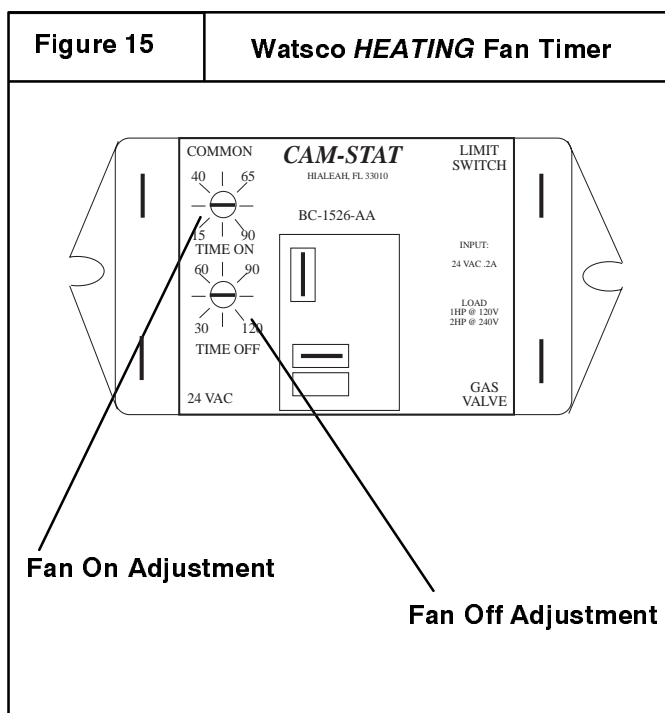

There are four (4) **low voltage** terminals located around the outside perimeter of the control. The "COM" terminal is always connected to the Common side of the 24 Volt power supply. The "24 VAC" terminal and "LIMIT" terminal (all limit switches are in series with the "HOT" ("R") terminal) are always connected to the "HOT" ("R") side of the low voltage transformer. The "VALVE" terminal is always connected to the gas valve terminal that is energized on a call for heat.

There are two (2) **line voltage** terminals in the center of the control marked "COM and "NO" (some controls may have a third terminal marked "NC", however it is not used in this application of the control) The "COM" line volt terminal is connected to the "NC" terminal of the *COOLING* fan timer (to supply line voltage power) whereas the "NO" terminal is connected to the HEATING blower speed tap.

When wired as indicated, (and with the furnace connected to line voltage) the control will function as follows:

If the power (lead) is removed from the "LIMIT" terminal, The "Normally Open" fan contacts will close and immediately bring on the blower. (This is what happens when one of the limit switches opens) The blower will continue to run as long as this circuit remains open. Once the the circuit is closed, and 24 volt power is reapplied to the "LIMIT" terminal the "OFF" delay will be initiated, and when complete, the blower will turn off.

Normal fan timing ("ON and "OFF" delays) is initiated whenever the "VALVE" terminal is energized (or de-energized in the case of "OFF" delays) with 24 volts, as is the case when the gas valve opens and closes.

CHECKING HEATCRAFT AND/OR WATSCO HEATING FAN TIMERS

The control may be checked while it is in the furnace as follows.:

Turn Electrical and Gas supply off to furnace.

WARNING

Electrical shock hazard.

Turn OFF electric power at fuse box or service panel before making any electrical connections and ensure a proper ground connection is made before connecting line voltage.

Failure to do so can result in property damage, personal injury and/or death.

To check the "ON" delay place a jumper wire between the "24VAC" and "VALVE" terminals. Restore ELECTRICAL power. After "ON" delay (15-90 seconds) expires, "NORMALLY OPEN" fan contacts should close, and blower should run.

To check "OFF" delay, CAREFULLY remove jumper wire from between "24VAC" and "VALVE" terminals (remembering that FURNACE IS STILL POWERED). After "OFF" delay (30-120 seconds) expires, "NORMALLY OPEN" contacts should reopen, and blower should stop.

To check the "LIMIT" function carefully (with the unit still powered) disconnect the wire to the "LIMIT" terminal (or a wire to ANY of the limit switches in furnace). The blower should start immediately, and continue to run as long as wire is disconnected. Upon reconnecting the wire, the control will go through a normal "OFF" delay (30-120 seconds) after which time, the blower should stop.

If the control passes these tests it is operating normally. Restore Gas and Electrical supply, and resume operation.

HEATCRAFT & WATSCO (CAM-STAT) ELECTRONIC COOLING FAN TIMERS

One of two (2) different electronic (COOLING) fan timers may also be found in most earlier models. Although similar in physical appearance to the heating fan timers described in the previous section, their timings are fixed, and not adjustable. They provide a fixed (non-adjustable) "ON" delay in COOLING of 30 seconds, and a fixed (non-adjustable) "OFF" delay of 30 seconds.

Although the different cooling fan timers operate identically, some replacement controls may have terminals located and/or identified differently. Always be certain when replacing a control to wire according to terminal identification, NOT according according to terminal location.

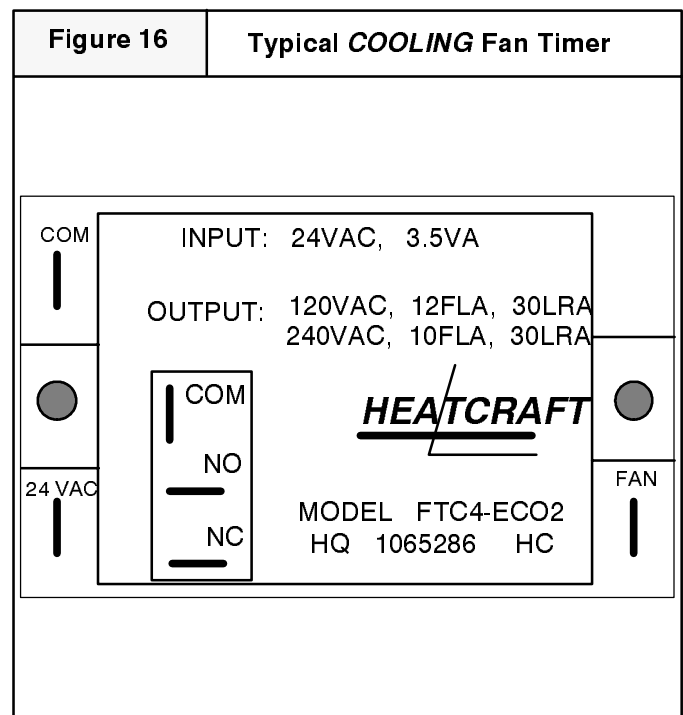

CONTROL OPERATION

In order for this control to function properly, it **MUST** be wired into the circuit correctly. The first step then in checking this control is to insure that it is wired according to the unit's wiring diagram.

There are three (3) **low voltage** terminals located on the outside perimeter of the control. The "COM" terminal is always connected to the Common side of the 24 Volt power supply. The "24 VAC" terminal is always connected to the "HOT" ("R") side of the low voltage transformer. The "FAN" terminal is connected to the "G" terminal of the low voltage terminal strip. This is the terminal that is energized by the thermostat on a call for fan operation.

There are also three (3) **line voltage** terminals in the center of the control marked "COM", "NO" and "NC". The "COM" line volt terminal is connected to the primary "Line" side of the low voltage transformer. The "NO" terminal is connected to the COOLING speed tap wire of the blower motor. The "NC" terminal is connected to "COM" terminal of the HEATING fan timer providing it with its line voltage power supply.

When wired as indicated, (and with the unit connected to line voltage) the control will function as follows:

Fan timing ("ON" and "OFF" delay) is initiated whenever the "FAN" terminal is energized (or de-energized in the case of "OFF" delay) with 24 volts, as is the case when the THERMOSTAT calls for COOLING energizing the "Y" & "G" terminals. The "G" terminal may also be energized on some thermostats by moving the "FAN" selector switch to the "ON" position.

HONEYWELL ST9120 Series FAN TIMER/FURNACE CONTROL

The HONEYWELL ST9120 Electronic Fan Timer/Furnace Control is an integrated electronic control, which contains **NO USER SERVICEABLE COMPONENTS**. It is, as its name implies, a fan timer and a furnace control of sorts. In addition to controlling the fan operation for **BOTH HEATING and COOLING**, it also takes the place of the combustion air relay and/or the system relay.

Two (2) different series of the control (ST9120"C" & ST9120"G") may be encountered in this series of product. The operation of both versions is identical. The basic difference between these versions is that one has a black plastic enclosure, whereas the other does not. They both provide for field adjustment of the "ON" and

CHECKING HEATCRAFT AND/OR WATSCO COOLING FAN TIMERS

The control may be checked while it is in the unit as follows.:

Turn Electrical supply off to unit

WARNING

Electrical shock hazard.

Turn OFF electric power at fuse box or service panel before making any electrical connections and ensure a proper ground connection is made before connecting line voltage.

Failure to do so can result in property damage, personal injury and/or death.

To check the "ON" delay place a jumper wire between the "24VAC" and "FAN" terminals. Restore ELECTRICAL power. After "ON" delay (30 seconds) expires, "NORMALLY OPEN" fan contacts should close, and blower should run.

To check "OFF" delay, CAREFULLY remove jumper wire from between "24VAC" and "FAN" terminals (remembering that the UNIT IS STILL POWERED). After "OFF" delay (30 seconds) expires, "NORMALLY OPEN" contacts should reopen, and blower should stop.

If the control passes these tests it is operating normally. Restore Electrical supply, and resume operation.

"OFF" delays in HEATING, as well as providing FIXED (non-adjustable) "ON" and "OFF" delays in COOLING. For replacement parts purposes, only the ST9120G (with black plastic enclosure) is supplied.

The ST9120 is used in more recent models in conjunction with the SV9500 GAS VALVE/IGNITION CONTROL. It provides the power source to begin the ignition sequence through a monitored safety circuit. It also serves as a low voltage terminal strip. In the ST9120 series control certain accessory terminals are also provided as well as a Continuous fan terminal which allows for continuous fan operation at a speed other than either the heating or cooling speed.

Figure 17

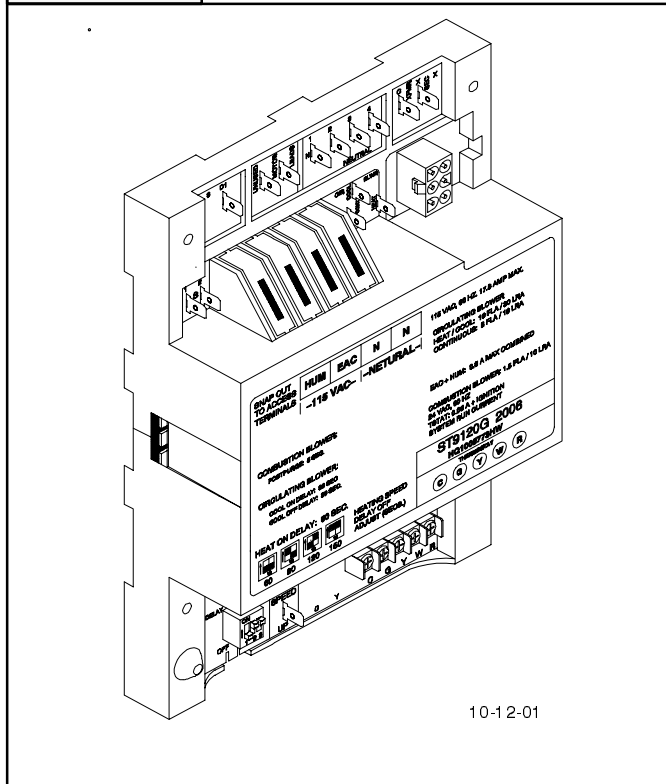
Honeywell ST9120G
(with enclosure)

The control provides a fixed (non-adjustable) 30 second "ON" and "OFF" delay for the circulating blower in COOLING and an adjustable 30 or 60 second "ON" delay for the circulating blower in HEATING.

The ST9120 control also provides an adjustable HEATING "OFF" delay for the circulating blower which can be field adjusted to 60, 90, 120, or 150 seconds (60,100,140, or 180 on newer controls).

HONEYWELL ST9120 UNIQUE CONTROL FUNCTIONS/RESPONSES

There are some unique responses from these controls that differ from what one would normally expect, and may be somewhat confusing. Specifically, these are as follows:

Energizing the "G" terminal of this control will cause the blower to run on the HEATING speed. (With most other furnaces, a blower relay is normally energized via the "G" terminal causing the blower to run on the cooling speed.)

Energizing the "G" & "Y" terminals (together) will cause the blower to run on the COOLING speed. It is important that you take note of this, since control wiring improperly connected can cause perceived as well as real equipment problems.

"NO TERMINALS" ENERGIZED (on low voltage terminal strip) - If a speed tap wire has been connected to the "CONT" (continuous) terminal, (optional terminal provided on the ST9120 series controls) the blower will run on this speed. Maximum allowable connected load for this terminal is 8.0 FLA

This feature requires some explanation as to how it differs from "FAN ON" selected from the thermostat sub-base.

The "CONTINUOUS" terminal of the ST9120 control is energized **ONLY** when there is NO OTHER CALL FOR OPERATION of any kind. If there is a call for HEAT, COOL, or "FAN ON", this terminal is DE-ENERGIZED. The purpose of this terminal is to provide a means of air circulation during "OFF CYCLES" at a different speed than either heating or cooling. **The use of this terminal is optional, and there will be no speed tap wires connected to this terminal when the unit is shipped.**

Figure 18

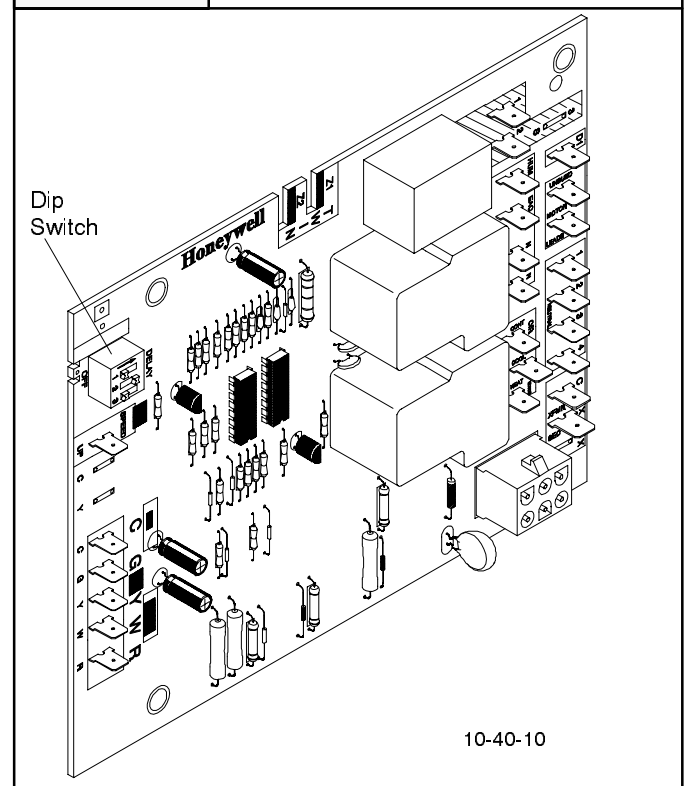
Honeywell ST9120C
(without enclosure)

"CONTINUOUS" fan should not be confused with "FAN ON" which is obtained by switching the fan selector switch on the thermostat sub-base to "FAN ON" (energizing the "G" terminal) which causes the blower to run on the "HEATING" speed.

The **ST9120 Electronic Air Cleaner terminal (EAC)** IS **ONLY** energized in conjunction with the HEATING and COOLING speed terminals. It IS NOT ENERGIZED in conjunction with the "CONTINUOUS" fan speed terminal.

The maximum allowable connected load to the EAC terminal is 0.8 (eight tenths) Amp.*

The ST9120 HUMIDIFIER terminal (HUM) is energized in conjunction with terminal "D1" (I.E. it is energized whenever the combustion blower is running) The maximum allowable connected load to the HUM terminal is 0.8 (eight tenths) Amp.*

The combined connected loads of the EAC and HUM terminals cannot exceed a total of 0.8 (eight tenths) amp.

Setting The ST9120 Heating Fan "OFF" Delay is accomplished by the positioning of "DIP" switches. The illustration below, as well as a label on the control itself indicates how to position these switches to obtain the desired setting.

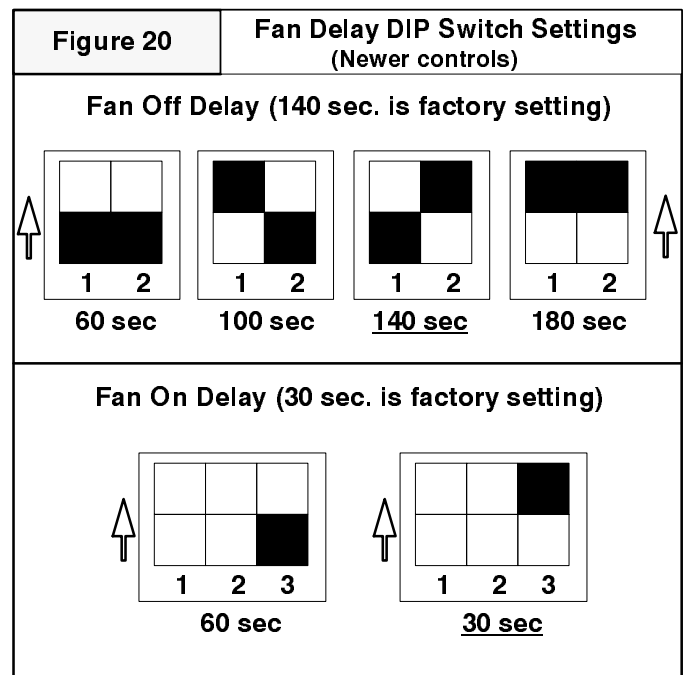
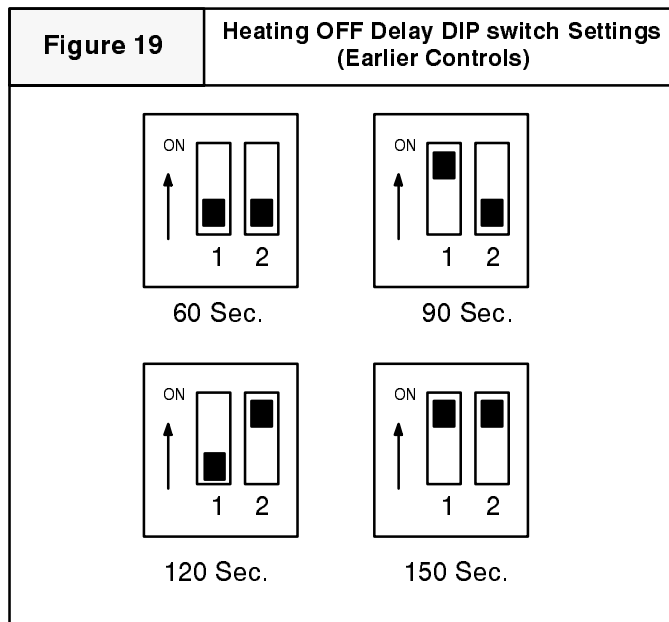

The ST9120 Heating "OFF" delay can be set to either 60, 90, 120, or 150 seconds (60, 100, 140, or 180 for newer controls). The control was shipped out in the 120 second position (140 for newer controls). This may be satisfactory for some installations, but not for others.

The "OFF" delay should be set as long as possible without creating "COLD AIR" complaints at the end of the cycle.

The Heating "ON" delay may be set to either 30 or 60 seconds. The control is shipped out at 30 seconds. As with the "OFF" delay, this may be satisfactory for some installations, but not for others.

The "ON" delay should be set as short as possible without creating "COLD AIR" complaints at the beginning of the cycle.

The COOLING "ON and "OFF" delays of the ST9120 series controls are fixed at 30 seconds, and are not adjustable.

The operation of the HONEYWELL ST9120 series FAN TIMER/FURNACE CONTROL (as well as the operation of the unit in general) can be verified in a few minutes by using two (2) jumper wires (to jumper terminals of the low voltage terminal strip) and the "TEST SEQUENCE" below.

ST9120 TESTING SEQUENCE

If unit successfully passes this testing sequence, it can be assumed that there are no problems with the ST9120 FAN TIMER/FURNACE CONTROL. If it does not, however, it does not necessarily mean that there are problems with the control. Any malfunctions should be thoroughly investigated before replacing any components.

CHECKING COOLING FUNCTIONS

1. JUMPER "Y" & "G" TO "R"
2. CHECK FOR COMPRESSOR START-UP
3. CHECK COOLING FAN DELAY "ON"
4. CHECK COOLING SPEED FAN OPERATION
5. REMOVE JUMPER
6. CHECK FOR COMPRESSOR SHUT-DOWN
7. CHECK COOLING FAN "OFF" DELAY

CHECKING HEATING FUNCTIONS

1. JUMPER "W" TO "R"
2. CHECK COMBUSTION BLOWER START-UP
3. CHECK IGNITION SYSTEM ACTIVATION
4. WHEN MAIN BURNER LIGHTS, CHECK HEATING FAN "ON" DELAY
5. CHECK HEATING SPEED FAN OPERATION
6. REMOVE JUMPER
7. CHECK POST PURGE DELAY
8. CHECK HEATING FAN "OFF" DELAY

GAS VALVE/IGNITION CONTROL (HONEYWELL SV9500)

The system consists basically of only two (2) components. The Ignition System Control and the Pilot Hardware. They operate on Two (2) 24 volt power circuits received from the ST9120 Fan Timer/Furnace Control. One is the power supply for the ignitor, the second is to activate the ignition sequence.

The Ignition System Control manages the Ignition Sequence, and the flow of gas to the pilot and main burners. It is in essence a combination Gas Valve and Ignition control. It contains sophisticated electronic components (internally) and has **NO USER SERVICEABLE COMPONENTS**. Should a problem be verified internally within the device, **IT IS NOT FIELD REPAIRABLE**, and must be replaced.

The Pilot Hardware includes the pilot burner, the hot surface element that lights the pilot burner, the flame rod that senses pilot flame, and the cable that attaches to the system control. The hot surface element is made of a tough *break resistant* ceramic composite material. It operates on 24 Volts A.C. The Igniter/Flame Rod assembly can be replaced independently from the pilot burner assembly.

The system operation is quite simple, and forgiving. (I.E. nuisance lockouts are eliminated). A sequence of operation flow chart can be found on page 140.

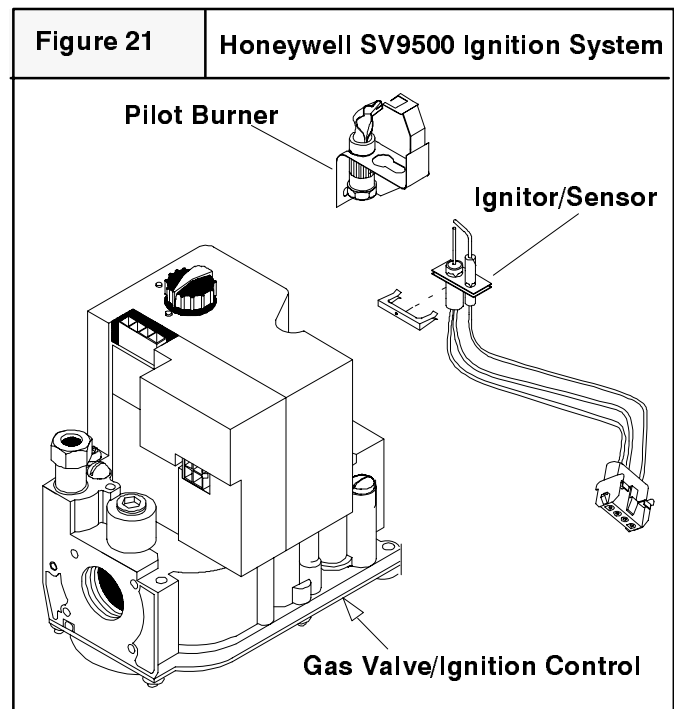

SV9500 SYSTEM OPERATION

Connecting the unit to the line voltage supply provides 24 volts to power the system. (this is accomplished by the connections from terminals [pins] #4 & #2 from the ST9120 fan timer to terminals #1 & #3 of the SV9500 gas valve)

When the thermostat calls for heat, (the combustion blower starts, causing the pressure switch to close completing the circuit to the ignition system control) there will be approximately a two (2) second delay, while the ignition system control runs a self check

Part of that self check is to see if a flame signal is detected. If a flame signal is detected upon a call for heat (and naturally there shouldn't be), the ignition system control will energize the electronic fan timer output (causing the conditioned air blower to start after the fixed 60 second "ON" delay) and will keep the valve and ignitor circuits off.

Assuming that no flame signal is detected upon the call for heat, (Normal operation), the ignition system control will power the ignitor circuit (24 Volts) causing the ignitor to heat up.

If the ignitor circuit is not proven (I.E. the ignitor is missing, broken, or the connections are loose) there will be no response from the ignition system control. (Lockout)

Once the ignitor circuit has been proven, and the ignitor begins to heat up, the pilot valve will be energized allowing gas to flow to the pilot burner.

With the ignitor now hot, and gas flowing to the pilot, the pilot should light, and the sensor should sense flame.

If no flame is sensed, (I.E. no gas, pilot not lit, flame not enveloping sensor, etc.) the ignitor will stay on, and the pilot valve will remain open until it does sense flame, or until the call for heat is satisfied. THE SYSTEM WILL NOT LOCK OUT under this condition.

Assuming that the pilot does light, and flame is sensed, (normal operation) the ignition system control will turn the ignitor off, while energizing the main valve. This will allow the pilot to light the main burner. It will also energize the electronic fan timer output (causing the conditioned air blower to start after the fixed 60 second "ON" delay).

If a flame outage (I.E. loss of gas supply, blown out, etc.) should occur during a run cycle (Main burner operation),

the ignition system will immediately de-energize the main valve and re-power the ignitor circuit placing the system back in to the "Trial For Ignition" mode.

As previously, it will remain in this "Trial For Ignition" mode (Ignitor powered and pilot valve open) either until the pilot lights and flame is sensed, or until the call for heat ends.

If, during main burner operation, the ignitor circuit opens, (I.E. ignitor breaks, or wiring becomes disconnected or loose from control) the pilot and main valve will close and the system will shut down. (Lockout)

Consequently, as you can see, the only condition that will cause a lockout in this system is an unproven ignitor circuit.

With any other type of condition, (loss of gas, loss of power, etc.) the system will reset itself, and revert to a "Trial For Ignition" mode until it either lights and resumes main burner operation, or the call for heat ends.

The SV9500 system is **not sensitive** to furnace grounding or line voltage polarity. Accordingly, you cannot experience a lockout due to those reasons.

Assuming that the main burner did not experience any problems during the run cycle (normal operation) it would continue to operate as long as the call for heat remained.

Once the call for heat ended, the ignition system control would immediately close the main and pilot valves, and de-energize the electronic fan timer output.

De-energizing the electronic fan timer output causes the "OFF" delay timing to begin, and when the pre-selected time (60,90,120, or 150 seconds) expires, the blower will turn off.

TROUBLESHOOTING

Malfunctions of the HONEYWELL SV9500 "Smart Pilot" system may be easily diagnosed using a voltmeter and a spare igniter/flame rod assembly. The igniter itself can also be checked using an Ohmmeter. Resistance of a "Good" igniter should be 10 Ohms or less. See the troubleshooting flow chart and the sequence of operation flow charts on pages 140 & 141 of this manual for additional information on operation and troubleshooting.

HONEYWELL S8600M (SPARK -to- PILOT) IGNITION SYSTEM

Earlier models used a HONEYWELL S8600M spark to pilot ignition system in conjunction with a VR8204 gas valve.

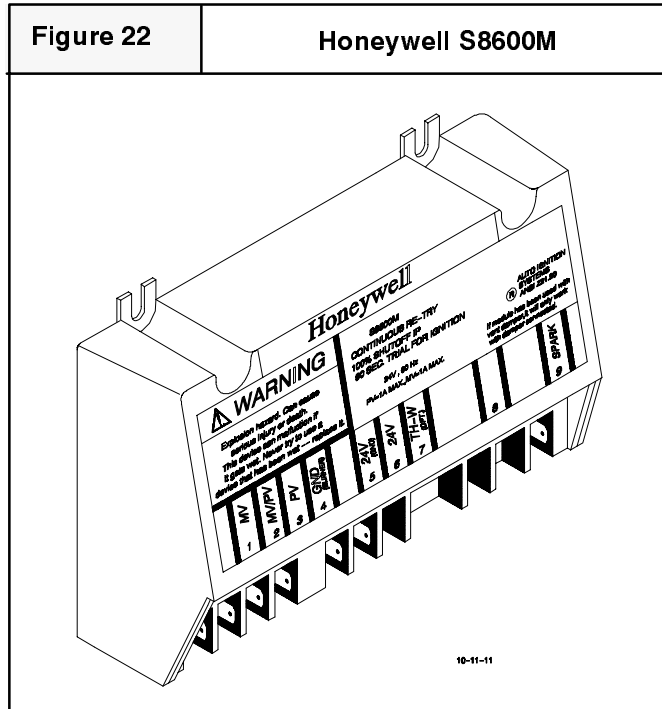

OPERATION

On a call for HEAT, the S8600M is energized (once the pressure switch closes) and provides a 90 second "Trial For Ignition". This "Trial for Ignition" provides a high voltage spark (approximately 20,000 Volts) to the ignitor, and energizes the pilot circuit of the gas valve.

With spark and gas now available at the pilot burner, the pilot should light and prove flame by flame rectification on the flame sensor.

When the S8600M detects the flame rectification of the proven pilot flame, it will simultaneously turn off the spark, and energize the main valve. This will allow the pilot light to light the main burner.

If for some reason the pilot does not light, (I.E. no gas or no spark) or if it lights but does not prove flame (rectification) within the 90 second "Trial for Ignition", the pilot circuit and spark will be de-energized for a "Wait Cycle" of approximately five (5) minutes.

The purpose of the "Wait Cycle" is to allow any unburned gasses to be vented out the flue before once again

providing a "Trial for Ignition". During this five (5) minute "Wait Cycle", apparently nothing will be happening. The combustion blower, however, will be running, and (assuming the pressure switch is closed), the the S8600M will remain energized. The gas valve and/or spark, however, will not be energized during this "Wait Cycle" period.

Once the "Wait Cycle" is complete, the S8600M will provide another 90 seconds "Trial for Ignition". The S8600M will continually repeat this sequence (I.E. 90 second "Trial for Ignition" followed by a Five (5) minute "Wait Cycle") until the pilot and main burner light, or the call for HEAT ends.

During troubleshooting, the "long" five (5) minute "Wait Cycle" can be eliminated by simply satisfying the call for HEAT, and recalling, or by breaking and remaking the line voltage power to the unit. This will reset the S8600M, and immediately provide another 90 second "Trial for Ignition".

TROUBLESHOOTING

Malfunions of the HONEYWELL S8600M "Spark to Pilot" may be easily diagnosed using a Volt-Ohmmeter. See the troubleshooting flow chart in the back pages of this manual.

PILOT ADJUSTMENT (All Models)

Pilot flame adjustment is the same for all models, regardless of which ignition system is used. The pilot flame should be adjusted to envelop flame sensor as shown in Figure 23. Turn pilot adjustment screw COUNTERCLOCKWISE (out) to INCREASE and CLOCKWISE (in) to DECREASE.

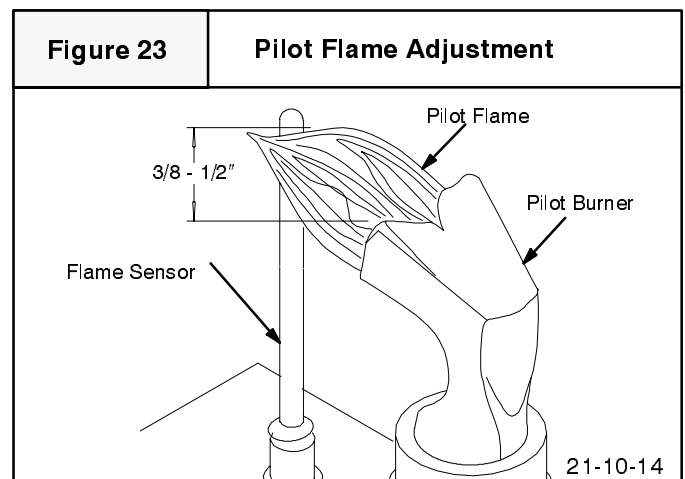

BLOWER ASSEMBLY

All models use a multi-speed, permanent split capacitor motor, direct-drive, blower assembly. Different size (HP) motors and/or different diameter blower wheels are used in each model to obtain the required air flow. There are two (2) methods for accessing the blower motor/assembly for servicing. The method you use will depend on which you prefer, and whether or not you need to remove the wheel and/or housing from the unit. For removal of the entire assembly from the unit, it is necessary to use method 2 described below.

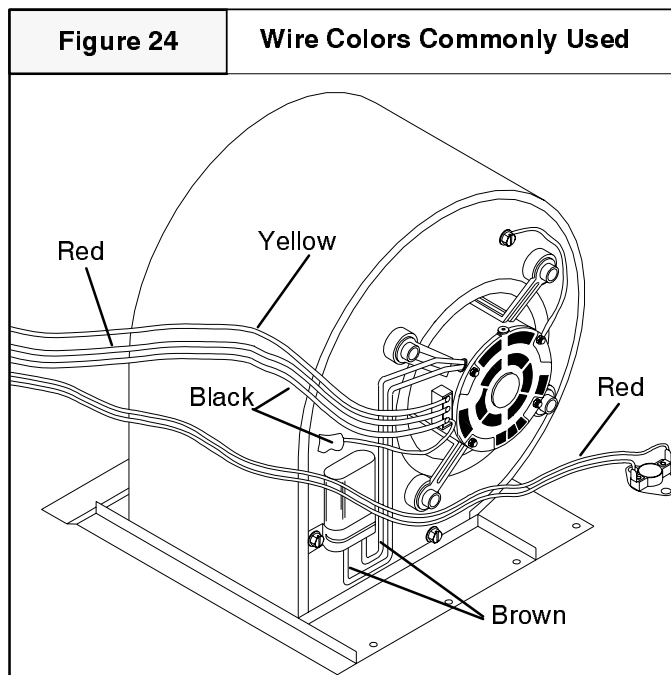

Method 1 Motor removal and replacement

This method allows you to remove and/or replace the motor while the housing and wheel remain in the unit. Some technicians, however, may prefer to work on the entire assembly removed from the unit. If this is your preference, use method 2.

1. Remove the blower access panel
2. Remove the four screws securing the blower housing. If unit has a support bracket, remove the two screws securing the bracket.
3. Remove the two red wires attached to the limit switch.
4. Slide entire housing toward you. This will allow easier access to the speed tap block, motor, and wires.
5. To replace motor, reach behind blower housing and locate blower wheel set screw.

6. Loosen set screw, all wires from motor, and remove four pins on mounting cradle, then pull motor towards you.
7. To replace motor, reverse this procedure.
5. After replacing motor, reconnect all wires, reinstall housing and screws.

Blower wheel inspection

Visually inspect the blower wheel for accumulations of dirt or lint since they can cause reduced airflow. Clean the blower wheel of these accumulations. If accumulation cannot be removed, it will be necessary to remove the blower assembly from the unit for proper wheel cleaning.

Method 2 Blower Assembly removal and replacement

This method is required to replace or repair blower wheel, blower housing, or any unreachable components behind blower assembly.

1. Repeat steps 1 through 4 in method 1.
2. Remove all screws around rim of unit top, (except screws which are inaccessible because of proximity to structure).
3. Raise unit top at corner of unit closest to blower at least 2" and place a sturdy brace at least 2" thick between top and unit corner. See **Figure 25**. A 2X4 piece of wood is ideal for this.
4. Disconnect all wires from housing and slide housing out of unit. Reverse this process to reinstall.

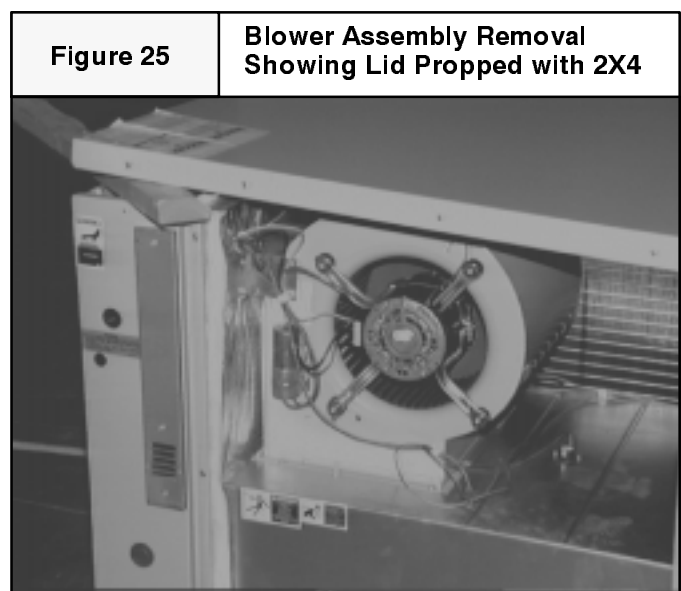

SELECTING BLOWER SPEEDS

The wide variety of applications and installations of furnaces throughout the country makes it impossible to "Factory Select" blower speeds that will provide proper operation for all installations. This means then, that the blower speeds for both heating and cooling must be "Field Selected" for each particular installation to insure proper operation.

The criteria for selecting the proper blower speeds **IS NOT** "High for Cooling, Low for Heating". Although that may be how it works out **SOMETIMES**, It can (in many cases) be exactly the opposite. (I.E. a Lower speed for Cooling, and a Higher speed for Heating)

The PROPER CRITERIA FOR SELECTING BLOWER SPEEDS is as follows:

HEATING

A blower speed must be selected that will provide proper temperature rise through the furnace. (See "checking

temperature rise" found elsewhere in this manual). The required CFM for a particular temperature rise can also be calculated by using the following formula:

$$\frac{\text{Output BTU}}{\text{Temp. Rise X 1.08}} = \text{CFM}$$

EXAMPLE: A model PGAD24D1K equipped with a field installed LOW FIRE KIT (75 Mbtu input) results in an output of 59,000 Btuh. You desire a temperature rise of 60°F (range of 45-75°F allowable) and your **measured** external static pressure is 0.2" W.C. with a dry coil.

$$\frac{59,000}{60 \times 1.08} \text{ or } \frac{59,000}{65} = 908 \text{ CFM}$$

Checking the blower performance data for this model, (see chart below) indicates that @ 0.2" W.C. E.S.P. medium speed will deliver 955 CFM. Accordingly, medium speed should be used in this example for the HEATING speed.

BLOWER PERFORMANCE DATA

Model Number	Motor Speed	Air Delivery in CFM * External Static Pressure (In. W.C.)					
		.20	.30	.40	.50	.60	.70
PGAD18B1K 18C1K	HI	820	785	750	715	670	615
	MD	750	715	685	645	600	550
	LO	615	585	550	515	470	415
PGAD24B1K 24C1K	HI	995	960	925	880	835	780
	MD HI	825	805	775	745	705	660
	MD LO	725	705	675	650	615	570
	LO	620	605	585	565	530	485
PGAD24D1K 30C1K 30D1K	HI	1175	1120	1055	990	920	840
	MD	955	915	870	815	755	685
	LO	790	760	730	690	645	585
PGAD36C1K 36D1K	HI	1435	1375	1310	1245	1175	1105
	MD	1270	1220	1165	1100	1045	990
	LO	1110	1080	1045	1005	955	905

Air delivery against shown external static pressures taken with 230V to unit and dry coil. For wet coil subtract approximately 25 CFM. Add .08 static for internal filters.

* Dry coil, no filter

COOLING

A blower speed must be selected that will provide proper air flow (Nominal 400 CFM per ton) for the air conditioning size (capacity) of the unit at the external static pressure of the Duct system (installation). This requires CHECKING THE EXTERNAL STATIC PRESSURE, and then consulting the BLOWER PERFORMANCE DATA to determine the required speed tap.

400 CFM (nominal) per ton required

400 X 2 = 800 CFM required

EXAMPLE: Using a model PGAD24D1K (the same unit used in the previous example) having an air conditioning capacity of 24,000 BTU (2 ton). The external static pressure is measured and found to be 0.25" W.C. with a wet coil.

Checking the blower performance data (see chart above) for this model indicates that @ 0.2" W.C. ESP low speed will deliver 790 CFM, and @ 0.3" W.C. ESP low speed will deliver 760 CFM. Accordingly, low speed should be used in this example for the COOLING speed.

CHANGING BLOWER SPEEDS

After determining necessary CFM and speed tap data, follow the steps below to change speeds.

1. Refer to **Figure 26** and locate the speed tap block on blower motor.
2. The yellow lead **MUST** always be connected to the speed tap block at the common quick connect terminal. The terminal is identified as **COM**. Also, this is the only lead which is $\frac{3}{16}$ " wide. All other quick connects are $\frac{1}{4}$ " wide.
3. The red lead is connected to the speed tap required for heating, and the black lead is connected to the speed tap required for cooling.
4. If it has been determined that cooling and heating speeds are needed on the same speed tap, remove the red heating lead from the speed tap block and connect it to the insulated male terminal on the black cooling lead. Then place the insulated black female quick connect to the required speed tap.

Figure 26

Blower Motor Speed Taps (3-Speed and 4-Speed Motors)

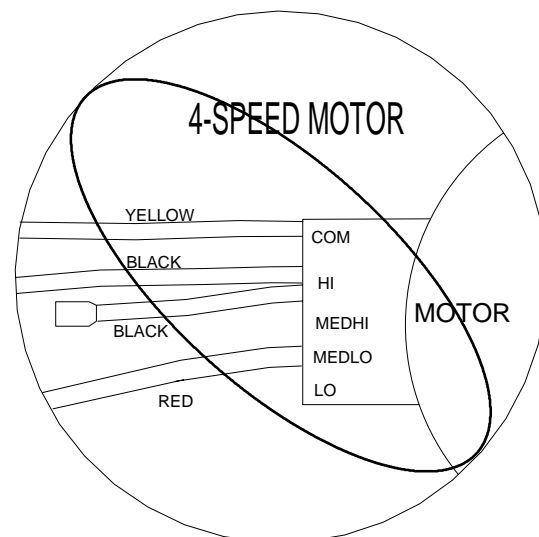
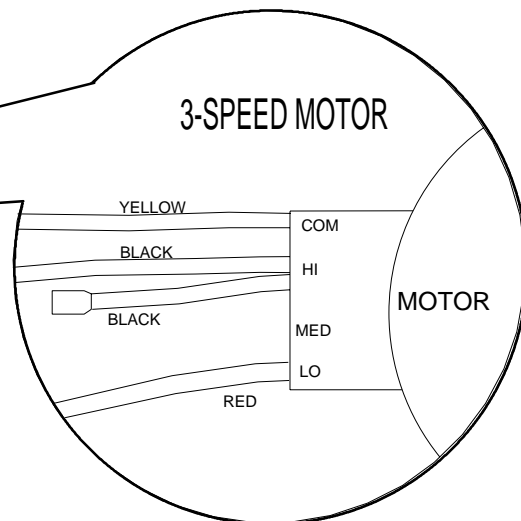
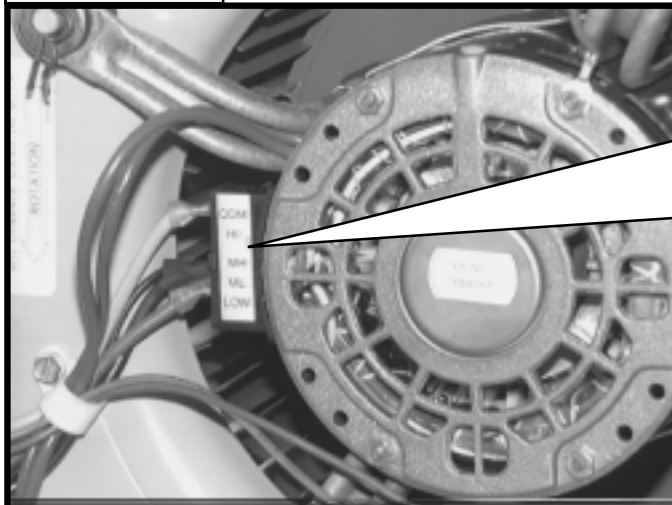

**BE SURE TO CHECK BLOWER MOTOR
SPEED TAP DATA IN UNIT'S
TECHNICAL INFORMATION MANUAL**

BURNER/HEAT EXCHANGER INSPECTION & CLEANING

When required, (or during annual inspection) check the exterior **and** the interior (flue gas passages) of the heat exchanger tubes for any evidence of deterioration due to corrosion, cracking or other causes. If signs of scaling or sooting exist, remove the burners and clean the heat exchanger tubes as required.

Note: Under normal operating circumstances, the heat exchanger should NOT require cleaning. If a Unit requires cleaning, it indicates that there are likely operational problems with the unit, such as low gas pressure, etc. which may cause sooting. The cause of such improper operation **MUST** be determined and corrected to insure continued safe, reliable operation.

INSPECTION AND CLEANING OF BURNER ASSEMBLY AND HEAT EXCHANGER TUBES

Inspecting the burners and heat exchanger tubes requires the use of a light and small mirror on an extension handle.

See **Figure 27**, and **Figure 28** for identification of parts.

1. Disconnect electrical power to unit.
2. Turn gas **OFF** at manual shut off valve.
3. Remove burner access panel.
4. Remove the vent assembly flue cover.

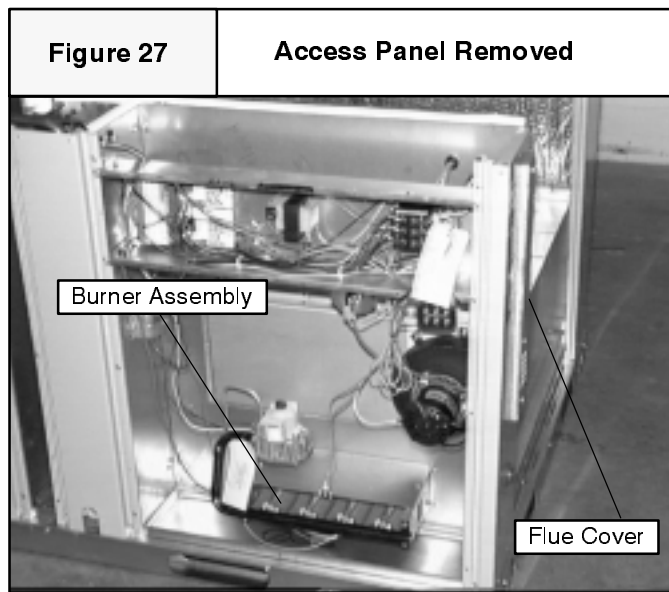

5. Disconnect gas pipe at union.
6. Disconnect wires from gas valve, note connections.

7. Remove screws securing the flame shield and remove gas control valve, manifold and burners as an assembly.
8. Remove collector box, (See Figure 28) injector plate, and restrictor plate, (located behind collector box) being careful not to tear gaskets.
9. Remove burner assembly from bracket and hold the burners vertically and lightly tap it against a wood block. They may also be cleaned with a stiff brush.

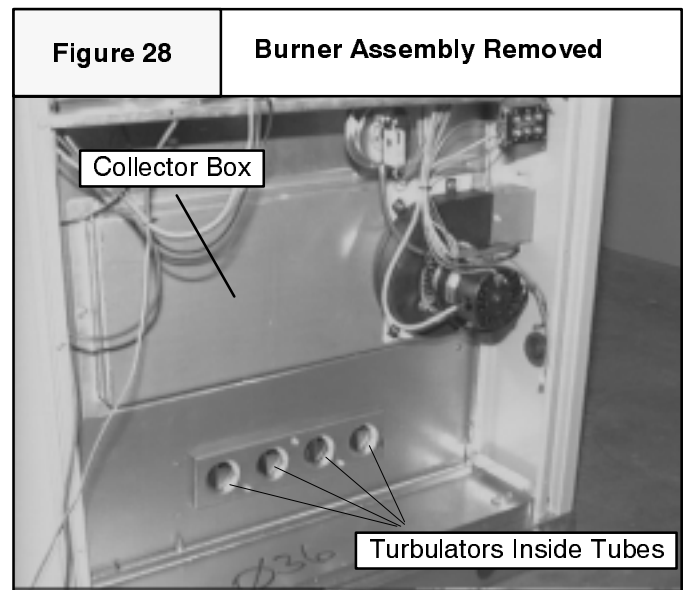

10. Remove turbulators and clean with small brush. Inspect after cleaning for signs of cracking and/or warping and replace turbulators if defective.

NOTE: LP models may not be equipped with turbulators

11. Clean interior of heat exchanger tubes (flue gas passages) by using small brushes and a vacuum cleaner. It may be necessary to fabricate handle extensions for the brushes to reach the areas that require cleaning. Reinspect after cleaning and replace the heat exchanger if defective.
12. Reinstall parts and gaskets in reverse order. Any gaskets damaged during disassembly **MUST** be replaced with new gaskets
13. On spark to pilot models check the spark gap. $\frac{1}{8}$ inch is required between the igniter and pilot hood.
14. Turn gas **ON** and check for leaks. Any leaks found **MUST** be repaired immediately.
15. Install all access panels, turn electrical power on and check furnace section for normal operation.

HEAT EXCHANGER REMOVAL/REPLACEMENT

Removal of the heat exchanger from the unit is only required if the heat exchanger has failed. The cause of heat exchanger failures are normally NOT due to defects in material and workmanship in the heat exchanger itself.

Before replacing any heat exchanger, the cause of its failure MUST (if possible) be determined and corrected. Failure to do so, will cause the replacement heat exchanger to also fail for the same reasons.

Some possible causes of heat exchanger failure are as follows:

1. Temperature Rise too high, (see page 7) causing heat exchanger to exceed design operating temperature. Operating outside allowable temperature rise range will eventually cause cracks to appear in the heat exchanger. Filter may be dirty, registers may be closed off, blower speed may be too low, or unit may be over-fired (manifold pressure too high).
2. Temperature Rise too low, (see page 7) causing heat exchanger to never achieve design operating temperature. Operating outside allowable temperature rise range can allow condensation to form inside the heat exchanger, eventually causing corrosion to appear in the heat exchanger. Blower speed may be too high, return air duct may be open (leaking) to ambient, or unit may be under-fired (manifold pressure too low).

REMOVAL/REPLACEMENT PROCEDURE

1. Turn electrical supply **OFF** to unit at disconnect.
 2. Turn gas supply **OFF** to unit at manual shut off valve
 3. Disconnect gas piping to unit at union.
 4. Remove blower access panel, disconnect wires to blower motor, and limit switch, then remove rear support mounting screws (two on each side) securing heat exchanger to blower deck.
 5. Remove burner access panel, control box cover, and disconnect supply wiring at contactor and control (thermostat) wiring at low voltage terminal board.
 6. Remove screws at front (burner access side) and right (blower access side) edge of top panel. Lift panel slightly, and prop up with 2x4, etc.
 7. Remove screw securing exhaust blower extension to corner post, then remove screws securing corner post to unit, and remove corner post.
 8. Disconnect wires to exhaust blower, rollout switch and disconnect wiring and tubing to pressure switch
 9. Remove remaining screws securing control box to the unit, and carefully lower control box, and allow to hang by wiring.
 10. Compress and remove strain relief bushing securing blower motor and limit switch wires to heat exchanger front division panel.
 11. Carefully move (depending on wire length and/or slack) the control box to the left or top (and out of the way) of the burner access opening. It may also be necessary to remove the compressor run capacitor from its location.
 12. Remove screws around perimeter of heat exchanger front division panel, and remove heat exchanger from unit.
 13. Exhaust blower/collector box assembly and burner/manifold assembly can now be removed from heat exchanger and transferred to replacement heat exchanger. Be sure to use any new gaskets supplied with the replacement heat exchanger.
- NOTE:** If so desired, the exhaust blower/collector box and/or burner/manifold assemblies may be removed prior to removing heat exchanger from unit.
14. Reverse procedure to replace (reinstall) the heat exchanger. Turn gas supply **ON** and check for leaks. Repair any leaks found immediately. Restore electrical power and check furnace section for normal operation.

Figure 29

Burner and Blower Access Panels Removed

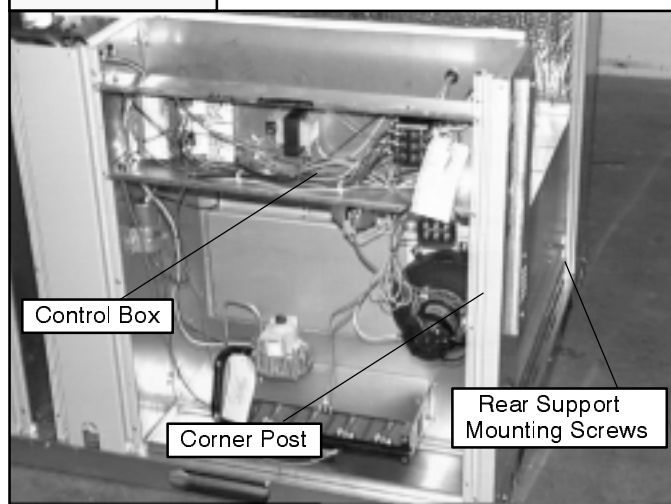

ACCESSORY ECONOMIZERS

Figure 30

Typical Downflow Economizer

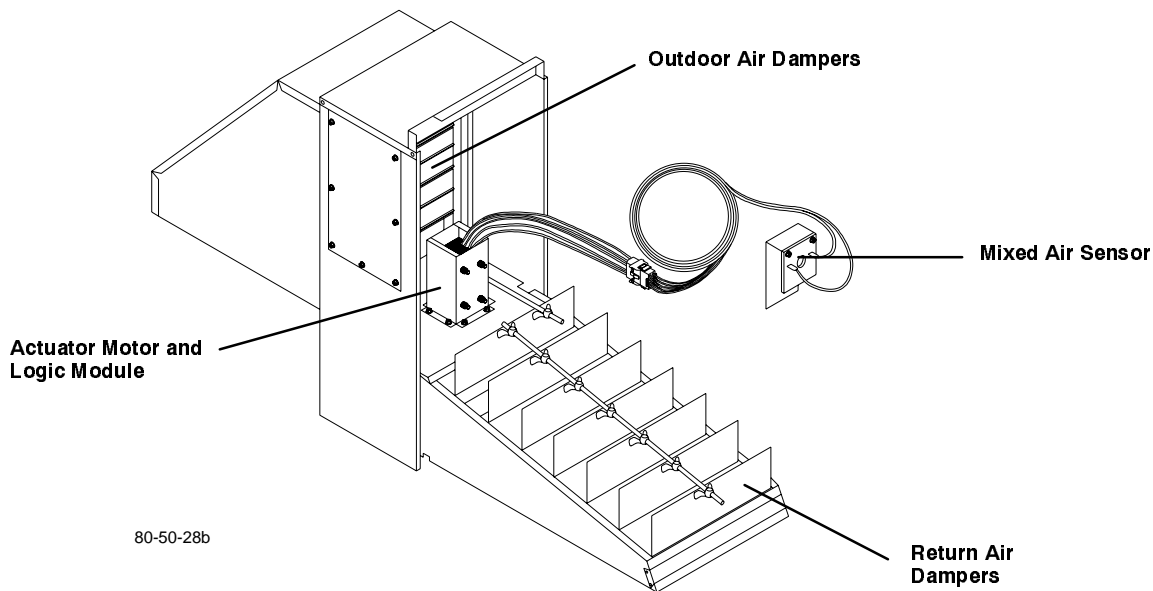

Although an economizer is normally considered a **COMMERCIAL ACCESSORY**, this series of Residential Packaged Gas/Electric unit may (in some cases) be found to be installed with an economizer. Since this Residential series unit shares the same chassis as certain commercial models the same economizers are applicable to it. The economizer can be either a Fully Modulating type or a Three (3) Position type. It will also be of either the Horizontal or Downflow variety depending on the installation configuration. The operation of all economizers is essentially the same.

The purpose of an economizer is to:

- Use outdoor air (when suitable) to cool the conditioned space during the cooling cycle, minimizing the use of compressors.
- Bring outdoor air into the conditioned space to meet minimum ventilation air requirements whenever the circulation blower is running.

Theory of Operation

The economizer is controlled by a logic module which field connects to the unit controls through a harness plug. The logic module also controls the compressor operation based on input it receives from the room thermostat.

Most economizer models have two sets of dampers that are mechanically linked together. The outdoor air dampers

regulate the intake of outdoor air whereas the return air dampers (not included on all models) regulate the flow of return air (see **Figure 30**). When the outdoor air dampers modulate open, the linkage causes the return air dampers (when so equipped) to modulate closed.

The outdoor air dampers open to the minimum position for outdoor air whenever the circulation blower is ON.

The minimum opening position of the outdoor air dampers is field adjustable. It is set on the logic module of modulating economizers or on the actuator motor of three-position economizers.

When the thermostat is in the FAN AUTO position, the outdoor air dampers will close completely whenever heating or cooling is not called for.

A positive pressure may be created in the building when the outdoor air dampers open. This pressure should be vented to insure proper circulation of air in the conditioned space. This requires the use of a barometric relief damper.

A barometric relief damper is installed in the return air side of most economizer models to relieve any positive pressure created by the economizer. A positive pressure will force the passive exhaust dampers to swing open, relieving the pressure.

The enthalpy (temperature & humidity) sensor or outdoor air (temperature only) sensor (depending on model) is

factory installed on the outdoor air dampers. The enthalpy change-over point is adjustable on the logic module.

A mixed air sensor (Mixed air refers to return air after it combines with outdoor air from the economizer.) is field installed in the blower inlet. (See the economizer installation instructions for the proper location of the mixed air sensor. The mixed air sensor keeps the mixed air above 56°F (13.3°C) by controlling the positioning of the outdoor air dampers and return air dampers (when so equipped).

Sequence of Operation

NOTE: For correct wiring to the low voltage terminal board, see the connection wiring diagram in the economizer's documentation.

When using a field supplied **TWO STAGE** thermostat:

1. With the FAN in the "ON" position, the outdoor air dampers will open to the minimum position for outdoor air (open whenever blower is running). If thermostat fan switch is in the AUTO position, outdoor air dampers will open with a call for cooling (see below)
2. On the thermostat's call for cooling, the thermostat completes a circuit between thermostat terminals **R** and **G** and **Y1** for first stage cooling.
3. If (depending upon the model) the economizer's enthalpy (Temperature & Humidity) sensor or outdoor air (Temperature only) sensor determines that the outdoor air conditions are *suitable* to use for cooling, the outdoor air dampers will modulate open and the return air dampers (if so equipped) will modulate closed.
 - a. If outdoor air conditions are *not suitable* to use for cooling, the outdoor air dampers will open to the minimum position, and the return dampers (if so equipped) will fully open. The **Y** circuit of the unit (compressor contactor) will also be energized.
 - b. The compressor will remain energized until the call for cooling ends, or the outdoor conditions change and become suitable to again use for cooling.

4. The mixed air sensor at the blower inlet modulates the economizer dampers to prevent the mixed air from falling below 56°F (13.3°C). (Mixed air refers to return air after it combines with outdoor air from the economizer.) The mixed air sensor modulates the outdoor air dampers between the full open and minimum outdoor air positions.
5. If the mixed air is not cold enough to maintain the conditioned space at the selected temperature, the room thermostat will make **Y2** and call for second stage cooling by energizing the economizer logic module. This in turn energizes the **Y** circuit of the unit to energize its contactor which starts the condenser fan and the compressor.

NOTE: Some units have a low voltage safety circuit (in series with the compressor contactor) which may include a freeze thermostat, high pressure switch, low pressure switch, and/or an anti-cycle timer.

6. If conditions should change and the economizer's enthalpy (temperature & humidity) sensor or outdoor air (temperature only) sensor determine that the outdoor air is *no longer (not) suitable* for cooling, and the thermostat is still calling for cooling :
 - a. The economizer dampers will return to the minimum position for outdoor air and remain there.
 - b. The contactor will remain energized and the compressor will continue to run.

When using a field supplied **SINGLE STAGE** thermostat:

All of the steps outlined above (when using a **TWO STAGE** thermostat) will still apply, with the following exceptions:

- a. When outdoor air conditions are *suitable* to use for cooling, the outdoor air dampers will open to the minimum position, the return air dampers (if so equipped) will close, and the compressor will remain OFF until conditions change, or the thermostat is satisfied.
- b. When outdoor air conditions are *not suitable* to use for cooling, the outdoor air dampers will remain at their minimum position, the return air dampers (if so equipped) will open, and the **Y** circuit of the unit (compressor contactor) will be energized.

COMPRESSORS

Two (2) different types of compressors are used in this series of Residential Packaged Gas/Electric unit. The first type is the "Standard" reciprocating type compressor, which has been in use in the industry for many years. The second type of compressor that is used in this series is the SCROLL compressor. The Scroll compressor may easily be distinguished from a reciprocating compressor by its relatively tall, and relatively small diameter round case.

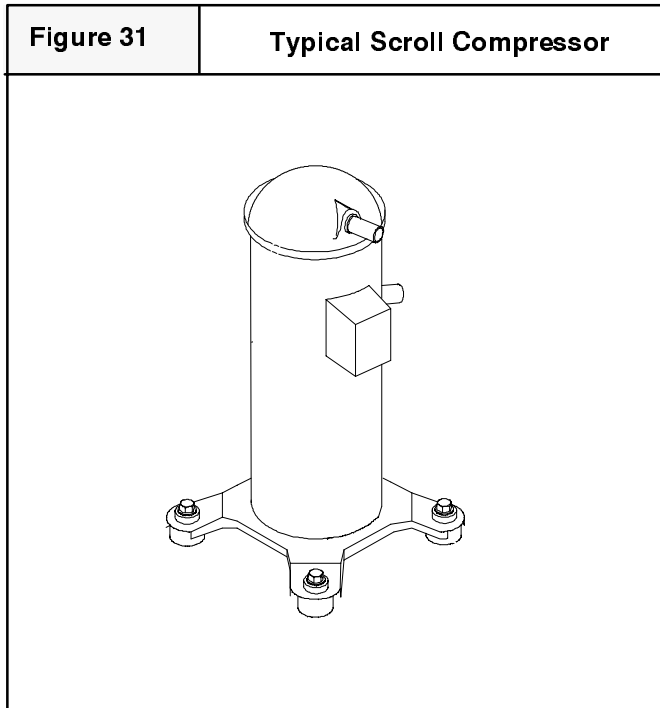

Although the methods of testing and/or check-out of both types of compressors is essentially the same, the Scroll compressor differs from the reciprocating type compressor in several ways.

First, the Scroll compressor uses a pair of Scrolls (one stationary, one "orbiting") to compress and pump refrigerant through the system, instead of the piston and valve arrangement found in a reciprocating compressor. This design makes the Scroll compressor able to tolerate a certain amount of liquid refrigerant better than a reciprocating compressor. Consequently, crankcase heaters are not normally required on most scroll equipped models.

Operating Noise Level

The operating noise characteristics of a scroll compressor also differ considerably from that of a reciprocating compressor. If you are unfamiliar with the operating noise characteristics of a scroll compressor, you should be absolutely certain that there is a problem

with the compressor prior to replacing it. For example, a scroll compressor which is running in reverse rotation (see anti-cycle timer section on page 30) will apparently make an excessive amount of noise.

COMPRESSOR CONTACTOR

The compressor contactor is a "Normally Open" single throw switch (Relay) which when energized closes to complete the line voltage circuit to the compressor. Depending upon the model, either a SINGLE POLE contactor or a DOUBLE POLE contactor may be used.

WARNING

Electrical shock hazard.

Single Pole Contactors break ONLY one (1) side of the line voltage circuit within the unit.

Disconnect power at fuse box or service panel before performing any service on the unit.

Failure to follow this warning can result in property damage, personal injury, and/or death.

The contactor coil is energized on a call for COOLING from the room thermostat. If the contactor is not being energized (Pulled-In) it may be checked as follows:

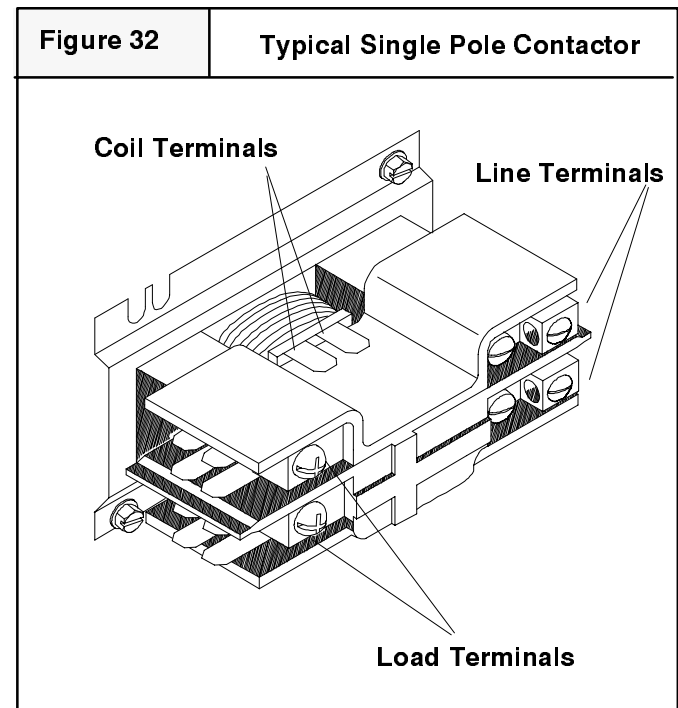

A check across the two (2) coil terminals of the contactor should indicate 24 Volts during a call for cooling. If 24

volts IS indicated, and the contactor does not Pull-In, the contactor is faulty (either a bad coil or mechanically stuck).

If 24 volts is NOT indicated in the above test, check across "Y" and "C" of the unit's low voltage terminal board during a call for COOLING. This should also indicate 24 Volts. If not, there may be problems with the thermostat, control wiring, or low voltage transformer.

Problems with the transformer can quickly be ruled out by Jumpering between "R" & "G" on the low voltage terminal strip in the unit (or switching the FAN switch on the thermostat sub-base from AUTO to "ON"). If the Blower starts and runs, the transformer is O.K.

Once the transformer has been determined to be good, a jumper placed between "R" & "Y" on the unit's low voltage terminal strip should cause the contactor coil to be energized. If so, The problem is in the Thermostat OR Thermostat wiring. If not, the problem is in the wiring between the terminal strip and the contactor. Check .

CRANKCASE HEATER

Some models are equipped with a crankcase heater. The purpose of a crankcase heater is to keep liquid refrigerant from settling in the compressor crankcase during "OFF" cycles in mild weather.

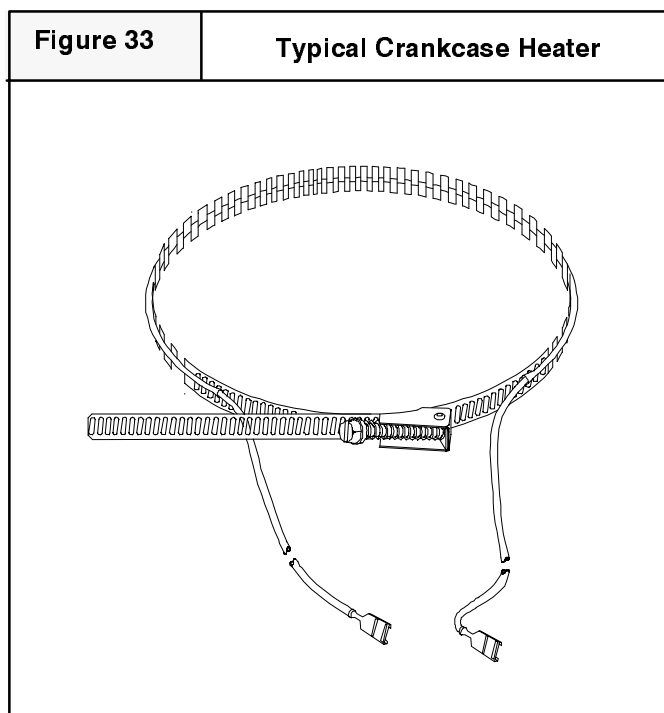

On models equipped with a reciprocating compressor this heater is normally a wrap around ("Belly-Band") type resistance heater. Depending on the model, this type of heater may or may not be also equipped with a crankcase heater thermostat (see Figure 34). A simple

resistance (Ohms) check across the two leads of this heater will indicate its condition.

As stated previously, scroll compressor models normally will not be equipped with a crankcase heater. If, however a crankcase heater is in fact used it may be either a wrap around or a stick-on type. The latter of which is a solid state (PTCR) type heater. The PTCR (Positive Temperature Coefficient Resistor) type heater may also be checked using a resistance check, however the indications will have a different meaning. A PTCR type heater is essentially a Thermistor (a Resistor whose value changes relative to temperature). This type of heater will indicate a LOW resistance reading (approx. 10-100 Ohms) when cool, and a HIGH resistance reading (Near Infinity) when warm. Consequently, this type of heater MUST be checked when cool (de-energized 10-15 minutes). Since this type of heater is self-regulating, a crankcase heater thermostat is not required or used.

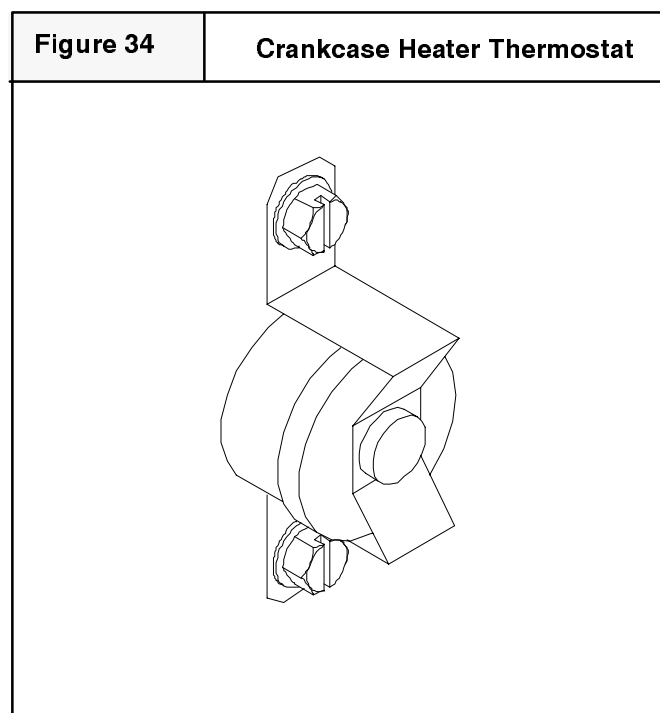

CRANKCASE HEATER THERMOSTAT

Some models use a crankcase heater thermostat (mounted in the unit's control box) to control the circuit to the crankcase heater. This control is a Single Pole Single Throw (SPST) switch in series with the crankcase heater. The switch closes at $65^{\circ}\text{F} \pm 6^{\circ}\text{F}$ which insures that the heater will be energized when the outdoor ambient temperature is below this range. The switch will open at $75^{\circ}\text{F} \pm 5^{\circ}\text{F}$ which insures that the heater will be de-energized when the outdoor ambient temperature is above this range. Since a crankcase heater is only necessary in cooler ambient temperatures, the heater is only energized when necessary thereby saving the electricity it would normally consume.

COMPRESSOR CONTROL CIRCUIT

The compressor control circuit of most models will contain at least one of the controls listed in the sections that follow below. Whenever servicing a unit whose contactor will not Pull-in (energize), these controls should be suspect since they are wired in series with the compressor contactor coil.

ANTI-CYCLE TIMER (SCROLL COMPRESSOR MODELS)

Single phase scroll compressor models are equipped with an electronic Anti-Cycle timer. This timer is required to prevent the possibility of the compressor running in reverse rotation due to a momentary power interruption.

The anti-cycle timer is essentially a "delay on break" timer which prevents the compressor contactor from re-energizing for a period of 30 seconds if the power to it is interrupted for as little as 16 milliseconds. This delay provides sufficient time for the compressor to come to a complete stop before being re-energized, preventing the compressor from starting in reverse rotation. If defective, however, it will not complete the circuit to the contactor.

The Anti-Cycle timer may be checked by using a Voltmeter. With the power "ON" and Thermostat calling for cooling (for at least 30 seconds). 24 Volts should be indicated across terminals #1 & #2 and #3 & #2. Zero (0) volts should be indicated across terminals #1 & #3 (indicating a closed circuit) Any other readings obtained are indicative of problems within the timer.

Figure 35

Typical Anti-Cycle Timer

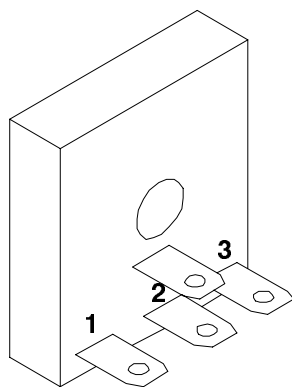

DISCHARGE THERMOSTAT (SCROLL COMPRESSOR MODELS)

Scroll compressor models may also be equipped with a discharge thermostat (also referred to as a Dome Thermostat, Top Cap Thermostat or a Compressor Protector). Its purpose is to protect the compressor from damage caused by high discharge temperature. High discharge temperature may be caused by items such as insufficient refrigerant charge, restriction in the refrigerant circuit, etc.

Figure 36

Scroll Dome Thermostat Location

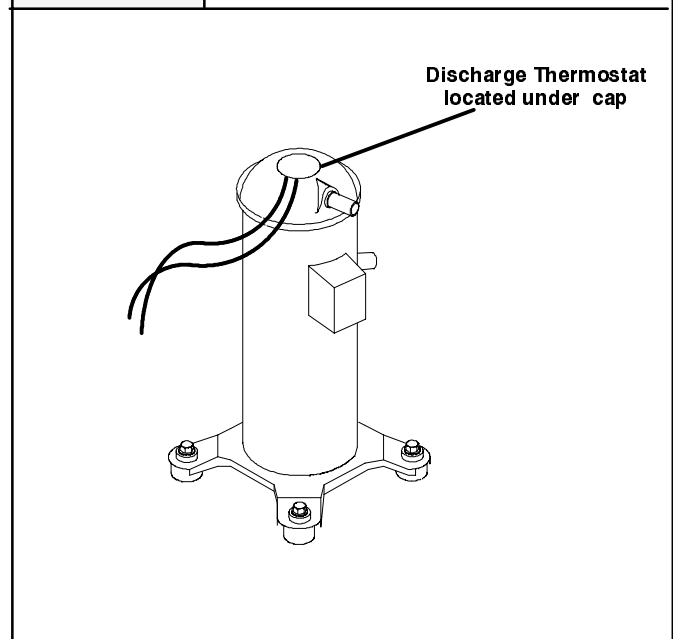

The discharge thermostat is a "Normally Closed" temperature operated switch (Automatic Reset) wired in series with the compressor contactor. The switch will remain closed until the discharge temperature (as sensed in the top of the dome of the compressor) rises above $280^{\circ}\text{F} \pm 40^{\circ}\text{F}$. At this point the switch will open breaking the circuit to the contactor. Once open, the switch will remain open until the dome temperature drops to $100^{\circ}\text{F} \pm 15^{\circ}\text{F}$, at which time it will close and once again complete the circuit to the contactor.

LOW PRESSURE SWITCH

Some units may be equipped with an optional low pressure switch (loss of charge protector) connected to a fitting on the unit's LIQUID LINE. The purpose of this switch is to prevent damage to the compressor caused by operating with insufficient refrigerant charge. Operating the unit with insufficient refrigerant charge can cause a variety of problems within the unit. Among these

are Overheating of compressor windings, and freezing of the evaporator coil.

The low pressure switch (loss of charge protector) is a "Normally Open" pressure operated switch (Automatic Reset) wired in series with the compressor contactor. The switch closes at 50 ± 6 psig of pressure in the refrigeration system completing the circuit to the compressor contactor. The switch will remain closed until the system pressure drops below 20 ± 7 psig, at which time it will open, breaking the circuit to the compressor contactor.

HIGH PRESSURE SWITCH

Some units may be equipped with an optional high pressure switch. The purpose of the high pressure switch is to prevent damage to the compressor which may occur as a result of operating under high discharge pressure conditions. Some possible causes of high discharge include condenser fan motor failure, excessive refrigerant charge, air and non-condensibles in refrigerant circuit, etc.

The high pressure switch is a "Normally Closed" pressure operated switch (Automatic Reset) wired in series with the compressor contactor. The switch will remain closed, completing the circuit to the compressor contactor until the discharge pressure rises above 420 ± 15 psig. At this point the switch will open, breaking the circuit to the compressor contactor. The switch then will remain open until the pressure drops to 300 ± 20 psig, at which time it

will close again, completing the circuit to the compressor contactor.

FREEZE THERMOSTAT

Some units may be equipped with an optional freeze thermostat. The purpose of the freeze thermostat is to prevent damage to the compressor which may be caused by the evaporator coil freezing. Some possible causes of the evaporator freezing are blower motor failure, plugged filter, low ambient operation without proper protection (see low ambient control above), etc.

The control is a "Normally Closed" temperature operated switch (attached to one of the return bends of the evaporator coil) wired in series with the compressor contactor. When the evaporator temperature drops below $30^{\circ}\text{F} \pm 5^{\circ}\text{F}$ the switch will open, breaking the circuit to the compressor. This will allow the evaporator coil temperature to rise due to lack of refrigerant flow through the coil.

The increased evaporator temperature permits the evaporator to defrost. Then, when the evaporator temperature rises above $50^{\circ}\text{F} \pm 6^{\circ}\text{F}$ (consequently, it should now be defrosted) the switch will close, completing the circuit to the compressor contactor.

The component part used for the freeze thermostat may be identical to that used for the low ambient control described on page 33. Or, it may have different wire colors and/or lengths. It can be used interchangeably as long as it is properly attached, and wired into the circuit.

COMPRESSOR CHECKS

LOCKED ROTOR VOLTAGE CHECK

One of the most important, often overlooked, and/or misunderstood compressor checks is a locked rotor VOLTAGE check. Locked rotor voltage can be defined as the voltage available to start the compressor under Locked Rotor (initial start or stalled) Conditions. Or, in other words, the voltage available to the compressor while it is (for example) humming and ATTEMPTING to start but failing to do so.

Locked rotor voltage is checked using a standard Voltmeter with the power to the unit ON, while the compressor is attempting to start. If your voltmeter is equipped with alligator clips, this may be checked at the compressor by connecting your voltmeter (making sure power is OFF while connecting) as shown in Figure 37. If your voltmeter IS NOT equipped with alligator clips, this check should be made at the "T1" & "T2" terminals of the compressor contactor.

When checking a unit whose compressor will not start at all, turn power back on and stand back (away) from the compressor terminals during the test. Call for cooling, and while compressor is humming and attempting to start check voltage reading.

When checking a unit whose compressor starts, the procedure differs slightly. Turn power back on and stand back (away) from the compressor terminals during the test. Call for cooling, and once the compressor starts, turn the power OFF and IMMEDIATELY back ON. This should cause the compressor to stall (locked rotor) and begin humming. During this time, check voltage reading.

Note: On models equipped with Scroll compressors it may not be possible to stall the compressor using the above procedure.

Under locked rotor conditions, the voltage available across the "C" (common) and "R" (run) terminals of the compressor (or "T1" & "T2" terminals of the contactor) must be at least 197 Volts.

Figure 37

Checking Locked Rotor Voltage

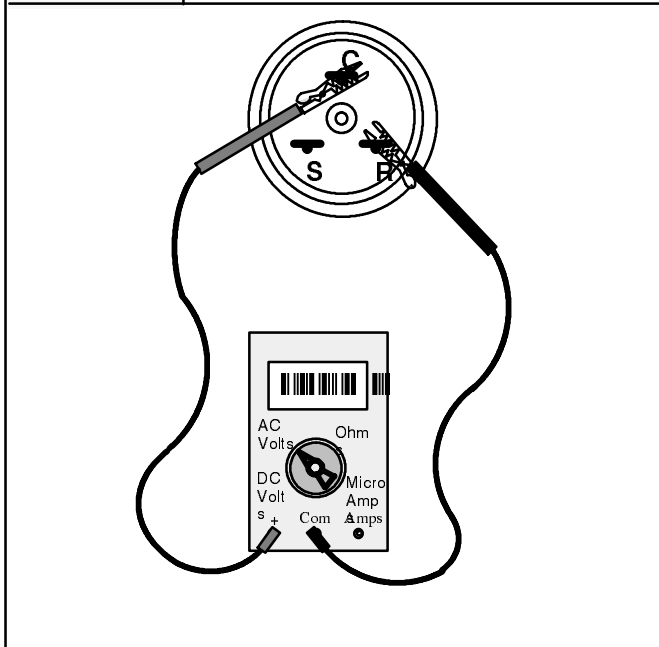

Locked Rotor Voltage readings of less than 197 volts will not allow the compressor to start. If your reading is less than 197 volts, problems may be indicated in the unit's electrical supply circuit. Some examples of these problems are undersized supply wiring, excessive length of supply run, and loose and/or dirty (high resistance) connections in the supply circuit. These conditions MUST be corrected before the compressor can be expected to start reliably.

The compressor contactor itself can also be a cause of low locked rotor voltage readings. To check and rule out this possibility, check the locked rotor voltage across the "L1" & "L2" terminals of the compressor contactor. If the voltage reading is the same as that obtained across the "T1" & "T2" terminals, then supply circuit problems are indicated. If, however, the locked rotor voltage across "L1" & "L2" is Higher than it is across "T1" & "T2", there is high resistance through the points of the compressor contactor causing the voltage drop, and the contactor should be replaced.

COMPRESSOR WINDING CHECKS

If the compressor fails to start, the compressor windings should be checked for open circuits and/or short circuits in order to determine their condition. Winding checks are made using a standard Ohmmeter (See Figure 38), with the power to the unit OFF.

WARNING

Electrical shock hazard.

Disconnect power at fuse box or service panel before checking compressor windings.

Failure to follow this warning can result in property damage, personal injury, and/or death.

Checking for open windings

With power to the unit OFF, disconnect wiring to the compressor. Resistance should be checked between terminals C & R, C & S, and S & R. The reading between C & R should indicate the LEAST resistance. The reading between C & S should indicate a HIGHER resistance (than between C & R). The Reading between S & R should indicate the TOTAL of the readings obtained between C & R and C & S. This check will indicate if any of the windings are open. A reading of infinity (∞) between any two terminals MAY indicate an open winding. If, however, a reading of infinity (∞) is obtained between C & R and C & S, accompanied by a resistance reading between S & R, an open internal overload is indicated. Should obtain this indication, allow the compressor to cool (may take up to 24 hours) then re-check before condemning the compressor.

Figure 38

Checking Compressor Windings

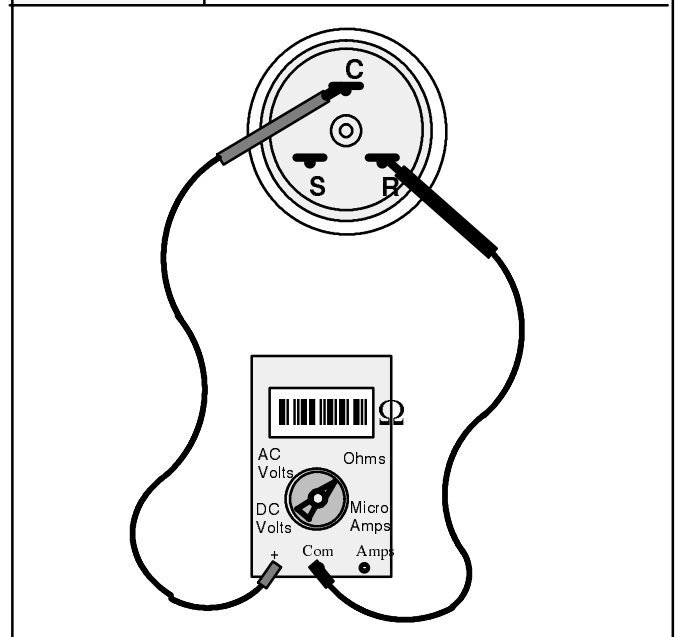

If an open internal overload is indicated, the source of its opening must be determined and corrected. Failure to do so will cause repeat problems with an open overload

and/or premature compressor failure. Some possible causes of an open internal overload include insufficient refrigerant charge, restriction in the refrigerant circuit, and excessive current draw.

Checking for shorted (grounded) windings

The Compressor should also be checked for shorted (grounded to case) windings anytime the fuse or circuit breaker to the unit is tripping. You should also check the compressor for shorted windings whenever there is a starting problem, since there may be enough resistance in the shorted winding to prevent the fuse or circuit breaker from tripping.

With power to the unit OFF, disconnect wiring to the compressor. Resistance should be checked (one terminal at a time) between terminals C, S, R, and the compressor case (the suction line may be used for this purpose). Be certain to insure that (when using the compressor case) the point of contact of the Ohmmeter probe is clean and free from paint. The reading between each terminal (C, S, & R) and the compressor case should indicate infinity (∞). Any reading obtained less

than infinity (∞) is indicative of a shorted (grounded) winding, and the compressor should be replaced.

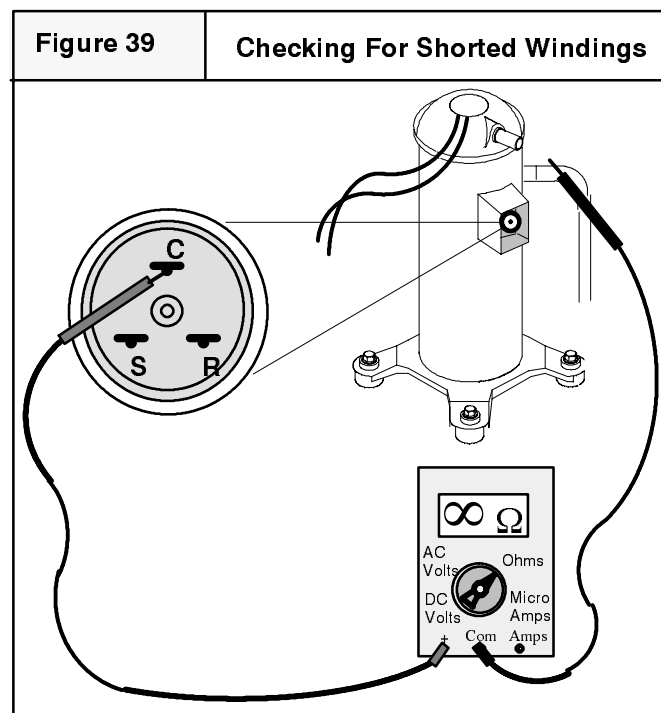

CONDENSER FAN CONTROL CIRCUIT

The condenser fan motor is controlled by the compressor contactor. Anytime the compressor is operating, the condenser fan motor should also be operating. When servicing a unit whose condenser fan motor will not run, both its capacitor (may be a dual capacitor shared with compressor) and low ambient control (if so equipped) should be suspect since they are part of the circuit.

LOW AMBIENT CONTROL

Some units may be equipped with an optional low ambient control. The purpose of this control is to cycle the condenser fan motor "OFF" and "ON" to maintain head (discharge) pressure in the refrigeration system during low ambient (Outdoor Temperature) operation.

The control is a "Normally Closed" temperature operated switch (attached to one of the return bends of the evaporator coil) wired in series with the condenser fan motor. When the evaporator temperature drops below $30^{\circ}\text{F} \pm 5^{\circ}\text{F}$ the switch will open, breaking the circuit to the condenser fan motor. This will cause the discharge pressure to rise (due to lack of airflow across the condenser coil), which in turn will increase the suction pressure.

The increased suction pressure causes the evaporator temperature to rise. Then, when the evaporator temperature rises above $50^{\circ}\text{F} \pm 6^{\circ}\text{F}$ the switch will close, completing the circuit to the condenser fan motor.

The component part used for the low ambient control may be identical to the part used for the freeze thermostat described on page 31. Or, it may have different wire colors and/or lengths. It can be used interchangeably, however, as long as it is properly attached, and wired into the circuit.

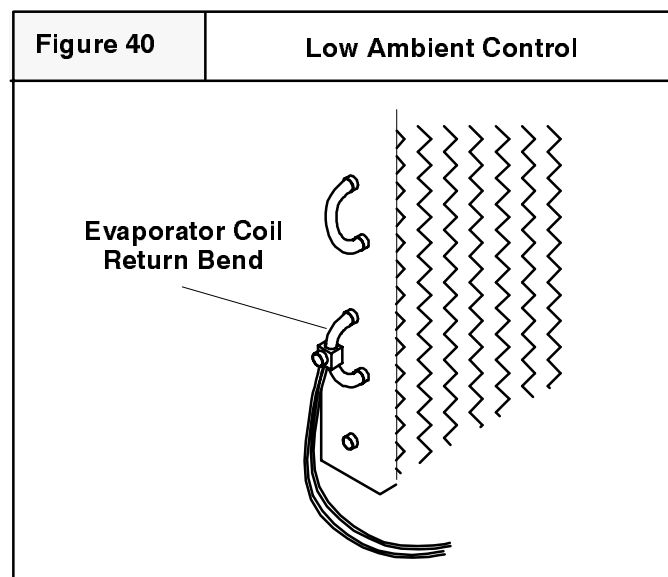

REFRIGERANT CHARGING

Proper refrigerant charge is essential to proper unit operation. It is also essential to obtaining the published efficiency from as well as the expected life span of the compressor contained within the unit. Operating a unit with an improper refrigerant charge will result in reduced performance (capacity) and/or efficiency. Accordingly, the use of proper charging methods during servicing will insure that the unit is functioning as designed and that its compressor will not be damaged.

Too much refrigerant (Overcharge) in the system is just as bad (if not worse) than not enough refrigerant (Undercharge). They both can be the source of certain compressor failures if they remain uncorrected for any period of time. Quite often, other problems (such as low air flow across evaporator, etc.) are mis-diagnosed as refrigerant charge problems. The refrigerant circuit diagnosis chart on page 143 will assist you in properly diagnosing these symptoms.

For example an overcharged unit will at times return liquid refrigerant (slugging) back to the suction side of the compressor eventually causing a mechanical failure within the compressor. This mechanical failure can manifest itself as valve failure, bearing failure, and/or connecting rod failure. The specific type of failure will be influenced by the amount of liquid being returned, the length of time the slugging continues, and the type of compressor (scroll or reciprocating) being used in the unit.

Not enough refrigerant (undercharge) on the other hand, will cause the temperature of the suction gas to increase to the point where it does not provide sufficient cooling for the compressor motor. When this occurs, the motor winding temperature will increase, causing the motor to overheat and possibly cycle (open) the internal overload protector. Continued overheating of the motor windings and/or cycling of the internal overload will eventually lead to compressor motor or internal overload failure.

METHODS OF CHARGING

There are three (3) recognized and acceptable methods for charging this series of packaged gas/electric unit. Two (2) of which will be applicable to the unit you are servicing. The three (3) methods are :

1. Weighed in Charge Method
2. Superheat Method
3. Subcooling Method

The weighed in charge method is applicable to ALL units. It is the preferred method to use, as it is the most accurate. The Superheat method is applicable to units with CAPILLARY TUBE controlled evaporators ONLY. The Subcooling method is applicable to units equipped with Thermostatic Expansion Valve controlled evaporators. The particular method(s) that you use will depend on the unit you are servicing, the type of equipment you have, and your personal preference. The sections that follow describe the methods their required procedures in more detail.

Weighed in Charge Method

The weighed in charge method is applicable to ALL units, and is the preferred method to use because of its accuracy. Charging by this method is accomplished with the unit OFF and requires the use of a graduated charging cylinder, or electronic scales.

This method should always be used (if possible) whenever the charge is to be removed from the unit, such as for a leak repair, compressor replacement, or when there is no refrigerant charge left in the unit. To charge by this method, requires the following steps:

1. Recover refrigerant (remaining) charge from unit in accordance with EPA regulations.
2. Make system (leak, etc.) repairs as necessary.
3. Evacuate system to 500 microns.
4. Charge unit (through high side access port) with quantity of refrigerant listed on unit's rating plate, and/or Tech. Service Data Sheet.
5. Start unit, and verify performance.

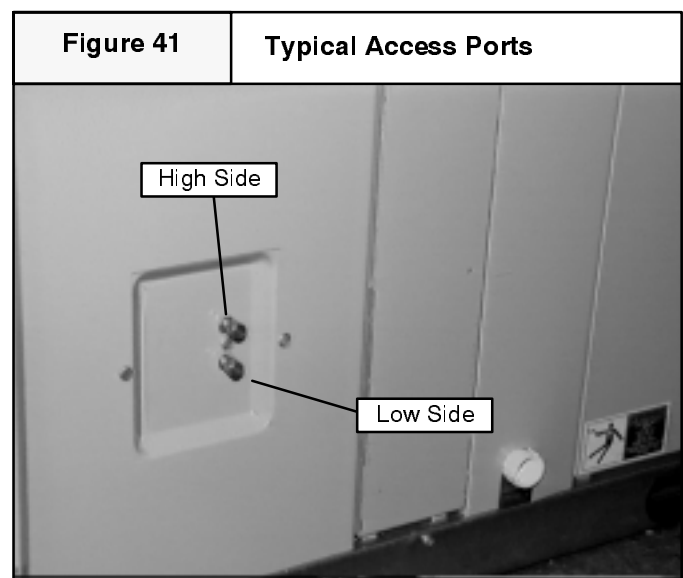

Superheat Method

The Superheat method is applicable to units equipped with CAPILLARY TUBE controlled evaporators ONLY. Charging by the Superheat method is accomplished with the unit RUNNING and requires the use of ACCURATE refrigeration gauges, Wet Bulb and Dry bulb thermometers, and a Pressure/Temperature chart (if your refrigeration gauges do not have temperature conversion scales on their face).

The Superheat method can be used when a partial charge remains in the unit and it is not desirable to remove the entire charge. To charge by the Superheat method the requires the following steps:

1. Connect refrigerant gauges to service access ports, start unit and allow to run for several minutes until system pressures stabilize.
2. While waiting for pressures to stabilize, measure and record Outdoor Dry Bulb temperature, Indoor Wet Bulb temperature, and Indoor Dry Bulb temperature.
3. Measure (and record) suction line temperature as close to compressor as practical.
4. Using R-22 temperature conversion scale on gauges (if so equipped) or pressure/temperature chart (see Figure 42) convert suction pressure to (saturation) temperature.
5. Subtract converted (saturation) temperature from measured suction temperature; the result is Superheat.
6. Compare calculated Superheat with allowable range of Superheat (for existing conditions) indicated on chart in Figure 42
7. If calculated Superheat is HIGHER than allowable range, gradually ADD refrigerant (vapor) through suction side of system. Recheck Superheat periodically (while adding refrigerant), and discontinue adding refrigerant when allowable range has been reached.
8. If calculated Superheat is LOWER than allowable range, gradually remove (recover) refrigerant from system. Recheck Superheat periodically while removing (recovering) refrigerant, and discontinue removing refrigerant when allowable range has been reached.

Subcooling Method

The Subcooling method is applicable to units equipped with THERMOSTATIC EXPANSION VALVE controlled evaporators. Charging by the subcooling method is accomplished with the unit RUNNING. It requires the use of ACCURATE refrigeration gauges, Dry bulb thermometer, and a Pressure/Temperature chart (if your refrigeration gauges do not have temperature conversion scales on their face).

The Subcooling method can be used when a partial charge remains in the unit and it is not desirable to remove the entire charge. To charge by the Subcooling method the requires the following steps:

1. Connect refrigerant gauges to service access ports, start unit and allow to run for several minutes until system pressures stabilize.
2. While waiting for pressures to stabilize, measure Outdoor Dry Bulb temperature, (must be between 65°F and 115°F).
3. Measure (and record) liquid line temperature as close to condenser coil OUTLET as practical.
4. Using R-22 temperature conversion scale on High Side gauge (if so equipped) or pressure/temperature chart, (see Figure 42) convert liquid pressure to (saturation) temperature.
5. Subtract measured liquid temperature from converted (saturation) temperature; the result is Subcooling.
6. Compare calculated Subcooling with allowable range (8°F - 12°F) of subcooling .
7. If calculated Subcooling is HIGHER than allowable range, gradually REMOVE (recover) refrigerant (vapor) from suction side of system. Recheck Subcooling periodically (while removing refrigerant), and discontinue removing refrigerant when allowable range has been reached.
8. If calculated Subcooling is LOWER than allowable range, gradually ADD refrigerant (vapor) to the suction side of system. Recheck Subcooling periodically while adding refrigerant, and discontinue adding refrigerant when allowable range has been reached.

Figure 42

System Charging Procedures

The **preferred method** of charging is to weigh the charge in using the quantity of refrigerant listed on the unit's rating plate and/or Tech. Data Sheet. When this is not practical, the Superheat and Subcooling methods described below (as applicable) are acceptable alternatives.

SUPERHEAT METHOD - Systems with Capillary Tube controlled Evaporator Coil ONLY

1. Measure and record Indoor wet bulb and dry bulb temperatures and Outdoor dry bulb temperature.
2. Measure suction line temperature within 6 inches of the compressor.
3. Measure suction line pressure at service access port and determine saturated suction temperature from chart.
4. Subtract saturated suction temperature from measured suction line temperature to obtain superheat.
5. Compare with allowable Superheat range (for current conditions) and adjust charge as required.

SATURATED TEMPERATURE - PRESSURE CHART					
(°F)	R22-PSIG	(°F)	R22-PSIG	(°F)	R22-PSIG
32	57.5	44	74.5	80	143.6
33	58.8	45	76.0	85	155.7
34	60.1	46	77.6	90	168.4
35	61.5	47	79.2	95	181.8
36	62.8	48	80.8	100	195.8
37	64.2	49	82.4	105	210.8
38	65.6	50	84.0	110	226.4
39	67.1	55	92.6	115	242.7
40	68.5	60	101.6	120	259.9
41	70.0	65	111.2	125	277.9
42	71.4	70	121.4	130	296.8
43	73.0	75	132.2	140	337.3

SUPERHEAT MEASURED AT SUCTION LINE			
Outdoor Temp. (°F)	Indoor Conditions DB/WB (50%R.H.)		
	75 / 63	80 / 67	85 / 71
105	2-6	2-6	10-12
100	2-6	5-7	12-14
95	2-6	8-10	14-17
90	4-6	11-13	16-19
85	7-10	14-16	19-22
80	10-13	16-19	22-25
75	13-16	19-22	24-27
70	17-20	22-25	27-30
65	20-23	25-28	29-33
60	23-27	27-31	32-36
55	26-30	29-34	34-38

SUBCOOLING METHOD - Systems with Expansion Valve controlled Evaporator Coil

1. Measure outdoor ambient, must be between 65 °F and 115 °F.
2. Measure liquid line temperature 6 inches from outlet of condenser coil.
3. Measure liquid line pressure at service access port and determine saturated liquid temperature from chart.
4. Subtract measured liquid line temperature from saturated liquid temperature to obtain subcooling.
5. Adjust charge as required to obtain 8 °F - 12 °F subcooling.

NOTE: Optimum performance for units equipped with **capillary tubes** is obtained with 8°F superheat at compressor inlet under DOE "A" test conditions (95°F Outdoor Dry Bulb temperature, 80°F Indoor Dry Bulb Temperature, and 67°F Indoor Wet Bulb Temperature).

Dryer Sizes:

Tons	Cu In	Oz	Suct Sq In
1 -1 ¹ / ₂	5	5	17
2 -2 ¹ / ₂	8	7	30
3 -3 ¹ / ₂	16	11	30
4-5	30	17	30

TECHNICAL SERVICE DATA INDEX

MODEL NUMBER	TECH. SHEET	PAGE	MODEL NUMBER	TECH. SHEET	PAGE
G4P			PGAA24C1K3	1067911	64
G4P018A3A1	1065408-A	42	PGAA24D1K1	1065412-B	44
G4P018A3B1	1065409-A	42	PGAA24D1K3	1067912	64
G4P024A3A1	1065410	43	PGAA29C1K1	1065307-A	41
G4P024A3B1	1065411	43	PGAA29D1K1	1065471-A	48
G4P030A3B1	1065413-B	44	PGAA30C1K1	1065413-B	44
G4P030A3C1	1065414-A	45	PGAA30C1K3	1067913	65
G4P036A3C2	1066309	55	PGAA30D1K1	1065414-A	45
G4P036A3D2	1066310	56	PGAA30D1K3	1067914	65
G4P042A3B1	1065418-B	47	PGAA36C1K1	1065415-B	45
G4P042A3D1	1065419-B	47	PGAA36C1K2	1066308	55
G4P047A3C1	1054587	40	PGAA36C1K3	1067927	68
G4P047A3E1	1066431	56	PGAA36D1K1	1065416-B	46
G4P060A3D1	1065559-A	49	PGAA36D1K2	1066309	55
G4P060A3F1	1065567-A	50	PGAA36D1K3	1067928	69
G6P			PGAA36E1K1	1065417-B	46
G6P024A3A1	1065848-A	51	PGAA36E1K2	1066310	56
G6P024A3B1	1065849-A	51	PGAA36E1K4	1067929	69
G6P024A3C1	1065850-A	52	PGAA42C1K1	1065418-B	47
G6P030A3B1	1065113	40	PGAA42C1K3	1067935	70
G6P030A3C1	1065170	41	PGAA42E1K1	1065419-B	47
G6P036A3B1	1065956	52	PGAA42E1K3	1067936	70
G6P036A3C1	1065957	53	PGAA47D1K1	1054587	40
G6P036A3D1	1065958	53	PGAA47D1K3	1067984	74
PGAA			PGAA47F1K1	1066431	56
PGAA18B1K1	1065408-A	42	PGAA47F1K3	1067985	74
PGAA18B1K3	1067908	62	PGAA48D1K1	1065543-A	48
PGAA18C1K1	1065409-A	42	PGAA48D2K1	1065543-A	48
PGAA18C1K3	1067909	63	PGAA48F1K1	1065551-A	49
PGAA24B1K1	1065410	43	PGAA48F2K1	1065551-A	49
PGAA24B1K3	1067910	63	PGAA60D1K1	1065559-A	49
PGAA24C1K1	1065411	43	PGAA60D1K3	1067986	75
			PGAA60D2K1	1065559-A	49
			PGAA60E1K1	1065567-A	50
			PGAA60E1K3	1068368	76
			PGAA60E2K1	1065567-A	50
			PGAA60G1K1	1065575-A	50
			PGAA60G1K3	1067989	75
			PGAA60G2K1	1065575-A	50

MODEL NUMBER	TECH. SHEET	PAGE	MODEL NUMBER	TECH. SHEET	PAGE
PGAB			PGMD		
PGAB18B1K1	1066136	54	PGMD18G040	7212097-A	77
PGAB18C1K1	1066215	54	PGMD18G0401	7212097-A	77
			PGMD18G0402	7212109-A	81
PGAB24B1K1	1065848-A	51	PGMD24G060	7212097-A	77
PGAB24C1K1	1065849-A	51	PGMD24G0601	7212097-A	77
PGAB24D1K1	1065850-A	52	PGMD24G0602	7212109-A	81
			PGMD24G075	7212097-A	77
PGAB30C1K1	1065113	40	PGMD24G0751	7212097-A	77
PGAB30D1K1	1065170	41	PGMD24G0752	7212109-A	81
			PGMD30G060	7212097-A	77
PGAB36C1K1	1065956	52	PGMD30G0601	7212097-A	77
PGAB36D1K1	1065957	53	PGMD30G0602	7212109-A	81
PGAB36E1K1	1065958	53	PGMD30G075	7212097-A	77
			PGMD30G0751	7212097-A	77
			PGMD30G0752	7212109-A	81
PGAD					
PGAD24B1K1	1066616	57	PGMD36G060	7212097-A	77
PGAD24B1K3	1067920	66	PGMD36G0601	7212097-A	77
PGAD24D1K1	1066617	57	PGMD36G0602	7212109-A	81
PGAD24D1K3	1067921	66	PGMD36G075	7212097-A	77
			PGMD36G0751	7212097-A	77
PGAD30D1K1	1066618	58	PGMD36G0752	7212109-A	
PGAD30D1K3	1067922	67			
			PGMD36G095	7212097-A	77
PGAD36D1K1	1066619	58	PGMD36G0951	7212097-A	77
PGAD36D1K2	1066619	58	PGMD36G0952	7212109-A	81
PGAD36D1K3	1067923	67			
PGAD36E1K1	1066620	59	PGMD42G115	7212097-B	78
PGAD36E1K3	1067924	68	PGMD42G1151	7212097-B	78
			PGMD42G1152	7212109-B	82
PGAD42D1K1	1066945	61			
PGAD42D1K3	1067958	71	PGMDE48G090	7212097-B	78
PGAD42E1K1	1066946	62	PGMD48G0901	7212097-B	78
PGAD42E1K3	1067959	71	PGMD48G0902	7212109-B	82
			PGMD48G135	7212097-B	78
PGAD47D1K1	1066943	60	PGMD48G1351	7212097-B	78
PGAD47D1K3	1067963	72	PGMD48G1352	7212109-B	82
PGAD47F1K1	1066944	61			
PGAD47F1K3	1067964	72	PGMD60G115	7212097-B	78
			PGMD60G1151	7212097-B	78
PGAD60E1K1	1066941	59	PGMD60G1152	7212109-B	82
PGAD60E1K3	1067965	73	PGMD60G150	7212097-B	78
PGAD60G1K1	1066942	60	PGMD60G1501	7212097-B	78
PGAD60G1K3	1067966	73	PGMD60G1502	7212109-B	82

MODEL NUMBER	TECH. SHEET	PAGE	MODEL NUMBER	TECH. SHEET	PAGE
PGME			PGME42G075	7212097-D	80
			PGME42G0751	7212097-D	80
			PGME42G0752	7212109-D	84
PGME24G040	7212097-C	79			
PGME24G0401	7212097-C	79	PGME42G115	7212097-D	80
PGME24G0402	7212109-C	83	PGME42G1151	7212097-D	80
PGME24G075	7212097-C	79	PGME42G1152	7212109-D	84
PGME24G0751	7212097-C	79			
PGME24G0752	7212109-C	83			
			PGME48G090	7212097-D	80
PGME30G075	7212097-C	79	PGME48G0901	7212097-D	80
PGME30G0751	7212097-C	79	PGME48G0902	7212109-D	84
PGME30G0752	7212109-C	83	PGME48G135	7212097-D	80
			PGME48G1351	7212097-D	80
PGME36G075	7212097-C	79	PGME48G1352	7212109-D	84
PGME36G0751	7212097-C	79			
PGME36G0752	7212109-C	83	PGME60G115	7212097-D	80
			PGME60G1151	7212097-D	80
PGME36G095	7212097-C	79	PGME60G1152	7212109-D	84
PGME36G0951	7212097-C	79	PGME60G150	7212097-D	80
PGME36G0952	7212109-C	83	PGME60G1501	7212097-D	80
			PGME60G1502	7212109-D	84

Technical Service Data Sheets 1054587 & 1065113

Model or Style No. PGAA47D1K		Performance Data: 805F Dry Bulb Indoor											
Specifications		Coil - Internal Rated 1600 CFM .20 ESP Wet.											
		Low Wet Bulb (635F)					High Wet Bulb (695F)						
		Ambient Outdoor 5F	Approx. MBTUH	Sens. Total Ratio	PSIG. Liquid (Head)	PSIG. Suct.	Unit Amps	Ambient Outdoor 5F	Approx. MBTUH	Sens. Total Ratio	PSIG. Liquid (Head)	PSIG. Suct.	Unit Amps
Electrical: Voltage-Phase-Hz Branch Circuit Ampacity Wire Size/Max. Ft. Time Delay/HACR Brkr. Max. Fuse Boost Transformer	208/230-1-60 35.8 No. 6 / 97' 45 50 --	65	48.3	0.86	183	61	20.2	65	52.9	0.60	198	70	21.3
		75	47.3	0.88	205	64	21.6	75	51.7	0.62	221	74	22.8
		85	46.5	0.90	233	68	23.0	85	50.8	0.64	251	77	24.3
		95	45.3	0.92	265	71	24.4	95	49.5	0.65	286	81	25.8
		105	43.1	0.93	297	74	25.8	105	47.2	0.66	321	84	27.2
115	39.4	0.93	328	77	27.2	115	43.2	0.66	354	87	28.7		
Fan Motor: H.P./Type FLA/LRA Speeds/CFM Cap. MFD/Volts	COND. 1/2 PSC 1.8 / 6.42 1 / 4500 7.5 / 440	EVAP. 1/2 PSC 4.4 / 7.80 4 / 1860 15 / 370	Heating Data					Blower Performance Data (Add 0.05 In. W.C. for wet coil)					
Compressor: FLA/LRA Run Cap. MFD./Volts Acc. Start Kit	COPELAND 23.7 / 129 40 / 440 NAMA001SC		Gas Type	Nat			External Static Pressure Inches of W. C.	CFM @ 230V - Dry Coil (no filter)					
Service Driers: Liquid/Charge Suction	30 cu in / 17oz 30 sq in		Input (MBTUH)	90 / 75				TAP	LOW	MED L	MED H	HIGH	
			Output (MBTUH)	71 / 60				.10	1485	1570	1785	1925	
			Gas Valve	HW				.20	1460	1540	1735	1860	
			Regulation Type	Snap				.30	1430	1505	1680	1795	
			Manifold Pressure	3.5				.40	1395	1465	1620	1725	
			Orifices	43/46				.50	1345	1415	1560	1650	
			Pilot Orifice Size	.018				.60	1290	1350	1485	1570	
Temp. Rise 0F	30-60			.70	1225	1280		1405	1485				
Ignition Type	IID			CFM @ 208V - Dry Coil (no filter)									
Fan Control (ON/OFF)	TIME			TAP	LOW	MED L		MED H	HIGH				
Limit Control (MAX)	135			.10	1270	1385		1610	1805				
Heat Anticipator	.58			.20	1265	1355		1580	1755				
Ref. Charge (R-22 Oz.)	124			.30	1250	1330		1540	1700				
Clearances See Installation Instructions								.40	1225	1300	1495	1640	
							.50	1190	1265	1440	1575		
							.60	1140	1215	1375	1500		
								.70	1085	1155	1300	1415	

Note: Optimum operating charge will produce 15⁰ - 25⁰ F suction line superheat at compressor with 82⁰ F outdoor ambient and 80⁰ F dry bulb (67⁰ F wet bulb) indoor temperature at rated airflow.

1054587
11-13-92
AH-1

Model or Style No. PGAB30C1K		Performance Data: 80 ⁰ D.B. Indoor											
Specifications		Coil - Internal Rated 1000 CFM .40 ESP Wet.											
		Low Wet Bulb (63 ⁰)					High Wet Bulb (69 ⁰)						
		Ambient Outdoor 5F	Approx. MBTUH	Sens. Total Ratio	PSIG. Liquid (Head)	PSIG. Suct.	Unit Amps	Ambient Outdoor 5F	Approx. MBTUH	Sens. Total Ratio	PSIG. Liquid (Head)	PSIG. Suct.	Unit Amps
Electrical: Voltage/Cycles/Phase Branch Circuit Ampacity Wire Size/Max. Ft. Time Delay Fuse Size Max. Fuse/HACR Brkr. Boost Transformer	208/230/60/1 20.5 No. 12 / 40' 25 30 -	65	29.2	0.89	168	64	11.6	65	31.9	0.63	182	73	12.3
		75	28.6	0.91	188	68	12.4	75	31.3	0.65	203	78	13.1
		85	28.1	0.93	214	71	13.3	85	30.7	0.67	231	81	14.0
		95	27.3	0.95	243	75	14.1	95	29.9	0.68	262	85	14.8
		105	26.1	0.96	273	78	14.9	105	28.5	0.69	295	89	15.7
115	23.8	0.96	302	81	15.7	115	26.1	0.69	326	92	16.5		
Fan Motor: H.P./Type FLA/LRA Speeds/CFM Cap. MFD/Volts	COND. 1/3 PSC 1.4/3.57 1/3000 5/370	EVAP. 1/3PSC 2.3/4.10 3/1175 7.5/370	Heating					230V - Dry Coil					
Compressor: FLA/LRA Run Cap. MFD./Volts Acc. Start Kit	COPELAND 13.5 / 76.0 35/370 NAMA001SC		Gas Type	Nat			External Static Pressure Inches of W. C.	TAP	LOW	MED L	MED H	HIGH	
Service Driers: Liquid/Charge Suction	8 cu in / 7oz 30 sq in		Input (MBTUH)	60				.10	-	-	-	-	
			Output (MBTUH)	47				.20	790	-	955	1175	
			Gas Valve	HW				.30	760	-	915	1120	
			Regulation Type	Snap				.40	730	-	870	1055	
			Manifold Pressure	3.5				.50	690	-	815	990	
			Orifices	44				.60	645	-	755	920	
			Pilot Orifice Size	.018				.70	585	-	685	840	
Temp. Rise 0F	45-75			208V - Dry Coil									
Ignition Type	IID			TAP	LOW	MED L		MED H	HIGH				
Fan Control (ON/OFF)	TIME			.10	-	-		-	-				
Limit Control (MAX)	150			.20	670	-		825	1090				
Heat Anticipator	.58			.30	645	-		790	1040				
Ref. Charge (R-22 Oz.)	74			.40	620	-		750	985				
Clearances See Installation Instructions								.50	585	-	705	925	
							.60	540	-	650	855		
							.70	485	-	580	780		

Note: Optimum operating charge will produce 15⁰ - 25⁰ F suction line superheat at compressor with 82⁰ F outdoor Ambient and 80⁰ F, Dry Bulb (67⁰ F, Wet Bulb) indoor temperature at rated airflow.

1065113
10-15-91
AH-2

Technical Service Data Sheets 1065170 & 1065307-A

Model or Style No. PGAB30D1K		Performance Data: 80° D.B. Indoor											
Specifications		Low Wet Bulb (63°)					High Wet Bulb (69°)						
		Coil - Internal					Rated 1000 CFM .40 ESP Wet.						
		Ambient Outdoor 5F	Approx. MBTUH	Sens. Total Ratio	PSIG. Liquid (Head)	PSIG. Suct.	Unit Amps	Ambient Outdoor 5F	Approx. MBTUH	Sens. Total Ratio	PSIG. Liquid (Head)	PSIG. Suct.	Unit Amps
Electrical: Voltage/Cycles/Phase Branch Circuit Ampacity Wire Size/Max. Ft. Time Delay Fuse Size Max. Fuse/HACR Brk. Boost Transformer	208/230/60/1 20.5 No. 12 / 40' 25 30 -	65	29.2	0.89	168	64	11.6	65	31.9	0.63	182	73	12.3
		75	28.6	0.91	188	68	12.4	75	31.3	0.65	203	78	13.1
		85	28.1	0.93	214	71	13.3	85	30.7	0.67	231	81	14.0
		95	27.3	0.95	243	75	14.1	95	29.9	0.68	262	85	14.8
		105	26.1	0.96	273	78	14.9	105	28.5	0.69	295	89	15.7
		115	23.8	0.96	302	81	15.7	115	26.1	0.69	326	92	16.5
Fan Motor: H.P./Type FLA/LRA Speeds/CFM Cap. MFD/Volts	COND. EVAP. 1/3 PSC 1/3PSC 1.4/3.57 2.3/4.10 1/3000 3/1175 5/370 7.5/370	Heating											
		Gas Type					230V - Dry Coil						
Compressor: FLA/LRA Run Cap. MFD./Volts Acc. Start Kit	COPELAND 13.5 / 76.0 35/370 NAMA001SC	Gas Type					External Static Pressure						
		Input (MBTUH)					Inches of W. C.						
Output (MBTUH)													
Gas Valve													
Regulation Type													
Manifold Pressure													
Orifices													
Pilot Orifice Size													
Temp. Rise 0F													
Ignition Type													
Fan Control (ON/OFF)													
Limit Control (MAX)													
Heat Anticipator													
Service Driers: Liquid/Charge Suction		8 cu in / 7oz 30 sq in											
Ref. Charge (R-22 Oz.)		74											
Clearances See Installation Instructions													

Note: Optimum operating charge will produce 15° - 25° F suction line superheat at compressor with 82° F outdoor Ambient and 80° F, Dry Bulb (67° F, Wet Bulb) indoor temperature at rated airflow.

1065170
10-15-91
AH-2

Model or Style No. PGAA29C1K		Performance Data: 80° D.B. Indoor											
Specifications		Low Wet Bulb (63°)					High Wet Bulb (69°)						
		Coil - Internal					Rated 1000 CFM .40 ESP Wet.						
		Amb. Outd	Appx. MBTUH	Sens. Total Ratio	PSIG. Disch. (Head)	PSIG. Suct.	Unit Amp.	Amb. Outd	Appx. MBTUH	Sens. Total Ratio	PSIG. Disch. (Head)	PSIG. Suct.	Unit Amp.
Electrical: Voltage/Cycles/Phase Branch Circuit Ampacity Wire Size/Max. Ft. Time Delay Fuse Size Max. Fuse/HACR Brk. Boost Transformer	208/230/60/1 20.5 No. 10 / 60' 25 30 -	65	29.2	0.89	168	64	11.6	65	31.9	0.63	182	73	12.3
		75	28.6	0.91	188	68	12.4	75	31.3	0.65	203	78	13.1
		85	28.1	0.93	214	71	13.3	85	30.7	0.67	231	81	14.0
		95	27.3	0.95	243	75	14.1	95	29.9	0.68	262	85	14.8
		105	26.1	0.96	273	78	14.9	105	28.5	0.69	295	89	15.7
		115	23.8	0.96	302	81	15.7	115	26.1	0.69	326	92	16.5
Fan Motor: H.P./Type FLA/LRA Speeds/CFM Cap. MFD/Volts	COND. EVAP. 1/3 PSC 1/3PSC 1.4/3.57 2.3/4.10 1/3000 3/1175 5/370 7.5/370	Heating											
		Gas Type					230V - Dry Coil						
Compressor: FLA/LRA Run Cap. MFD./Volts Acc. Start Kit	COPELAND 13.5 / 76.0 35/370 NAMA001SC	Gas Type					External Static Pressure						
		Input (MBTUH)					Inches of W. C.						
Output (MBTUH)													
Gas Valve													
Regulation Type													
Manifold Pressure													
Orifices													
Pilot Orifice Size													
Temp. Rise 0F													
Ignition Type													
Fan Control (ON/OFF)													
Limit Control (MAX)													
Heat Anticipator													
Service Driers: Liquid/Charge Suction		8 cu in / 7oz 30 sq in											
Ref. Charge (R-22 Oz.)		74											
Clearances See Installation Instructions													

Note: Optimum operating charge will produce 15° - 25° F suction line superheat at compressor with 82° F outdoor Ambient and 80° F, Dry Bulb (67° F, Wet Bulb) indoor temperature at rated airflow.

1065307-A
7-22-91
AH-2

Technical Service Data Sheets 1065408-A & 1065409-A

Model or Style No. PGAA18B1K		Performance Data: 80° D.B. Indoor											
Specifications		Coil – Internal					Rated 600 CFM .15 ESP Wet.						
		Low Wet Bulb (63°)					High Wet Bulb (69°)						
		Amb. Outd	Appx. MBTUH	Sens. Total Ratio	PSIG. Disch. (Head)	PSIG. Suct.	Unit Amp.	Amb. Outd	Appx. MBTUH	Sens. Total Ratio	PSIG. Disch. (Head)	PSIG. Suct.	Unit Amp.
Electrical: Voltage/Cycles/Phase Branch Circuit Ampacity Wire Size/Max. Ft. Time Delay Fuse Size Max. Fuse/HACR Brk. Boost Transformer	208/230–1–60 14.0 No. 14 / 40' 20 20 –	65	18.7	.86	165	63	7.2	65	20.5	.60	178	72	7.6
		75	18.3	.88	184	67	7.7	75	20.0	.62	199	76	8.1
		85	18.0	.90	210	70	8.2	85	19.7	.64	226	80	8.7
		95	17.5	.92	238	73	8.7	95	19.2	.65	257	84	9.2
		105	16.7	.93	268	76	9.2	105	18.3	.66	289	87	9.7
		115	15.3	.93	296	79	9.7	115	16.7	.66	319	90	10.2
Fan Motor: H.P./Type FLA/LRA Speeds/CFM Cap.MFD/Volts	COND. EVAP. 1/6PSC 1/6PSC .8/1.72 1.5/1.81 1/2250 3/820 5/370 5/370	Heating Performance Data					Blower Performance Data (Add 0.05 In. W.C. for Wet Coil)						
Compressor: FLA/LRA Run Cap. MFD./Volts Acc. Start Kit	COPELAND 9.4/49 25/370 NAMA001SC	Gas Type	Nat				External Static Pressure Inches of W. C.	CFM @ 230V – Dry Coil (No Filter)					
Service Driers: Liquid/Charge Suction	5 cu in / 5oz 17 sq in	Input (MBTUH)	40					TAP	LOW	MED L	MED H	HIGH	
Ref. Charge (R-22 Oz.) 57		Output (MBTUH)	31					.10	–	–	–	–	
		Gas Valve	HW					.20	615	–	750	820	
		Regulation Type	Snap					.30	585	–	715	785	
		Manifold Pressure	3.5					.40	550	–	685	750	
		Orifices	44					.50	515	–	645	715	
		Pilot Orifice Size	.018					.60	470	–	600	670	
Clearances See Installation Instructions		Temp. Rise 0F	30–60					.70	415	–	550	615	
		Ignition Type	IID					CFM @ 208V – Dry Coil (No Filter)					
		Fan Control (ON/OFF)	TIME				TAP	LOW	MED L	MED H	HIGH		
		Limit Control (MAX)	160				.10	–	–	–	–		
		Heat Anticipator	.58				.20	530	–	660	730		
				.30	505	–	630	700	.40	475	–	600	670
		.50	440	–	570	635	.60	390	–	525	590		
		.70	330	–	470	535							

Note: Optimum operating charge will produce 15°–25° F suction line superheat at compressor with 82° F outdoor ambient and 80° F Dry Bulb (67° F Wet Bulb) indoor temperature at rated air flow.

1065408-A
7-15-91
AH-2

Model or Style No. PGAA18C1K		Performance Data: 80° D.B. Indoor											
Specifications		Coil – Internal					Rated 600 CFM .15 ESP Wet.						
		Low Wet Bulb (63°)					High Wet Bulb (69°)						
		Amb. Outd	Appx. MBTUH	Sens. Total Ratio	PSIG. Disch. (Head)	PSIG. Suct.	Unit Amp.	Amb. Outd	Appx. MBTUH	Sens. Total Ratio	PSIG. Disch. (Head)	PSIG. Suct.	Unit Amp.
Electrical: Voltage/Cycles/Phase Branch Circuit Ampacity Wire Size/Max. Ft. Time Delay Fuse Size Max. Fuse/HACR Brk. Boost Transformer	208/230/60/1 14.0 No. 14 / 40' 20 20 –	65	18.7	.86	165	63	7.2	65	20.5	.60	178	72	7.6
		75	18.3	.88	184	67	7.7	75	20.0	.62	199	76	8.1
		85	18.0	.90	210	70	8.2	85	19.7	.64	226	80	8.7
		95	17.5	.92	238	73	8.7	95	19.2	.65	257	84	9.2
		105	16.7	.93	268	76	9.2	105	18.3	.66	289	87	9.7
		115	15.3	.93	296	79	9.7	115	16.7	.66	319	90	10.2
Fan Motor: H.P./Type FLA/LRA Speeds/CFM Cap. MFD/Volts	COND. EVAP. 1/6 PSC 1/6 PSC .8/1.72 1.5/1.81 1/2250 3/820 5/370 5/370	Heating					Blower Performance Data (Add 0.05 In. W.C. for Wet Coil)						
Compressor: FLA/LRA Run Cap. MFD./Volts Acc. Start Kit	COPELAND 9.4/49 25/370 NAMA001SC	Gas Type	Nat				External Static Pressure Inches of W. C.	230V – Dry Coil					
Service Driers: Liquid/Charge Suction	5 cu in / 5oz 17 sq in	Input (MBTUH)	60					TAP	LOW	MED L	MED H	HIGH	
Ref. Charge (R-22 Oz.) 57		Output (MBTUH)	47					.10	–	–	–	–	
		Gas Valve	HW					.20	615	–	750	820	
		Regulation Type	Snap					.30	585	–	715	785	
		Manifold Pressure	3.5					.40	550	–	685	750	
		Orifices	44					.50	515	–	645	715	
		Pilot Orifice Size	.018					.60	470	–	600	670	
Clearances See Installation Instructions		Temp. Rise 0F	45–75					.70	415	–	550	615	
		Ignition Type	IID					208V – Dry Coil					
		Fan Control (ON/OFF)	TIME				TAP	LOW	MED L	MED H	HIGH		
		Limit Control (MAX)	135				.10	–	–	–	–		
		Heat Anticipator	.58				.20	530	–	660	730		
				.30	505	–	630	700	.40	475	–	600	670
		.50	440	–	570	635	.60	390	–	525	590		
		.70	330	–	470	535							

Note: Optimum operating charge will produce 15°–25° F suction line superheat at compressor with 82° F outdoor Ambient and 80° F, Dry Bulb (67° F, Wet Bulb) indoor temperature at rated airflow.

1065409-A
7-15-91
AH-2

Technical Service Data Sheets 1065410 & 1065411

Model or Style No. G4P024A3A1 – PGAA24B1K

Specifications		Performance Data: 80° D.B. Indoor												
		Low Wet Bulb (63°)					High Wet Bulb (69°)							
		Coil – Internal					Rated 800 CFM .15 ESP Wet.							
		Amb. Outd	Appx. MBTUH	Sens. Total Ratio	PSIG. Disch. (Head)	PSIG. Suct.	Unit Amp.	Amb. Outd	Appx. MBTUH	Sens. Total Ratio	PSIG. Disch. (Head)	PSIG. Suct.	Unit Amp.	
Electrical: Voltage/Cycles/Phase Branch Circuit Ampacity Wire Size/Max. Ft. Time Delay Fuse Size Max. Fuse/HACR Brk. Boost Transformer	208/230/60/1 16.8 No. 12 / 50' 20 25 -- -- --	65	24.8	.86	180	64	9.9	65	27.1	.60	194	73	10.4	
		75	24.2	.88	201	68	10.6	75	26.5	.62	217	77	11.1	
		85	23.8	.90	229	71	11.2	85	26.1	.64	247	81	11.9	
		95	23.2	.92	261	74	11.9	95	25.4	.65	281	85	12.6	
		105	22.1	.93	293	77	12.6	105	24.2	.66	316	88	13.3	
Fan Motor: H.P./Type FLA/LRA Speeds/CFM Cap. MFD/Volts	COND. 1/6 PSC EVAP. 1/4PSC	115	20.2	.93	323	80	13.3	115	22.1	.66	349	92	14.0	
Compressor: FLA/LRA Run Cap. MFD./Volts Acc. Start Kit		COPELAND 11.2 / 61 35/370 NAMA001SC		Gas Type Input (MBTUH) Output (MBTUH)		Nat 40 31		External Static Pressure Inches of W. C.		230V – Dry Coil				
Service Driers: Liquid/Charge Suction		8 cu in / 7oz 30 sq in		Gas Valve Regulation Type Manifold Pressure		HW Snap 3.5				TAP	LOW	MED L	MED H	HIGH
Ref. Charge (R-22 Oz.)		64		Orifices Pilot Orifice Size		44 .018				.10	–	–	–	–
Clearances See Installation Instructions				Temp. Rise 0F Ignition Type Fan Control (ON/OFF)		30–60 IID TIME				.20	620	725	825	995
				Limit Control (MAX) Heat Anticipator		160 .58				.30	605	705	805	960
										.40	585	675	775	925
										.50	565	650	745	880
										.60	530	615	705	835
										.70	485	570	660	780
										208V – Dry Coil				
								TAP	LOW	MED L	MED H	HIGH		
								.10	–	–	–	–		
								.20	535	620	725	890		
								.30	520	600	700	860		
								.40	500	580	670	830		
								.50	475	550	635	790		
								.60	435	515	600	750		
								.70	385	470	555	705		
Note: Optimum operating charge will produce 15° – 25° F suction line superheat at compressor with 82° F outdoor Ambient and 80° F, Dry Bulb (67° F, Wet Bulb) indoor temperature at rated airflow.										1065410 9–16–91 AH–3				

Model or Style No. G4P024A3B1 – PGAA24C1K

Specifications		Performance Data: 80° D.B. Indoor												
		Low Wet Bulb (63°)					High Wet Bulb (69°)							
		Coil – Internal					Rated 800 CFM .15 ESP Wet.							
		Amb. Outd	Appx. MBTUH	Sens. Total Ratio	PSIG. Disch. (Head)	PSIG. Suct.	Unit Amp.	Amb. Outd	Appx. MBTUH	Sens. Total Ratio	PSIG. Disch. (Head)	PSIG. Suct.	Unit Amp.	
Electrical: Voltage/Cycles/Phase Branch Circuit Ampacity Wire Size/Max. Ft. Time Delay Fuse Size Max. Fuse/HACR Brk. Boost Transformer	208/230/60/1 16.8 No. 12 / 50' 20 25 -- -- --	65	24.8	.86	180	64	9.9	65	27.1	.60	194	73	10.4	
		75	24.2	.88	201	68	10.6	75	26.5	.62	217	77	11.1	
		85	23.8	.90	229	71	11.2	85	26.1	.64	247	81	11.9	
		95	23.2	.92	261	74	11.9	95	25.4	.65	281	85	12.6	
		105	22.1	.93	293	77	12.6	105	24.2	.66	316	88	13.3	
Fan Motor: H.P./Type FLA/LRA Speeds/CFM Cap. MFD/Volts	COND. 1/6 PSC EVAP. 1/4PSC	115	20.2	.93	323	80	13.3	115	22.1	.66	349	92	14.0	
Compressor: FLA/LRA Run Cap. MFD./Volts Acc. Start Kit		COPELAND 11.2 / 61 35/370 NAMA001SC		Gas Type Input (MBTUH) Output (MBTUH)		Nat 60 47		External Static Pressure Inches of W. C.		230V – Dry Coil				
Service Driers: Liquid/Charge Suction		8 cu in / 7oz 30 sq in		Gas Valve Regulation Type Manifold Pressure		HW Snap 3.5				TAP	LOW	MED L	MED H	HIGH
Ref. Charge (R-22 Oz.)		64		Orifices Pilot Orifice Size		44 .018				.10	–	–	–	–
Clearances See Installation Instructions				Temp. Rise 0F Ignition Type Fan Control (ON/OFF)		45–75 IID TIME				.20	620	725	825	995
				Limit Control (MAX) Heat Anticipator		150 .58				.30	605	705	805	960
										.40	585	675	775	925
										.50	565	650	745	880
										.60	530	615	705	835
										.70	485	570	660	780
										208V – Dry Coil				
								TAP	LOW	MED L	MED H	HIGH		
								.10	–	–	–	–		
								.20	535	620	725	890		
								.30	520	600	700	860		
								.40	500	580	670	830		
								.50	475	550	635	790		
								.60	435	515	600	750		
								.70	385	470	555	705		
Note: Optimum operating charge will produce 15° – 25° F suction line superheat at compressor with 82° F outdoor Ambient and 80° F, Dry Bulb (67° F, Wet Bulb) indoor temperature at rated airflow.										1065411 9–16–91 AH–3				

Technical Service Data Sheets 1065412-B & 1065413-B

Model or Style No. PGAA24D1K		Performance Data: 80° D.B. Indoor											
Specifications		Low Wet Bulb (63°)					High Wet Bulb (69°)						
Electrical: Voltage/Cycles/Phase Branch Circuit Ampacity Wire Size/Max. Ft. Time Delay Fuse Size Max. Fuse/HACR Brk. Boost Transformer	208/230/60/1 17.0 No. 12 / 50' 20 25 ---	Coil – Internal					Rated 800 CFM .15 ESP Wet.						
		Amb. Outd.	Appx. MBTUH	Sens. Total Ratio	PSIG. Disch. (Head)	PSIG. Suct.	Unit Amp.	Amb. Outd.	Appx. MBTUH	Sens. Total Ratio	PSIG. Disch. (Head)	PSIG. Suct.	Unit Amp.
		65	24.8	.86	180	64	9.8	65	27.1	.60	194	73	10.3
		75	24.2	.88	201	68	10.5	75	26.5	.62	217	77	11.0
		85	23.8	.90	229	71	11.2	85	26.1	.64	247	81	11.8
Fan Motor: H.P./Type FLA/LRA Speeds/CFM Cap. MFD/Volts	COND. EVAP. 1/6 PSC 1/3PSC .8/1.72 2.3/4.10 1/2250 3/1175 5/370 7.5/370	105	22.1	.93	293	77	12.5	105	24.2	.66	316	88	13.2
		115	20.2	.93	323	80	13.2	115	22.1	.66	349	92	13.9
		Heating											
Compressor: FLA/LRA Run Cap. MFD./Volts Acc. Start Kit	COPELAND 11.2 / 61 35/370 NAMA001SC	Gas Type Input (MBTUH) Output (MBTUH) Gas Valve Regulation Type Manifold Pressure Orifices Pilot Orifice Size Temp. Rise 0F Ignition Type Fan Control (ON/OFF) Limit Control (MAX) Heat Anticipator	Nat 90/75 70/59 HW Snap 3.5 43/46 .018 45-75 IID TIME 135 .58	External Static Pressure Inches of W. C.	230V – Dry Coil								
					TAP	LOW	MED L	MED H	HIGH				
Service Driers: Liquid/Charge Suction	8 cu in / 7oz 30 sq in				208V – Dry Coil								
					TAP	LOW	MED L	MED H	HIGH				
Ref. Charge (R-22 Oz.)	64												
					TAP	LOW	MED L	MED H	HIGH				
Clearances See Installation Instructions													
					TAP	LOW	MED L	MED H	HIGH				
Note: Optimum operating charge will produce 15° – 25° F suction line superheat at compressor with 82° F outdoor Ambient and 80° F, Dry Bulb (67° F, Wet Bulb) indoor temperature at rated airflow.										1065412-B 9-16-91 AH-3			

Model or Style No. PGAA30C1K		Performance Data: 80° D.B. Indoor											
Specifications		Low Wet Bulb (63°)					High Wet Bulb (69°)						
Electrical: Voltage/Phase/Hz Branch Circuit Ampacity Wire Size/Max. Ft. Time Delay Fuse Size Max. Fuse/HACR Brk. Boost Transformer	208/230-1-60 21.6 30 35 ---	Coil – Internal					Rated 1000 CFM .40 ESP Wet.						
		Amb. Outd.	Appx. MBTUH	Sens. Total Ratio	PSIG. Disch. (Head)	PSIG. Suct.	Unit Amp.	Amb. Outd.	Appx. MBTUH	Sens. Total Ratio	PSIG. Disch. (Head)	PSIG. Suct.	Unit Amp.
		65	30.8	.86	169	63	12.0	65	33.7	.60	183	72	12.7
		75	30.1	.88	190	66	12.9	75	33.0	.62	205	76	13.6
		85	29.6	.90	216	70	13.7	85	32.4	.64	233	79	14.5
Fan Motor: H.P./Type FLA/LRA Speeds/CFM Cap. MFD/Volts	COND. EVAP. 1/3 PSC 1/3PSC 1.4/3.57 2.3/4.10 1/3000 3/1175 5/370 7.5/370	105	28.9	.92	245	73	14.6	105	31.6	.65	264	83	15.3
		115	27.5	.93	275	76	15.4	115	30.1	.66	297	87	16.2
		115	25.1	.93	304	79	16.2	115	27.5	.66	328	90	17.1
Heating Performance Data													
Compressor: FLA/LRA Run Cap. MFD./Volts Acc. Start Kit	COPELAND 14.4/82 35/370 NAMA001SC	Gas Type Input (MBTUH) Output (MBTUH) Gas Valve Regulation Type Manifold Pressure Orifices Pilot Orifice Size Temp. Rise 0F Ignition Type Fan Control (ON/OFF) Limit Control (MAX) Heat Anticipator	Nat 60 47 HW Snap 3.5 44 .018 45-75 IID TIME 150 .58	External Static Pressure Inches of W. C.	Blower Performance Data (Add 0.05 In. W.C. for Wet Coil)								
					CFM @ 230V – Dry Coil (No Filter)								
Service Driers: Liquid/Charge Suction	8 cu in / 7oz 30 sq in				CFM @ 208V – Dry Coil (No Filter)								
					TAP	LOW	MED L	MED H	HIGH				
Ref. Charge (R-22 Oz.)	75												
					TAP	LOW	MED L	MED H	HIGH				
Clearances See Installation Instructions													
					TAP	LOW	MED L	MED H	HIGH				
Note: Optimum operating charge will produce 15° – 25° F suction line superheat at compressor with 82° F outdoor ambient and 80° F Dry Bulb (67° F Wet Bulb) indoor temperature at rated airflow.										1065413-B 9-4-92 AH-3			

Technical Service Data Sheets 1065414-A & 1065415-B

Model or Style No. PGAA30D1K		Performance Data: 80° D.B. Indoor																																		
Specifications		Coil – Internal																																		
		Low Wet Bulb (63°)					High Wet Bulb (69°)																													
		Amb. Outd.	Appx. MBTUH	Sens. Total Ratio	PSIG. Disch. (Head)	PSIG. Suct.	Unit Amp.	Amb. Outd.	Appx. MBTUH	Sens. Total Ratio	PSIG. Disch. (Head)	PSIG. Suct.	Unit Amp.																							
Electrical: Voltage/Phase/Hz Branch Circuit Ampacity Wire Size/Max. Ft. Time Delay Fuse Size Max. Fuse/HACR Brk. Boost Transformer	208/230–1–60 21.6 No. 10 / 60' 30 35 –	65	30.8	.86	169	63	12.0	65	33.7	.60	183	72	12.7																							
		75	30.1	.88	190	66	12.9	75	33.0	.62	205	76	13.6																							
		85	29.6	.90	216	70	13.7	85	32.4	.64	233	79	14.5																							
		95	28.9	.92	245	73	14.6	95	31.6	.65	264	83	15.3																							
		105	27.5	.93	275	76	15.4	105	30.1	.66	297	87	16.2																							
		115	25.1	.93	304	79	16.2	115	27.5	.66	328	90	17.1																							
Fan Motor: H.P./Type FLA/LRA Speeds/CFM Cap. MFD/Volts	COND. EVAP. 1/3 PSC 1/3PSC 1.4/3.57 2.3/4.10 1/3000 3/1175 5/370 7.5/370	Blower Performance Data (Add 0.05 In. W.C. for Wet Coil)																																		
												Heating Performance Data																								
Compressor: FLA/LRA Run Cap. MFD./Volts Acc. Start Kit	COPELAND 14.4/82 35/370 NAMA001SC	Gas Type	Nat	Input (MBTUH)	90/75	Output (MBTUH)	70/59	Gas Valve	HW	Regulation Type	Snap	Manifold Pressure	3.5	Orifices	43/46	Pilot Orifice Size	.018	Temp. Rise 0F	45–75	Ignition Type	IID	Fan Control (ON/OFF)	TIME	Limit Control (MAX)	135	Heat Anticipator	.58	CFM @ 230V – Dry Coil (No Filter)								
																												TAP	LOW	MED L	MED H	HIGH				
Service Driers: Liquid/Charge Suction	8 cu in / 7oz 30 sq in	Ref. Charge (R-22 Oz.)	75	Clearances See Installation Instructions						External Static Pressure Inches of W. C.					.10	–	–	–	–																	
															.20	790	–	955	1175																	
																												CFM @ 208V – Dry Coil (No Filter)								
																														TAP	LOW	MED L	MED H	HIGH		
																																.10	–	–	–	–
																																.20	670	–	825	1090
																																.30	645	–	790	1040
																																.40	620	–	750	985
																																.50	585	–	705	925
																																.60	540	–	650	855
																																.70	485	–	580	780

Note: Optimum operating charge will produce 15° – 25° F suction line superheat at compressor with 82° F outdoor ambient and 80° F Dry Bulb (67° F Wet Bulb) indoor temperature at rated airflow.

1065414-A
7-15-91
AH-2

Model or Style No. PGAA36C1K		Performance Data: 80° D.B. Indoor																																				
Specifications		Coil – Internal																																				
		Low Wet Bulb (63°)					High Wet Bulb (69°)																															
		Amb. Outd.	Appx. MBTUH	Sens. Total Ratio	PSIG. Disch. (Head)	PSIG. Suct.	Unit Amp.	Amb. Outd.	Appx. MBTUH	Sens. Total Ratio	PSIG. Disch. (Head)	PSIG. Suct.	Unit Amp.																									
Electrical: Voltage/Cycles/Phase Branch Circuit Ampacity Wire Size/Max. Ft. Time Delay Fuse Size Max. Fuse/HACR Brk. Boost Transformer	208/230/60/1 27.4 No. 10 / 50' 35 45 – – – –	65	34.6	.87	178	65	13.6	65	37.9	.61	192	74	14.3																									
		75	33.9	.89	199	68	14.6	75	37.1	.63	214	78	15.3																									
		85	33.3	.91	226	72	15.5	85	36.4	.65	244	82	16.3																									
		95	32.4	.93	257	75	16.4	95	35.5	.66	277	86	17.3																									
		105	30.9	.94	289	78	17.4	105	33.8	.67	311	89	18.3																									
		115	28.3	.94	318	81	18.3	115	30.9	.67	344	93	19.3																									
Fan Motor: H.P./Type FLA/LRA Speeds/CFM Cap. MFD/Volts	COND. EVAP. 1/3 PSC 1/2 PSC 1.4/13.57 3.6/7.5 1/3000 3/1435 5/370 15/370	Heating																																				
												Compressor:																										
Compressor: FLA/LRA Run Cap. MFD./Volts Acc. Start Kit	COPELAND 17.9 / 90.5 35/440 NAMA001SC	Gas Type	Nat	Input (MBTUH)	60	Output (MBTUH)	47	Gas Valve	HW	Regulation Type	Snap	Manifold Pressure	3.5	Orifices	44	Pilot Orifice Size	.018	Temp. Rise 0F	30–60	Ignition Type	IID	Fan Control (ON/OFF)	TIME	Limit Control (MAX)	150	Heat Anticipator	.58	230V – Dry Coil										
																												TAP	LOW	MED L	MED H	HIGH						
Service Driers: Liquid/Charge Suction	16 cu in / 11oz 30 sq in	Ref. Charge (R-22 Oz.)	77	Clearances See Installation Instructions						External Static Pressure Inches of W. C.					.10	–	–	–	–																			
															.20	1110	–	1270	1435																			
																																.30	1080	–	1220	1375		
																																.40	1045	–	1165	1310		
																																.50	1005	–	1100	1245		
																																.60	955	–	1045	1175		
																																.70	905	–	990	1105		
																																		.20	925	–	1095	1345
																																.30	905	–	1065	1295		
																																.40	880	–	1030	1240		
																																.50	850	–	990	1180		
																																.60	815	–	945	1115		
																																.70	780	–	895	1050		

Note: Optimum operating charge will produce 15° – 25° F suction line superheat at compressor with 82° F outdoor Ambient and 80° F, Dry Bulb (67° F, Wet Bulb) indoor temperature at rated airflow.

1065415-B
9-16-91
AH-3

Technical Service Data Sheets 1065416-B & 1065417-B

Model or Style No. PGAA36D1K		Performance Data: 80° D.B. Indoor																					
Specifications		Low Wet Bulb (63°)					High Wet Bulb (69°)																
Electrical:		Coil - Internal					Rated 1200 CFM ESP Wet.																
Voltage/Cycles/Phase Branch Circuit Ampacity Wire Size/Max. Ft. Time Delay Fuse Size Max. Fuse/HACR Brk. Boost Transformer		Amb. Outd	Appx. MBTUH	Sens. Total Ratio	PSIG. Disch. (Head)	PSIG. Suct.	Unit Amp.	Amb. Outd	Appx. MBTUH	Sens. Total Ratio	PSIG. Disch. (Head)	PSIG. Suct.	Unit Amp.										
208/230/60/1 27.4 No. 10 / 50' 35 45 - - - -		65	34.6	.87	178	65	13.6	65	37.9	.61	192	74	14.3										
Fan Motor:		75	33.9	.89	199	68	14.6	75	37.1	.63	214	78	15.3										
COND. EVAP.		85	33.3	.91	226	72	15.5	85	36.4	.65	244	82	16.3										
H.P./Type		95	32.4	.93	257	75	16.4	95	35.5	.66	277	86	17.3										
FLA/LRA		105	30.9	.94	289	78	17.4	105	33.8	.67	311	89	18.3										
Run Cap. MFD./Volts		115	28.3	.94	318	81	18.3	115	30.9	.67	344	93	19.3										
Acc. Start Kit		Heating External Static Pressure Inches of W. C.																					
Service Driers:													230V - Dry Coil					208V - Dry Coil					
Liquid/Charge													TAP	LOW	MED L	MED H	HIGH	TAP	LOW	MED L	MED H	HIGH	
Suction													.10	-	-	-	-	.10	-	-	-	-	
Ref. Charge (R-22 Oz.)													.20	1110	-	1270	1435	.20	925	-	1095	1345	
77													.30	1080	-	1220	1375	.30	905	-	1065	1295	
Clearances													.40	1045	-	1165	1310	.40	880	-	1030	1240	
See Installation Instructions													.50	1005	-	1100	1245	.50	850	-	990	1180	
Compressor:													.60	955	-	1045	1175	.60	815	-	945	1115	
FLA/LRA													.70	905	-	990	1105	.70	780	-	895	1050	
Run Cap. MFD./Volts													Note: Optimum operating charge will produce 15° - 25° F suction line superheat at compressor with 82° F outdoor Ambient and 80° F, Dry Bulb (67° F, Wet Bulb) indoor temperature at rated airflow.										
Acc. Start Kit													1065416-B 9-16-91 AH-3										

Model or Style No. PGAA36E1K		Performance Data: 80° D.B. Indoor																					
Specifications		Low Wet Bulb (63°)					High Wet Bulb (69°)																
Electrical:		Coil - Internal					Rated 1200 CFM ESP Wet.																
Voltage/Cycles/Phase Branch Circuit Ampacity Wire Size/Max. Ft. Time Delay Fuse Size Max. Fuse/HACR Brk. Boost Transformer		Amb. Outd	Appx. MBTUH	Sens. Total Ratio	PSIG. Disch. (Head)	PSIG. Suct.	Unit Amp.	Amb. Outd	Appx. MBTUH	Sens. Total Ratio	PSIG. Disch. (Head)	PSIG. Suct.	Unit Amp.										
208/230/60/1 29.4 No. 8 / 80' 35 45 - - - -		65	34.6	.87	178	65	14.2	65	37.9	.61	192	74	15.0										
Fan Motor:		75	33.9	.89	199	68	15.2	75	37.1	.63	214	78	16.1										
COND. EVAP.		85	33.3	.91	226	72	16.2	85	36.4	.65	244	82	17.1										
H.P./Type		95	32.4	.93	257	75	17.2	95	35.5	.66	277	86	18.1										
FLA/LRA		105	30.9	.94	289	78	18.2	105	33.8	.67	311	89	19.2										
Run Cap. MFD./Volts		115	28.3	.94	318	81	19.2	115	30.9	.67	344	93	20.2										
Acc. Start Kit		Heating External Static Pressure Inches of W. C.																					
Service Driers:													230V - Dry Coil					208V - Dry Coil					
Liquid/Charge													TAP	LOW	MED L	MED H	HIGH	TAP	LOW	MED L	MED H	HIGH	
Suction													.10	-	-	-	-	.10	-	-	-	-	
Ref. Charge (R-22 Oz.)													.20	1070	1295	1490	1645	.20	870	1090	1330	1585	
77													.30	1055	1270	1440	1580	.30	860	1080	1300	1530	
Clearances													.40	1040	1235	1385	1515	.40	850	1055	1260	1480	
See Installation Instructions													.50	1020	1195	1330	1450	.50	840	1030	1220	1425	
Compressor:													.60	990	1145	1270	1385	.60	825	1000	1170	1365	
FLA/LRA													.70	955	1095	1210	1315	.70	805	960	1120	1300	
Run Cap. MFD./Volts													Note: Optimum operating charge will produce 15° - 25° F suction line superheat at compressor with 82° F outdoor Ambient and 80° F, Dry Bulb (67° F, Wet Bulb) indoor temperature at rated airflow.										
Acc. Start Kit													1065417-B 9-16-91 AH-3										

Technical Service Data Sheets 1065418-B & 1065419-B

Model or Style No. PGAA42C1K		Performance Data: 80° D.B. Indoor											
Specifications		Low Wet Bulb (63°)					High Wet Bulb (69°)						
Electrical:		Coil – Internal					Rated 1400 CFM .20 ESP Wet.						
Voltage/Cycles/Phase Branch Circuit Ampacity Wire Size/Max. Ft. Time Delay Fuse Size Max. Fuse/HACR Brk. Boost Transformer	208/230/60/1 31.8 No. 8 / 70' 40 50 -----	Amb. Outd	Appx. MBTUH	Sens. Total Ratio	PSIG. Disch. (Head)	PSIG. Suct.	Unit Amp.	Amb. Outd	Appx. MBTUH	Sens. Total Ratio	PSIG. Disch. (Head)	PSIG. Suct.	Unit Amp.
Fan Motor:	COND. EVAP. H.P./Type 1/3 PSC 3/4 PSC FLA/LRA 1.4/13.57 5.6/12.8 Speeds/CFM 1/3000 4/1645 Cap. MFD/Volts 5/370 15/370	65	40.3	.87	188	64	17.2	65	44.1	.61	203	72	18.1
		75	39.4	.89	210	67	18.4	75	43.1	.63	227	76	19.4
		85	38.7	.91	239	70	19.6	85	42.4	.65	258	80	20.6
		95	37.7	.93	271	74	20.8	95	41.3	.66	293	84	21.9
		105	35.9	.94	305	77	21.9	105	39.3	.67	329	87	23.1
		115	32.9	.94	336	80	23.1	115	36.0	.67	363	91	24.3
Compressor:		Heating											
FLA/LRA Run Cap. MFD./Volts Acc. Start Kit	COPELAND 19.9 / 107 35/440 NAMA001SC	Gas Type		Nat		External Static Pressure							
Service Driers:	16 cu in / 11oz 30 sq in	Input (MBTUH)		60		Inches of W. C.							
Ref. Charge (R-22 Oz.)	82	Output (MBTUH)		47		230V – Dry Coil							
Clearances	See Installation Instructions	Gas Valve		HW		TAP	LOW	MED L	MED H	HIGH			
		Regulation Type		Snap		.10	–	–	–	–			
		Manifold Pressure		3.5		.20	1070	1295	1490	1645			
		Orifices		44		.30	1055	1270	1440	1580			
		Pilot Orifice Size		.018		.40	1040	1235	1385	1515			
		Temp. Rise 0F		30–60		.50	1020	1195	1330	1450			
		Ignition Type		IID		.60	990	1145	1270	1385			
		Fan Control (ON/OFF)		TIME		.70	955	1095	1210	1315			
		Limit Control (MAX)		160		208V – Dry Coil							
		Heat Anticipator		.58		TAP	LOW	MED L	MED H	HIGH			
						.10	–	–	–	–			
						.20	870	1090	1330	1585			
						.30	860	1080	1300	1530			
						.40	850	1055	1260	1480			
						.50	840	1030	1220	1425			
						.60	825	1000	1170	1365			
						.70	805	960	1120	1300			

Note: Optimum operating charge will produce 15° – 25° F suction line superheat at compressor with 82° F outdoor Ambient and 80° F, Dry Bulb (67° F, Wet Bulb) indoor temperature at rated airflow.

1065418-B
9-16-91
AH-3

Model or Style No. PGAA42E1K		Performance Data: 80° D.B. Indoor											
Specifications		Low Wet Bulb (63°)					High Wet Bulb (69°)						
Electrical:		Coil – Internal					Rated 1400 CFM .20 ESP Wet.						
Voltage/Cycles/Phase Branch Circuit Ampacity Wire Size/Max. Ft. Time Delay Fuse Size Max. Fuse/HACR Brk. Boost Transformer	208/230/60/1 31.8 No. 8 / 70' 40 50 -----	Amb. Outd	Appx. MBTUH	Sens. Total Ratio	PSIG. Disch. (Head)	PSIG. Suct.	Unit Amp.	Amb. Outd	Appx. MBTUH	Sens. Total Ratio	PSIG. Disch. (Head)	PSIG. Suct.	Unit Amp.
Fan Motor:	COND. EVAP. H.P./Type 1/3 PSC 3/4 PSC FLA/LRA 1.4/13.57 5.6/12.8 Speeds/CFM 1/3000 4/1645 Cap. MFD/Volts 5/370 15/370	65	40.3	.87	188	64	17.2	65	44.1	.61	203	72	18.1
		75	39.4	.89	210	67	18.4	75	43.1	.63	227	76	19.4
		85	38.7	.91	239	70	19.6	85	42.4	.65	258	80	20.6
		95	37.7	.93	271	74	20.8	95	41.3	.66	293	84	21.9
		105	35.9	.94	305	77	21.9	105	39.3	.67	329	87	23.1
		115	32.9	.94	336	80	23.1	115	36.0	.67	363	91	24.3
Compressor:		Heating											
FLA/LRA Run Cap. MFD./Volts Acc. Start Kit	COPELAND 19.9 / 107 35/440 NAMA001SC	Gas Type		Nat		External Static Pressure							
Service Driers:	16 cu in / 11oz 30 sq in	Input (MBTUH)		115/95		Inches of W. C.							
Ref. Charge (R-22 Oz.)	82	Output (MBTUH)		90/75		230V – Dry Coil							
Clearances	See Installation Instructions	Gas Valve		HW		TAP	LOW	MED L	MED H	HIGH			
		Regulation Type		Snap		.10	–	–	–	–			
		Manifold Pressure		3.5		.20	1070	1295	1490	1645			
		Orifices		43/46		.30	1055	1270	1440	1580			
		Pilot Orifice Size		.018		.40	1040	1235	1385	1515			
		Temp. Rise 0F		45–75		.50	1020	1195	1330	1450			
		Ignition Type		IID		.60	990	1145	1270	1385			
		Fan Control (ON/OFF)		TIME		.70	955	1095	1210	1315			
		Limit Control (MAX)		135		208V – Dry Coil							
		Heat Anticipator		.58		TAP	LOW	MED L	MED H	HIGH			
						.10	–	–	–	–			
						.20	870	1090	1330	1585			
						.30	860	1080	1300	1530			
						.40	850	1055	1260	1480			
						.50	840	1030	1220	1425			
						.60	825	1000	1170	1365			
						.70	805	960	1120	1300			

Note: Optimum operating charge will produce 15° – 25° F suction line superheat at compressor with 82° F outdoor Ambient and 80° F, Dry Bulb (67° F, Wet Bulb) indoor temperature at rated airflow.

1065419-B
9-16-91
AH-3

Technical Service Data Sheets 1065471-A & 1065543-A

Model or Style No. PGAA29D1K		Performance Data: 80° D.B. Indoor															
Specifications		Low Wet Bulb (63°)					High Wet Bulb (69°)										
Electrical: Voltage/Cycles/Phase Branch Circuit Ampacity Wire Size/Max. Ft. Time Delay Fuse Size Max. Fuse/HACR Brk. Boost Transformer 208/230/60/1 20.5 No. 10 / 60' 25 30 -	COND. EVAP. 1/3 PSC 1/3PSC 1.4/3.57 2.3/4.10 1/3000 3/1175 5/370 7.5/370	Coil - Internal						Rated 1000 CFM		.40 ESP Wet.							
		Amb. Outd	Appx. MBTUH	Sens. Total Ratio	PSIG. Disch. (Head)	PSIG. Suct.	Unit Amp.	Amb. Outd	Appx. MBTUH	Sens. Total Ratio	PSIG. Disch. (Head)	PSIG. Suct.	Unit Amp.				
		Fan Motor: H.P./Type FLA/LRA Speeds/CFM Cap. MFD/Volts		Compressor: FLA/LRA Run Cap. MFD./Volts Acc. Start Kit		Service Driers: Liquid/Charge Suction		Ref. Charge (R-22 Oz.) 74		Clearances See Installation Instructions		Heating			230V - Dry Coil		
		Compressor: COPELAND 13.5 / 76.0 35/370 NAMA001SC		Service Driers: 8 cu in / 7oz 30 sq in		Ref. Charge (R-22 Oz.) 74		Clearances See Installation Instructions		Heating			230V - Dry Coil				
		Compressor: COPELAND 23.7 / 129 40 / 440 NAMA001SC		Service Driers: 30 cu in / 17oz 30 sq in		Ref. Charge (R-22 Oz.) 124		Clearances See Installation Instructions		Heating			230V - Dry Coil				
		Compressor: COPELAND 23.7 / 129 40 / 440 NAMA001SC		Service Driers: 30 cu in / 17oz 30 sq in		Ref. Charge (R-22 Oz.) 124		Clearances See Installation Instructions		Heating			230V - Dry Coil				

Note: Optimum operating charge will produce 15° - 25° F suction line superheat at compressor with 82° F outdoor Ambient and 80° F, Dry Bulb (67° F, Wet Bulb) indoor temperature at rated airflow.

1065471-A
7-22-91
AH-2

Model or Style No. PGAA48D1K		Performance Data: 80° D.B. Indoor															
Specifications		Low Wet Bulb (63°)					High Wet Bulb (69°)										
Electrical: Voltage/Cycles/Phase Branch Circuit Ampacity Wire Size/Max. Ft. Time Delay Fuse Size Max. Fuse/HACR Brk. Boost Transformer 208/230/60/1 36.6 No. 6 / 90' 45 60 - - -	COND. EVAP. 3 / 4 PSC 1 / 2 PSC 2.6 / 9.52 4.4 / 8.63 1 / 4500 4 / 1860 10 / 440 15 / 370	Coil - Internal						Rated 1600 CFM		.20 ESP Wet.							
		Amb. Outd	Appx. MBTUH	Sens. Total Ratio	PSIG. Disch. (Head)	PSIG. Suct.	Unit Amp.	Amb. Outd	Appx. MBTUH	Sens. Total Ratio	PSIG. Disch. (Head)	PSIG. Suct.	Unit Amp.				
		Fan Motor: H.P./Type FLA/LRA Speeds/CFM Cap. MFD/Volts		Compressor: COPELAND 23.7 / 129 40 / 440 NAMA001SC		Service Driers: 30 cu in / 17oz 30 sq in		Ref. Charge (R-22 Oz.) 124		Clearances See Installation Instructions		Heating			230V - Dry Coil		
		Fan Motor: H.P./Type FLA/LRA Speeds/CFM Cap. MFD/Volts		Compressor: COPELAND 23.7 / 129 40 / 440 NAMA001SC		Service Driers: 30 cu in / 17oz 30 sq in		Ref. Charge (R-22 Oz.) 124		Clearances See Installation Instructions		Heating			230V - Dry Coil		
		Fan Motor: H.P./Type FLA/LRA Speeds/CFM Cap. MFD/Volts		Compressor: COPELAND 23.7 / 129 40 / 440 NAMA001SC		Service Driers: 30 cu in / 17oz 30 sq in		Ref. Charge (R-22 Oz.) 124		Clearances See Installation Instructions		Heating			230V - Dry Coil		
		Fan Motor: H.P./Type FLA/LRA Speeds/CFM Cap. MFD/Volts		Compressor: COPELAND 23.7 / 129 40 / 440 NAMA001SC		Service Driers: 30 cu in / 17oz 30 sq in		Ref. Charge (R-22 Oz.) 124		Clearances See Installation Instructions		Heating			230V - Dry Coil		

Note: Optimum operating charge will produce 15° - 25° F suction line superheat at compressor with 82° F outdoor Ambient and 80° F, Dry Bulb (67° F, Wet Bulb) indoor temperature at rated airflow.

1065543-A
8-21-91
AH-3

Technical Service Data Sheets 1065551-A & 1065559-A

Model or Style No. PGAA48F1K		Performance Data: 80° D.B. Indoor											
Specifications		Low Wet Bulb (63°)					High Wet Bulb (69°)						
		Coil – Internal					Rated 1600 CFM .30 ESP Wet.						
		Amb. Outd	Appx. MBTUH	Sens. Total Ratio	PSIG. Disch. (Head)	PSIG. Suct.	Unit Amp.	Amb. Outd	Appx. MBTUH	Sens. Total Ratio	PSIG. Disch. (Head)	PSIG. Suct.	Unit Amp.
Electrical: Voltage/Cycles/Phase Branch Circuit Ampacity Wire Size/Max. Ft. Time Delay Fuse Size Max. Fuse/HACR Brk. Boost Transformer	208/230/60/1 36.8 No. 6 / 90' 45 60 - - - -	65	48.3	0.86	183	61	20.2	65	52.9	0.60	198	70	21.3
		75	47.3	0.88	205	64	21.6	75	51.7	0.62	221	74	22.8
		85	45.6	0.90	233	68	23.0	85	50.8	0.64	251	77	24.3
		95	45.3	0.92	265	71	24.4	95	49.5	0.65	286	81	25.8
		105	43.1	0.93	297	74	25.8	105	47.2	0.66	321	84	27.2
Fan Motor: H.P./Type FLA/LRA Speeds/CFM Cap. MFD/Volts	COND. EVAP. 3 / 4 PSC 1 PSC 2.6 / 9.52 4.6 / 7.94 1 / 4500 3 / 2185 10 / 440 20 / 370	Heating											
Compressor: FLA/LRA Run Cap. MFD./Volts Acc. Start Kit	COPELAND 23.7 / 129 40 / 440 NAMA001SC	Gas Type	Nat										
		Input (MBTUH)	135 / 110										
Service Driers: Liquid/Charge Suction	30 cu in / 17oz 30 sq in	Output (MBTUH)	106 / 87										
		Gas Valve	HW										
		Regulation Type	Snap										
		Manifold Pressure	3.5										
Ref. Charge (R-22 Oz.)	124	Orifices	43/46										
		Pilot Orifice Size	.018										
Clearances See Installation Instructions		Temp. Rise 0F	35-65										
		Ignition Type	IID										
		Fan Control (ON/OFF)	TIME										
		Limit Control (MAX)	135										
		Heat Anticipator	.58										
		Heating											
							230V – Dry Coil						
							External Static Pressure						
							Inches of W. C.						
							TAP	LOW	MED L	MED H	HIGH		
							.10	1700	----	1830	2260		
							.20	1685	----	1805	2185		
							.30	1660	----	1775	2125		
							.40	1625	----	1735	2065		
							.50	1585	----	1690	2010		
							.60	1540	----	1635	1950		
							.70	1485	----	1580	1875		
							208V – Dry Coil						
							TAP	LOW	MED L	MED H	HIGH		
							.10	1445	----	1560	2025		
							.20	1430	----	1545	1995		
							.30	1415	----	1530	1960		
							.40	1390	----	1505	1915		
							.50	1355	----	1475	1870		
							.60	1320	----	1435	1810		
							.70	1275	----	1390	1745		
Note: Optimum operating charge will produce 15° – 25° F suction line superheat at compressor with 82° F outdoor Ambient and 80° F, Dry Bulb (67° F, Wet Bulb) indoor temperature at rated airflow.											1065551-A 8-21-91 AH-3		

Model or Style No. PGAA60D1K		Performance Data: 80° D.B. Indoor											
Specifications		Low Wet Bulb (63°)					High Wet Bulb (69°)						
		Coil – Internal					Rated 2000 CFM .30 ESP Wet.						
		Amb. Outd	Appx. MBTUH	Sens. Total Ratio	PSIG. Disch. (Head)	PSIG. Suct.	Unit Amp.	Amb. Outd	Appx. MBTUH	Sens. Total Ratio	PSIG. Disch. (Head)	PSIG. Suct.	Unit Amp.
Electrical: Voltage/Cycles/Phase Branch Circuit Ampacity Wire Size/Max. Ft. Time Delay Fuse Size Max. Fuse/HACR Brk. Boost Transformer	208/230/60/1 43.7 No. 6 / 70' 60 60 - - - -	65	59.9	0.86	197	63	25.2	65	65.5	0.60	213	72	26.5
		75	58.6	0.88	221	67	27.0	75	64.1	0.62	238	76	28.4
		85	57.6	0.90	251	70	28.7	85	63.0	0.64	271	80	30.3
		95	56.1	0.92	285	73	30.5	95	61.4	0.65	308	84	32.1
		105	53.5	0.93	321	76	32.2	105	58.5	0.66	346	87	33.9
Fan Motor: H.P./Type FLA/LRA Speeds/CFM Cap. MFD/Volts	COND. EVAP. 3 / 4 PSC 1 PSC 2.6 / 9.52 5.0 / 8.75 1 / 4500 4 / 2250 10 / 440 20 / 370	Heating											
Compressor: FLA/LRA Run Cap. MFD./Volts Acc. Start Kit	COPELAND 28.8 / 169 55/440 NAMA001SC	Gas Type	Nat										
		Input (MBTUH)	90 / 75										
Service Driers: Liquid/Charge Suction	30 cu in / 17oz 30 sq in	Output (MBTUH)	71 / 59										
		Gas Valve	HW										
		Regulation Type	Snap										
		Manifold Pressure	3.5										
Ref. Charge (R-22 Oz.)	122	Orifices	43/46										
		Pilot Orifice Size	.018										
Clearances See Installation Instructions		Temp. Rise 0F	33 / 60										
		Ignition Type	IID										
		Fan Control (ON/OFF)	TIME										
		Limit Control (MAX)	135										
		Heat Anticipator	.58										
		Heating											
							230V – Dry Coil						
							External Static Pressure						
							Inches of W. C.						
							TAP	LOW	MED L	MED H	HIGH		
							.10	1330	1670	2130	2300		
							.20	1315	1650	2090	2250		
							.30	1300	1630	2045	2190		
							.40	1280	1600	1995	2125		
							.50	1255	1565	1935	2060		
							.60	1225	1525	1875	1990		
							.70	1185	1475	1805	1915		
							208V – Dry Coil						
							TAP	LOW	MED L	MED H	HIGH		
							.10	1110	1405	1880	2110		
							.20	1100	1390	1855	2065		
							.30	1080	1375	1825	2020		
							.40	1060	1355	1790	1975		
							.50	1035	1330	1750	1925		
							.60	1000	1295	1695	1860		
							.70	950	1250	1635	1790		
Note: Optimum operating charge will produce 15° – 25° F suction line superheat at compressor with 82° F outdoor Ambient and 80° F, Dry Bulb (67° F, Wet Bulb) indoor temperature at rated airflow.											1065559-A 8-21-91 AH-3		

Technical Service Data Sheets 1065567-A & 1065575-A

Model or Style No. PGAA60E1K		Performance Data: 80° D.B. Indoor																
Specifications		Low Wet Bulb (63°)					High Wet Bulb (69°)											
		Coil - Internal					Rated 2000 CFM .30 ESP Wet.											
		Amb. Outd	Appx. MBTUH	Sens. Total Ratio	PSIG. Disch. (Head)	PSIG. Suct.	Unit Amp.	Amb. Outd	Appx. MBTUH	Sens. Total Ratio	PSIG. Disch. (Head)	PSIG. Suct.	Unit Amp.					
Electrical: Voltage/Cycles/Phase Branch Circuit Ampacity Wire Size/Max. Ft. Time Delay Fuse Size Max. Fuse/HACR Brk. Boost Transformer	208/230/60/1	65	59.9	0.86	197	63	25.2	65	65.5	0.60	213	72	26.5					
	43.7	75	58.6	0.88	221	67	27.0	75	64.1	0.62	238	76	28.4					
	No. 6 / 70'	85	57.6	0.90	251	70	28.7	85	63.0	0.64	271	80	30.3					
	60	95	56.1	0.92	285	73	30.5	95	61.4	0.65	308	84	32.1					
	60	105	53.5	0.93	321	76	32.2	105	58.5	0.66	346	87	33.9					
Fan Motor: H.P./Type FLA/LRA Speeds/CFM Cap. MFD/Volts	COND.	115	48.9	0.93	354	79	33.9	115	53.5	0.66	382	90	35.7					
	EVAP.																	
Compressor: FLA/LRA Run Cap. MFD./Volts Acc. Start Kit	COPELAND	Heating																
	28.8 / 169 55/440 NAMA001SC																	
Service Driers: Liquid/Charge Suction	30 cu in / 17oz 30 sq in	Gas Type	Nat															
		Input (MBTUH)	115 / 95															
Ref. Charge (R-22 Oz.)	122	Output (MBTUH)	91 / 75															
		Gas Valve	HW															
Clearances See Installation Instructions		Regulation Type	Snap															
		Manifold Pressure	3.5															
External Static Pressure Inches of W. C.		Orifices	43/46															
			Pilot Orifice Size	.018														
				Temp. Rise 0F	30-60													
					Ignition Type	IID												
						Fan Control (ON/OFF)	TIME											
							Limit Control (MAX)	135										
								Heat Anticipator	.58									
									230V - Dry Coil									
									TAP	LOW	MED L	MED H	HIGH					
									.10	1330	1670	2130	2300					
.20	1315	1650							2090	2250								
.30	1300	1630	2045						2190									
.40	1280	1600	1995	2125														
.50	1255	1565	1935	2060														
.60	1225	1525	1875	1990														
.70	1185	1475	1805	1915														
208V - Dry Coil																		
TAP	LOW	MED L	MED H	HIGH														
.10	1110	1405	1880	2110														
.20	1100	1390	1855	2065														
.30	1080	1375	1825	2020														
.40	1060	1355	1790	1975														
.50	1035	1330	1750	1925														
.60	1000	1295	1695	1860														
.70	950	1250	1635	1790														

Note: Optimum operating charge will produce 15° - 25° F suction line superheat at compressor with 82° F outdoor Ambient and 80° F, Dry Bulb (67° F, Wet Bulb) indoor temperature at rated airflow.

1065567-A
8-21-91
AH-3

Model or Style No. PGAA60G1K		Performance Data: 80° D.B. Indoor																
Specifications		Low Wet Bulb (63°)					High Wet Bulb (69°)											
		Coil - Internal					Rated 2000 CFM .30 ESP Wet.											
		Amb. Outd	Appx. MBTUH	Sens. Total Ratio	PSIG. Disch. (Head)	PSIG. Suct.	Unit Amp.	Amb. Outd	Appx. MBTUH	Sens. Total Ratio	PSIG. Disch. (Head)	PSIG. Suct.	Unit Amp.					
Electrical: Voltage/Cycles/Phase Branch Circuit Ampacity Wire Size/Max. Ft. Time Delay Fuse Size Max. Fuse/HACR Brk. Boost Transformer	208/230/60/1	65	59.9	0.86	197	63	25.2	65	65.5	0.60	213	72	26.5					
	44.7	75	58.6	0.88	221	67	27.0	75	64.1	0.62	238	76	28.4					
	No. 6 / 70'	85	57.6	0.90	251	70	28.7	85	63.0	0.64	271	80	30.3					
	60	95	56.1	0.92	285	73	30.5	95	61.4	0.65	308	84	32.1					
	60	105	53.5	0.93	321	76	32.2	105	58.5	0.66	346	87	33.9					
Fan Motor: H.P./Type FLA/LRA Speeds/CFM Cap. MFD/Volts	COND.	115	48.9	0.93	354	79	33.9	115	53.5	0.66	382	90	35.7					
	EVAP.																	
Compressor: FLA/LRA Run Cap. MFD./Volts Acc. Start Kit	COPELAND	Heating																
	28.8 / 169 55 / 440 NAMA001SC																	
Service Driers: Liquid/Charge Suction	30 cu in / 17oz 30 sq in	Gas Type	Nat															
		Input (MBTUH)	150/130															
Ref. Charge (R-22 Oz.)	122	Output (MBTUH)	119 / 102															
		Gas Valve	HW															
Clearances See Installation Instructions		Regulation Type	Snap															
		Manifold Pressure	3.5															
External Static Pressure Inches of W. C.		Orifices	43/46															
			Pilot Orifice Size	.018														
				Temp. Rise 0F	35-65													
					Ignition Type	IID												
						Fan Control (ON/OFF)	TIME											
							Limit Control (MAX)	130										
								Heat Anticipator	.58									
									230V - Dry Coil									
									TAP	LOW	MED L	MED H	HIGH					
									.10	2140	2260	2395	2470					
.20	2095	2205							2335	2400								
.30	2040	2145	2270						2325									
.40	1985	2080	2200	2250														
.50	1920	2015	2125	2170														
.60	1855	1940	2050	2085														
.70	1780	1865	1965	2000														
208V - Dry Coil																		
TAP	LOW	MED L	MED H	HIGH														
.10	1915	2090	2310	2380														
.20	1885	2045	2250	2315														
.30	1845	1995	2185	2250														
.40	1805	1945	2125	2185														
.50	1755	1890	2060	2105														
.60	1700	1820	1980	2020														
.70	1640	1750	1905	1940														

Note: Optimum operating charge will produce 15° - 25° F suction line superheat at compressor with 82° F outdoor Ambient and 80° F, Dry Bulb (67° F, Wet Bulb) indoor temperature at rated airflow.

1065575-A
8-21-91
AH-3

Technical Service Data Sheets 1065848-A & 1065849-A

Model or Style No. PGAB24B1K		Performance Data: 80° D.B. Indoor											
Specifications		Low Wet Bulb (63°)						High Wet Bulb (69°)					
		Coil – Internal					Rated 800 CFM .15 ESP Wet.						
		Ambient Outdoor 5F	Approx. MBTUH	Sens. Total Ratio	PSIG. Liquid (Head)	PSIG. Suct.	Unit Amps	Ambient Outdoor 5F	Approx. MBTUH	Sens. Total Ratio	PSIG. Liquid (Head)	PSIG. Suct.	Unit Amps
Electrical: Voltage/Cycles/Phase Branch Circuit Ampacity Wire Size/Max. Ft. Time Delay Fuse Size Max. Fuse/HACR Brk. Boost Transformer	208/230/60/1 17.3 No. 14 / 30' 25 25 - - - -	65	24.2	0.86	175	67	8.8	65	26.4	0.60	189	76	9.3
		75	23.6	0.88	195	71	9.4	75	25.9	0.62	211	80	9.9
		85	23.2	0.90	222	74	10.1	85	25.4	0.64	240	84	10.6
		95	22.6	0.92	253	77	10.7	95	24.8	0.65	273	88	11.2
		105	21.6	0.93	284	81	11.3	105	23.6	0.66	306	92	11.9
		115	19.7	0.93	313	84	11.9	115	21.6	0.66	338	95	12.5
Fan Motor: H.P./Type FLA/LRA Speeds/CFM Cap. MFD/Volts	COND. EVAP. 1/6 PSC 1/4PSC .8/1.72 2.1/3.08 1/2250 4/995 5/370 5/370	Heating											
Compressor: FLA/LRA Run Cap. MFD./Volts Acc. Start Kit	COPELAND 11.5 / 62.5 30/370 NAMA001SC	Gas Type Input (MBTUH) Output (MBTUH) Gas Valve Regulation Type Manifold Pressure Orifices Pilot Orifice Size	Nat 40 31 HW Snap 3.5 44 .018	External Static Pressure Inches of W. C.	230V – Dry Coil TAP LOW MED L MED H HIGH .10 – – – – .20 620 725 825 995 .30 605 705 805 960 .40 585 675 775 925 .50 565 650 745 880 .60 530 615 705 835 .70 485 570 660 780								
					208V – Dry Coil TAP LOW MED L MED H HIGH .10 – – – – .20 535 620 725 890 .30 520 600 700 860 .40 500 580 670 830 .50 475 550 635 790 .60 435 515 600 750 .70 385 470 555 705								
Service Driers: Liquid/Charge Suction	8 cu in / 7oz 30 sq in	Ref. Charge (R-22 Oz.) 80	Temp. Rise ° F Ignition Type Fan Control (ON/OFF) Limit Control (MAX) Heat Anticipator	30–60 IID TIME 160 .58									
Clearances See Installation Instructions													
Note: Optimum operating charge will produce 15° – 25° F suction line superheat at compressor with 82° F outdoor ambient and 80° F, Dry Bulb (67° F, Wet Bulb) indoor temperature at rated airflow.												1065848-A 3–6–92 AH-1	

Model or Style No. PGAB24C1K		Performance Data: 80° D.B. Indoor											
Specifications		Low Wet Bulb (63°)						High Wet Bulb (69°)					
		Coil – Internal					Rated 800 CFM .15 ESP Wet.						
		Ambient Outdoor 5F	Approx. MBTUH	Sens. Total Ratio	PSIG. Liquid (Head)	PSIG. Suct.	Unit Amps	Ambient Outdoor 5F	Approx. MBTUH	Sens. Total Ratio	PSIG. Liquid (Head)	PSIG. Suct.	Unit Amps
Electrical: Voltage/Cycles/Phase Branch Circuit Ampacity Wire Size/Max. Ft. Time Delay Fuse Size Max. Fuse/HACR Brk. Boost Transformer	208/230/60/1 17.3 No. 14 / 30' 25 25 - - - -	65	24.2	0.86	175	67	8.8	65	26.4	0.60	189	76	9.3
		75	23.6	0.88	195	71	9.4	75	25.9	0.62	211	80	9.9
		85	23.2	0.90	222	74	10.1	85	25.4	0.64	240	84	10.6
		95	22.6	0.92	253	77	10.7	95	24.8	0.65	273	88	11.2
		105	21.6	0.93	284	81	11.3	105	23.6	0.66	306	92	11.9
		115	19.7	0.93	313	84	11.9	115	21.6	0.66	338	95	12.5
Fan Motor: H.P./Type FLA/LRA Speeds/CFM Cap. MFD/Volts	COND. EVAP. 1/6 PSC 1/4PSC .8/1.72 2.1/3.08 1/2250 4/995 5/370 5/370	Heating											
Compressor: FLA/LRA Run Cap. MFD./Volts Acc. Start Kit	COPELAND 11.5 / 62.5 30/370 NAMA001SC	Gas Type Input (MBTUH) Output (MBTUH) Gas Valve Regulation Type Manifold Pressure Orifices Pilot Orifice Size	Nat 60 47 HW Snap 3.5 44 .018	External Static Pressure Inches of W. C.	230V – Dry Coil TAP LOW MED L MED H HIGH .10 – – – – .20 620 725 825 995 .30 605 705 805 960 .40 585 675 775 925 .50 565 650 745 880 .60 530 615 705 835 .70 485 570 660 780								
					208V – Dry Coil TAP LOW MED L MED H HIGH .10 – – – – .20 535 620 725 890 .30 520 600 700 860 .40 500 580 670 830 .50 475 550 635 790 .60 435 515 600 750 .70 385 470 555 705								
Service Driers: Liquid/Charge Suction	8 cu in / 7oz 30 sq in	Ref. Charge (R-22 Oz.) 80	Temp. Rise ° F Ignition Type Fan Control (ON/OFF) Limit Control (MAX) Heat Anticipator	45–75 IID TIME 150 .58									
Clearances See Installation Instructions													
Note: Optimum operating charge will produce 15° – 25° F suction line superheat at compressor with 82° F outdoor ambient and 80° F, Dry Bulb (67° F, Wet Bulb) indoor temperature at rated airflow.												1065849-A 3–6–92 AH-1	

Technical Service Data Sheets 1065850-A & 1065956

Model or Style No. PGAB24D1K		Performance Data: 80° D.B. Indoor													
Specifications		Low Wet Bulb (63°)						High Wet Bulb (69°)							
		Coil - Internal						Rated 800 CFM .15 ESP Wet.							
		Ambient Outdoor 5F	Approx. MBTUH	Sens. Total Ratio	PSIG. Liquid (Head)	PSIG. Suct.	Unit Amps	Ambient Outdoor 5F	Approx. MBTUH	Sens. Total Ratio	PSIG. Liquid (Head)	PSIG. Suct.	Unit Amps		
Electrical: Voltage/Cycles/Phase Branch Circuit Ampacity Wire Size/Max. Ft. Time Delay Fuse Size Max. Fuse/HACR Brk. Boost Transformer	208/230/60/1 17.5 No. 14 / 30' 25 25 ---	65	24.2	0.86	175	67	8.8	65	26.4	0.60	189	76	9.3		
		75	23.6	0.88	195	71	9.4	75	25.9	0.62	211	80	9.9		
		85	23.2	0.90	222	74	10.1	85	25.4	0.64	240	84	10.6		
		95	22.6	0.92	253	77	10.7	95	24.8	0.65	273	88	11.2		
		105	21.6	0.93	284	81	11.3	105	23.6	0.66	306	92	11.9		
115	19.7	0.93	313	84	11.9	115	21.6	0.66	338	95	12.5				
Fan Motor: H.P./Type FLA/LRA Speeds/CFM Cap. MFD/Volts	COND. EVAP. 1/6 PSC 1/3 PSC 0.8 / 1.72 2.3 / 4.1 1 / 2250 3 / 1175 5 / 370 7.5 / 370	Heating													
Compressor: FLA/LRA Run Cap. MFD./Volts Acc. Start Kit	COPELAND 11.5 / 62.5 30/370 NAMA001SC	Gas Type		Nat		External Static Pressure Inches of W. C.									
		Input (MBTUH)		90 / 75											
Output (MBTUH)		70 / 59													
Gas Valve		HW													
Regulation Type		Snap													
Manifold Pressure		3.5													
Orifices		43 / 46													
Pilot Orifice Size		.018													
Temp. Rise ° F		45 / 75													
Ignition Type		IID													
Fan Control (ON/OFF)		TIME													
Limit Control (MAX)		135													
Heat Anticipator		.58													
Service Driers: Liquid/Charge Suction		8 cu in / 7oz 30 sq in													
Ref. Charge (R-22 Oz.)		80													
Clearances See Installation Instructions															
		230V - Dry Coil						208V - Dry Coil							
		TAP		LOW		MED L		MED H		HIGH					
		.10		-		-		-		-					
		.20		790		-		955		1175					
		.30		760		-		915		1120					
		.40		730		-		870		1055					
		.50		690		-		815		990					
		.60		645		-		755		920					
		.70		585		-		685		840					
		TAP		LOW		MED L		MED H		HIGH					
		.10		-		-		-		-					
		.20		670		-		825		1090					
		.30		645		-		790		1040					
		.40		620		-		750		985					
		.50		585		-		705		925					
		.60		540		-		650		855					
		.70		485		-		580		780					
Note: Optimum operating charge will produce 15° - 25° F suction line superheat at compressor with 82° F outdoor ambient and 80° F, Dry Bulb (67° F, Wet Bulb) indoor temperature at rated airflow.												1065850-A 3-6-92 AH-1			

Model or Style No. PGAB36C1K		Performance Data: 80° D.B. Indoor													
Specifications		Low Wet Bulb (63°)						High Wet Bulb (69°)							
		Coil - Internal						Rated 1200 CFM .20 ESP Wet.							
		Amb. Outd	Appx. MBTUH	Sens. Total Ratio	PSIG. Disch. (Head)	PSIG. Suct.	Unit Amp.	Amb. Outd	Appx. MBTUH	Sens. Total Ratio	PSIG. Disch. (Head)	PSIG. Suct.	Unit Amp.		
Electrical: Voltage/Cycles/Phase Branch Circuit Ampacity Wire Size/Max. Ft. Time Delay Fuse Size Max. Fuse/HACR Brk. Boost Transformer	208/230/60/1 27.4 No. 10 / 50' 35 45 ---	65	34.7	0.87	180	66	13.8	65	38.0	0.61	194	75	14.5		
		75	34.0	0.89	201	70	14.7	75	37.2	0.63	217	79	15.5		
		85	33.4	0.91	229	73	15.7	85	36.5	0.65	247	83	16.5		
		95	32.5	0.93	260	77	16.6	95	35.6	0.66	281	87	17.5		
		105	31.0	0.94	292	80	17.6	105	33.9	0.67	315	91	18.5		
115	28.4	0.94	323	83	18.5	115	31.0	0.67	348	94	19.5				
Fan Motor: H.P./Type FLA/LRA Speeds/CFM Cap. MFD/Volts	COND. EVAP. 1/3 PSC 1/2 PSC 1.4/13.57 3.6 / 7.5 1/3000 3 / 1435 5/370 15/370	Heating													
Compressor: FLA/LRA Run Cap. MFD./Volts Acc. Start Kit	COPELAND 17.9 / 90.5 35/440 NAMA001SC	Gas Type		Nat		External Static Pressure Inches of W. C.									
		Input (MBTUH)		60											
Output (MBTUH)		47													
Gas Valve		HW													
Regulation Type		Snap													
Manifold Pressure		3.5													
Orifices		44													
Pilot Orifice Size		.018													
Temp. Rise ° F		30 - 60													
Ignition Type		IID													
Fan Control (ON/OFF)		TIME													
Limit Control (MAX)		150													
Heat Anticipator		.58													
Service Driers: Liquid/Charge Suction		16 cu in / 11 oz 30 sq in													
Ref. Charge (R-22 Oz.)		80													
Clearances See Installation Instructions															
		230V - Dry Coil						208V - Dry Coil							
		TAP		LOW		MED L		MED H		HIGH					
		.10		-		-		-		-					
		.20		1110		-		1270		1435					
		.30		1080		-		1220		1375					
		.40		1045		-		1165		1310					
		.50		1005		-		1100		1245					
		.60		955		-		1045		1175					
		.70		905		-		990		1105					
		TAP		LOW		MED L		MED H		HIGH					
		.10		-		-		-		-					
		.20		925		-		1095		1345					
		.30		905		-		1065		1295					
		.40		880		-		1030		1245					
		.50		850		-		990		1180					
		.60		815		-		945		1115					
		.70		780		-		895		1050					
Note: Optimum operating charge will produce 15° - 25° F suction line superheat at compressor with 82° F outdoor ambient and 80° F, Dry Bulb (67° F, Wet Bulb) indoor temperature at rated airflow.												1065956 3-6-92 AH-1			

Technical Service Data Sheets 1065957 & 1065958

Model or Style No. PGAB36D1K		Performance Data: 80° D.B. Indoor																																																																																																																																																												
Specifications		Low Wet Bulb (63°)					High Wet Bulb (69°)																																																																																																																																																							
		Coil - Internal					Rated 1200 CFM			.20 ESP Wet.																																																																																																																																																				
		Ambient Outdoor 5F	Approx. MBTUH	Sens. Total Ratio	PSIG. Liquid (Head)	PSIG. Suct.	Unit Amps	Ambient Outdoor 5F	Approx. MBTUH	Sens. Total Ratio	PSIG. Liquid (Head)	PSIG. Suct.	Unit Amps																																																																																																																																																	
Electrical: Voltage/Cycles/Phase Branch Circuit Ampacity Wire Size/Max. Ft. Time Delay Fuse Size Max. Fuse/HACR Brk. Boost Transformer	208/230/60/1 27.4 No. 10 / 50' 35 45 ---	65	34.7	0.87	180	66	13.8	65	38.0	0.61	194	75	14.5																																																																																																																																																	
		75	34.0	0.89	201	70	14.7	75	37.2	0.63	217	79	15.5																																																																																																																																																	
		85	33.4	0.91	229	73	15.7	85	36.5	0.65	247	83	16.5																																																																																																																																																	
		95	32.5	0.93	260	77	16.6	95	35.6	0.66	281	87	17.5																																																																																																																																																	
		105	31.0	0.94	292	80	17.6	105	33.9	0.67	315	91	18.5																																																																																																																																																	
		115	28.4	0.94	323	83	18.5	115	31.0	0.67	348	94	19.5																																																																																																																																																	
Fan Motor: H.P./Type FLA/LRA Speeds/CFM Cap. MFD/Volts	COND. EVAP. 1/3 PSC 1 / 2 PSC 1.4/13.57 3.6 / 7.5 1/3000 3 / 1435 5/370 15/370	<table border="1"> <thead> <tr> <th colspan="11">Heating</th> </tr> <tr> <th colspan="2">Gas Type</th> <th colspan="9">230V - Dry Coil</th> </tr> <tr> <th>Input (MBTUH)</th> <th>Output (MBTUH)</th> <th>TAP</th> <th>LOW</th> <th>MED L</th> <th>MED H</th> <th>HIGH</th> <th colspan="5" rowspan="8"> External Static Pressure Inches of W. C. </th> </tr> </thead> <tbody> <tr> <td>90 / 75</td> <td>70 / 59</td> <td>.10</td><td>-</td><td>-</td><td>-</td><td>-</td> </tr> <tr> <td></td><td></td> <td>.20</td><td>1110</td><td>-</td><td>1270</td><td>1435</td> </tr> <tr> <td></td><td></td> <td>.30</td><td>1080</td><td>-</td><td>1220</td><td>1375</td> </tr> <tr> <td></td><td></td> <td>.40</td><td>1045</td><td>-</td><td>1165</td><td>1310</td> </tr> <tr> <td></td><td></td> <td>.50</td><td>1005</td><td>-</td><td>1100</td><td>1245</td> </tr> <tr> <td></td><td></td> <td>.60</td><td>955</td><td>-</td><td>1045</td><td>1175</td> </tr> <tr> <td></td><td></td> <td>.70</td><td>905</td><td>-</td><td>990</td><td>1105</td> </tr> <tr> <th colspan="2">Orifices</th> <th colspan="5">208V - Dry Coil</th> </tr> <tr> <td>43/46</td> <td></td> <th>TAP</th> <th>LOW</th> <th>MED L</th> <th>MED H</th> <th>HIGH</th> </tr> <tr> <td>Pilot Orifice Size</td> <td></td> <td>.10</td><td>-</td><td>-</td><td>-</td><td>-</td> </tr> <tr> <td>Temp. Rise 0F</td> <td>45 - 75</td> <td>.20</td><td>925</td><td>-</td><td>1095</td><td>1345</td> </tr> <tr> <td>Ignition Type</td> <td>IID</td> <td>.30</td><td>905</td><td>-</td><td>1065</td><td>1295</td> </tr> <tr> <td>Fan Control (ON/OFF)</td> <td>TIME</td> <td>.40</td><td>880</td><td>-</td><td>1030</td><td>1240</td> </tr> <tr> <td>Limit Control (MAX)</td> <td>135</td> <td>.50</td><td>850</td><td>-</td><td>990</td><td>1180</td> </tr> <tr> <td>Heat Anticipator</td> <td>.58</td> <td>.60</td><td>815</td><td>-</td><td>945</td><td>1115</td> </tr> <tr> <td></td><td></td> <td>.70</td><td>780</td><td>-</td><td>895</td><td>1050</td> </tr> </tbody> </table>											Heating											Gas Type		230V - Dry Coil									Input (MBTUH)	Output (MBTUH)	TAP	LOW	MED L	MED H	HIGH	External Static Pressure Inches of W. C.					90 / 75	70 / 59	.10	-	-	-	-			.20	1110	-	1270	1435			.30	1080	-	1220	1375			.40	1045	-	1165	1310			.50	1005	-	1100	1245			.60	955	-	1045	1175			.70	905	-	990	1105	Orifices		208V - Dry Coil					43/46		TAP	LOW	MED L	MED H	HIGH	Pilot Orifice Size		.10	-	-	-	-	Temp. Rise 0F	45 - 75	.20	925	-	1095	1345	Ignition Type	IID	.30	905	-	1065	1295	Fan Control (ON/OFF)	TIME	.40	880	-	1030	1240	Limit Control (MAX)	135	.50	850	-	990	1180	Heat Anticipator	.58	.60	815	-	945	1115			.70	780	-	895	1050
Heating																																																																																																																																																														
Gas Type													230V - Dry Coil																																																																																																																																																	
Input (MBTUH)	Output (MBTUH)												TAP	LOW	MED L	MED H	HIGH	External Static Pressure Inches of W. C.																																																																																																																																												
90 / 75	70 / 59												.10	-	-	-	-																																																																																																																																													
													.20	1110	-	1270	1435																																																																																																																																													
													.30	1080	-	1220	1375																																																																																																																																													
													.40	1045	-	1165	1310																																																																																																																																													
													.50	1005	-	1100	1245																																																																																																																																													
													.60	955	-	1045	1175																																																																																																																																													
		.70	905	-	990	1105																																																																																																																																																								
Orifices		208V - Dry Coil																																																																																																																																																												
43/46		TAP	LOW	MED L	MED H	HIGH																																																																																																																																																								
Pilot Orifice Size		.10	-	-	-	-																																																																																																																																																								
Temp. Rise 0F	45 - 75	.20	925	-	1095	1345																																																																																																																																																								
Ignition Type	IID	.30	905	-	1065	1295																																																																																																																																																								
Fan Control (ON/OFF)	TIME	.40	880	-	1030	1240																																																																																																																																																								
Limit Control (MAX)	135	.50	850	-	990	1180																																																																																																																																																								
Heat Anticipator	.58	.60	815	-	945	1115																																																																																																																																																								
		.70	780	-	895	1050																																																																																																																																																								
Compressor: FLA/LRA Run Cap. MFD./Volts Acc. Start Kit	COPELAND 17.9 / 90.5 35/440 NAMA001SC																																																																																																																																																													
Service Driers: Liquid/Charge Suction	16 cu in / 11oz 30 sq in																																																																																																																																																													
Ref. Charge (R-22 Oz.)	80																																																																																																																																																													
Clearances See Installation Instructions																																																																																																																																																														
<p>Note: Optimum operating charge will produce 15° - 25° F suction line superheat at compressor with 82° F outdoor Ambient and 80° F, Dry Bulb (67° F, Wet Bulb) indoor temperature at rated airflow.</p>																																																																																																																																																														

1065957
3-6-92
AH-1

Model or Style No. PGAB36E1K		Performance Data: 80° D.B. Indoor																																																																																																																																																												
Specifications		Low Wet Bulb (63°)					High Wet Bulb (69°)																																																																																																																																																							
		Coil - Internal					Rated 1200 CFM			.30 ESP Wet.																																																																																																																																																				
		Ambient Outdoor 5F	Approx. MBTUH	Sens. Total Ratio	PSIG. Liquid (Head)	PSIG. Suct.	Unit Amps	Ambient Outdoor 5F	Approx. MBTUH	Sens. Total Ratio	PSIG. Liquid (Head)	PSIG. Suct.	Unit Amps																																																																																																																																																	
Electrical: Voltage/Cycles/Phase Branch Circuit Ampacity Wire Size/Max. Ft. Time Delay Fuse Size Max. Fuse/HACR Brk. Boost Transformer	208/230/60/1 29.4 No. 10 / 50' 35 45 ---	65	34.7	0.87	180	66	14.3	65	38.0	0.61	194	75	15.0																																																																																																																																																	
		75	34.0	0.89	201	70	15.3	75	37.2	0.63	217	79	16.1																																																																																																																																																	
		85	33.4	0.91	229	73	16.3	85	36.5	0.65	247	83	17.2																																																																																																																																																	
		95	32.5	0.93	260	77	17.3	95	35.6	0.66	281	87	18.2																																																																																																																																																	
		105	31.0	0.94	292	80	18.2	105	33.9	0.67	315	91	19.2																																																																																																																																																	
		115	28.4	0.94	323	83	19.2	115	31.0	0.67	348	94	20.3																																																																																																																																																	
Fan Motor: H.P./Type FLA/LRA Speeds/CFM Cap. MFD/Volts	COND. EVAP. 1/3 PSC 3/4 PSC 1.4/13.57 5.6/12.8 1/3000 4/1645 5/370 15/370	<table border="1"> <thead> <tr> <th colspan="11">Heating</th> </tr> <tr> <th colspan="2">Gas Type</th> <th colspan="9">230V - Dry Coil</th> </tr> <tr> <th>Input (MBTUH)</th> <th>Output (MBTUH)</th> <th>TAP</th> <th>LOW</th> <th>MED L</th> <th>MED H</th> <th>HIGH</th> <th colspan="5" rowspan="8"> External Static Pressure Inches of W. C. </th> </tr> </thead> <tbody> <tr> <td>115 / 90</td> <td>95 / 75</td> <td>.10</td><td>-</td><td>-</td><td>-</td><td>-</td> </tr> <tr> <td></td><td></td> <td>.20</td><td>1070</td><td>1295</td><td>1490</td><td>1645</td> </tr> <tr> <td></td><td></td> <td>.30</td><td>1055</td><td>1270</td><td>1440</td><td>1580</td> </tr> <tr> <td></td><td></td> <td>.40</td><td>1040</td><td>1235</td><td>1385</td><td>1515</td> </tr> <tr> <td></td><td></td> <td>.50</td><td>1020</td><td>1195</td><td>1330</td><td>1450</td> </tr> <tr> <td></td><td></td> <td>.60</td><td>990</td><td>1145</td><td>1270</td><td>1385</td> </tr> <tr> <td></td><td></td> <td>.70</td><td>955</td><td>1095</td><td>1210</td><td>1315</td> </tr> <tr> <th colspan="2">Orifices</th> <th colspan="5">208V - Dry Coil</th> </tr> <tr> <td>43/46</td> <td></td> <th>TAP</th> <th>LOW</th> <th>MED L</th> <th>MED H</th> <th>HIGH</th> </tr> <tr> <td>Pilot Orifice Size</td> <td></td> <td>.10</td><td>-</td><td>-</td><td>-</td><td>-</td> </tr> <tr> <td>Temp. Rise 0F</td> <td>45 - 75</td> <td>.20</td><td>870</td><td>1090</td><td>1330</td><td>1585</td> </tr> <tr> <td>Ignition Type</td> <td>IID</td> <td>.30</td><td>860</td><td>1085</td><td>1300</td><td>1530</td> </tr> <tr> <td>Fan Control (ON/OFF)</td> <td>TIME</td> <td>.40</td><td>850</td><td>1055</td><td>1260</td><td>1480</td> </tr> <tr> <td>Limit Control (MAX)</td> <td>135</td> <td>.50</td><td>840</td><td>1030</td><td>1220</td><td>1425</td> </tr> <tr> <td>Heat Anticipator</td> <td>.58</td> <td>.60</td><td>825</td><td>1000</td><td>1170</td><td>1365</td> </tr> <tr> <td></td><td></td> <td>.70</td><td>805</td><td>960</td><td>1120</td><td>1300</td> </tr> </tbody> </table>											Heating											Gas Type		230V - Dry Coil									Input (MBTUH)	Output (MBTUH)	TAP	LOW	MED L	MED H	HIGH	External Static Pressure Inches of W. C.					115 / 90	95 / 75	.10	-	-	-	-			.20	1070	1295	1490	1645			.30	1055	1270	1440	1580			.40	1040	1235	1385	1515			.50	1020	1195	1330	1450			.60	990	1145	1270	1385			.70	955	1095	1210	1315	Orifices		208V - Dry Coil					43/46		TAP	LOW	MED L	MED H	HIGH	Pilot Orifice Size		.10	-	-	-	-	Temp. Rise 0F	45 - 75	.20	870	1090	1330	1585	Ignition Type	IID	.30	860	1085	1300	1530	Fan Control (ON/OFF)	TIME	.40	850	1055	1260	1480	Limit Control (MAX)	135	.50	840	1030	1220	1425	Heat Anticipator	.58	.60	825	1000	1170	1365			.70	805	960	1120	1300
Heating																																																																																																																																																														
Gas Type													230V - Dry Coil																																																																																																																																																	
Input (MBTUH)	Output (MBTUH)												TAP	LOW	MED L	MED H	HIGH	External Static Pressure Inches of W. C.																																																																																																																																												
115 / 90	95 / 75												.10	-	-	-	-																																																																																																																																													
													.20	1070	1295	1490	1645																																																																																																																																													
													.30	1055	1270	1440	1580																																																																																																																																													
													.40	1040	1235	1385	1515																																																																																																																																													
													.50	1020	1195	1330	1450																																																																																																																																													
													.60	990	1145	1270	1385																																																																																																																																													
		.70	955	1095	1210	1315																																																																																																																																																								
Orifices		208V - Dry Coil																																																																																																																																																												
43/46		TAP	LOW	MED L	MED H	HIGH																																																																																																																																																								
Pilot Orifice Size		.10	-	-	-	-																																																																																																																																																								
Temp. Rise 0F	45 - 75	.20	870	1090	1330	1585																																																																																																																																																								
Ignition Type	IID	.30	860	1085	1300	1530																																																																																																																																																								
Fan Control (ON/OFF)	TIME	.40	850	1055	1260	1480																																																																																																																																																								
Limit Control (MAX)	135	.50	840	1030	1220	1425																																																																																																																																																								
Heat Anticipator	.58	.60	825	1000	1170	1365																																																																																																																																																								
		.70	805	960	1120	1300																																																																																																																																																								
Compressor: FLA/LRA Run Cap. MFD./Volts Acc. Start Kit	COPELAND 17.9 / 90.5 35 / 440 NAMA001SC																																																																																																																																																													
Service Driers: Liquid/Charge Suction	16 cu in / 11oz 30 sq in																																																																																																																																																													
Ref. Charge (R-22 Oz.)	80																																																																																																																																																													
Clearances See Installation Instructions																																																																																																																																																														
<p>Note: Optimum operating charge will produce 15° - 25° F suction line superheat at compressor with 82° F outdoor Ambient and 80° F, Dry Bulb (67° F, Wet Bulb) indoor temperature at rated airflow.</p>																																																																																																																																																														

1065958
3-6-92
AH-2

Technical Service Data Sheets 1066136 & 1066215

Model or Style No. PGAB18B1K			Performance Data: 80° D.B. Indoor												
Specifications			Low Wet Bulb (63°)						High Wet Bulb (69°)						
			Coil – Internal						Rated 600 CFM .15 ESP Wet.						
			Ambient Outdoor °F	Approx. MBTUH	Sens. Total Ratio	PSIG. Liquid (Head)	PSIG. Suct.	Unit Amps	Ambient Outdoor °F	Approx. MBTUH	Sens. Total Ratio	PSIG. Liquid (Head)	PSIG. Suct.	Unit Amps	
Electrical: Voltage/Cycles/Phase Branch Circuit Ampacity Wire Size/Max. Ft. Time Delay Fuse Size Max. Fuse/HACR Brk. Boost Transformer	208/230/60/1 14.3 No. 14 / 40' 20 20 –		65	18.7	0.86	160	66	6.7	65	20.5	0.60	173	76	7.0	
			75	18.3	0.88	179	70	7.1	75	20.0	0.62	194	80	7.5	
			85	18.0	0.90	204	74	7.6	85	19.7	0.64	220	84	8.0	
			95	17.5	0.92	232	77	8.1	95	19.2	0.65	250	88	8.5	
			105	16.7	0.93	261	80	8.5	105	18.3	0.66	281	91	9.0	
			115	15.3	0.93	288	83	9.0	115	16.7	0.66	310	95	9.4	
Fan Motor: H.P./Type FLA/LRA Speeds/CFM Cap.MFD/Volts	COND. 1/6PSC .8/1.72 1/2250 5/370	EVAP. 1/6PSC 1.5/1.81 3/820 5/370	HEATING												
Compressor: FLA/LRA Run Cap. MFD./Volts Acc. Start Kit	COPELAND 9.6 / 50 25/370 NAMA001SC		Gas Type	Nat					External Static Pressure Inches of W. C.	230V – Dry Coil					
Service Driers: Liquid/Charge Suction	5 cu in / 5oz 17 sq in		Input (MBTUH)	40						TAP	LOW	MED L	MED H	HIGH	
			Output (MBTUH)	31						.10	–	–	–	–	
			Gas Valve	HW							.20	615	–	750	820
			Regulation Type	Snap							.30	585	–	715	785
			Manifold Pressure	3.5							.40	550	–	685	750
			Orifices	44							.50	515	–	645	715
			Pilot Orifice Size	.018							.60	470	–	600	670
Temp. Rise 0F	30–60						.70	415		–	550	615			
Ignition Type	IID						208V – Dry Coil								
Fan Control (ON/OFF)	TIME						TAP	LOW		MED L	MED H	HIGH			
Clearances See Installation Instructions			Limit Control (MAX)	160						.10	–	–	–	–	
			Heat Anticipator	.58						.20	530	–	660	730	
											.30	505	–	630	700
											.40	475	–	600	670
											.50	440	–	570	635
										.60	390	–	525	590	
										.70	330	–	470	535	
Note: Optimum operating charge will produce 15° – 25° F suction line superheat at compressor with 82° F outdoor Ambient and 80° F, Dry Bulb (67° F, Wet Bulb) indoor temperature at rated air flow.												1066136 3–6–92 AH–1			

Model or Style No. PGAB18C1K			Performance Data: 80° D.B. Indoor												
Specifications			Low Wet Bulb (63°)						High Wet Bulb (69°)						
			Coil – Internal						Rated 600 CFM .15 ESP Wet.						
			Ambient Outdoor °F	Approx. MBTUH	Sens. Total Ratio	PSIG. Liquid (Head)	PSIG. Suct.	Unit Amps	Ambient Outdoor °F	Approx. MBTUH	Sens. Total Ratio	PSIG. Liquid (Head)	PSIG. Suct.	Unit Amps	
Electrical: Voltage/Cycles/Phase Branch Circuit Ampacity Wire Size/Max. Ft. Time Delay Fuse Size Max. Fuse/HACR Brk. Boost Transformer	208/230/60/1 14.3 No. 14 / 40' 20 20 –		65	18.7	0.86	160	66	6.7	65	20.5	0.60	173	76	7.0	
			75	18.3	0.88	179	70	7.1	75	20.0	0.62	194	80	7.5	
			85	18.0	0.90	204	74	7.6	85	19.7	0.64	220	84	8.0	
			95	17.5	0.92	232	77	8.1	95	19.2	0.65	250	88	8.5	
			105	16.7	0.93	261	80	8.5	105	18.3	0.66	281	91	9.0	
			115	15.3	0.93	288	83	9.0	115	16.7	0.66	310	95	9.4	
Fan Motor: H.P./Type FLA/LRA Speeds/CFM Cap. MFD/Volts	COND. 1/6 PSC .8/1.72 1/2250 5/370	EVAP. 1/6 PSC 1.5/1.81 3/820 5/370	Heating												
Compressor: FLA/LRA Run Cap. MFD./Volts Acc. Start Kit	COPELAND 9.6 / 50 25/370 NAMA001SC		Gas Type	Nat					External Static Pressure Inches of W. C.	230V – Dry Coil					
Service Driers: Liquid/Charge Suction	5 cu in / 5 oz 17 sq in		Input (MBTUH)	60						TAP	LOW	MED L	MED H	HIGH	
			Output (MBTUH)	47						.10	–	–	–	–	
			Gas Valve	HW							.20	615	–	750	820
			Regulation Type	Snap							.30	585	–	715	785
			Manifold Pressure	3.5							.40	550	–	685	750
			Orifices	44							.50	515	–	645	715
			Pilot Orifice Size	.018							.60	470	–	600	670
Temp. Rise 0F	45–75						.70	415		–	550	615			
Ignition Type	IID						208V – Dry Coil								
Fan Control (ON/OFF)	TIME						TAP	LOW		MED L	MED H	HIGH			
Clearances See Installation Instructions			Limit Control (MAX)	135						.10	–	–	–	–	
			Heat Anticipator	.58						.20	530	–	660	730	
											.30	505	–	630	700
											.40	475	–	600	670
											.50	440	–	570	635
										.60	390	–	525	590	
										.70	330	–	470	535	
Note: Optimum operating charge will produce 15° – 25° F suction line superheat at compressor with 82° F outdoor Ambient and 80° F, Dry Bulb (67° F, Wet Bulb) indoor temperature at rated airflow.												1066215 3–6–92 AH–1			

Technical Service Data Sheets 1066308 & 1066309

Model or Style No. PGAA36C1K		Performance Data: 80° D.B. Indoor											
Specifications		Coil – Internal Rated 1200 CFM .20 ESP Wet.											
		Low Wet Bulb (63°)					High Wet Bulb (69°)						
		Amb. Outd.	Appx. MBTUH	Sens. Total Ratio	PSIG. Disch. (Head)	PSIG. Suct.	Unit Amp.	Amb. Outd.	Appx. MBTUH	Sens. Total Ratio	PSIG. Disch. (Head)	PSIG. Suct.	Unit Amp.
Electrical: Voltage/Phase/Hz Branch Circuit Ampacity Wire Size/Max. Ft. Time Delay Fuse Size Max. Fuse/HACR Brk. Boost Transformer	208/230–1–60 29.3 No. 10 / 58' 35 45 - - - -	65	34.2	.88	169	65	14.1	65	37.4	.62	183	74	14.9
		75	33.5	.90	190	69	15.1	75	36.6	.64	205	79	15.9
		85	32.9	.92	216	72	16.1	85	36.0	.66	233	82	17.0
		95	32.1	.94	245	76	17.1	95	35.1	.67	264	86	18.0
		105	30.5	.95	275	79	18.0	105	33.4	.68	297	90	19.0
115	27.9	.95	304	82	19.0	115	30.6	.68	328	93	20.0		
Fan Motor: H.P./Type FLA/LRA Speeds/CFM Cap. MFD/Volts	COND. EVAP. 1/3 PSC 1/2 PSC 1.4/3.57 3.6/7.5 1/3000 3/1435 5/370 15/370	Heating Performance Data					Blower Performance Data (Add 0.05 In. W. C. for wet coil)						
Compressor: FLA/LRA Run Cap. MFD./Volts Acc. Start Kit	COPELAND 19.5 / 82.0 35/440 NAMA001SC	Gas Type Input (MBTUH) Output (MBTUH) Gas Valve Regulation Type Manifold Pressure Orifices Pilot Orifice Size Temp. Rise 0F Ignition Type Fan Control (ON/OFF) Limit Control (MAX) Heat Anticipator	Nat 60 47 HW Snap 3.5 44 .018 30–60 IID TIME 150 .58	External Static Pressure Inches of W. C. CFM @ 230V – Dry Coil (No Filter) TAP LOW MED L MED H HIGH .10 – – – – .20 1110 – – 1270 1435 .30 1080 – – 1220 1375 .40 1045 – – 1165 1310 .50 1005 – – 1100 1245 .60 955 – – 1045 1175 .70 905 – – 990 1105 CFM @ 208V – Dry Coil (No Filter) TAP LOW MED L MED H HIGH .10 – – – – .20 925 – – 1095 1345 .30 905 – – 1065 1295 .40 880 – – 1030 1240 .50 850 – – 990 1180 .60 815 – – 945 1115 .70 780 – – 895 1050									
Service Driers: Liquid/Charge Suction	16 cu in / 11oz 30 sq in	Ref. Charge (R-22 Oz.) 81	Clearances See Installation Instructions	Note: Optimum operating charge will produce 15° – 25° F suction line superheat at compressor with 82° F outdoor ambient and 80° F Dry Bulb (67° F Wet Bulb) indoor temperature at rated airflow.									

1066308
9–17–92
AH–1

Model or Style No. PGAA36D1K		Performance Data: 80° D.B. Indoor											
Specifications		Coil – Internal Rated 1200 CFM .20 ESP Wet.											
		Low Wet Bulb (63°)					High Wet Bulb (69°)						
		Amb. Outd.	Appx. MBTUH	Sens. Total Ratio	PSIG. Disch. (Head)	PSIG. Suct.	Unit Amp.	Amb. Outd.	Appx. MBTUH	Sens. Total Ratio	PSIG. Disch. (Head)	PSIG. Suct.	Unit Amp.
Electrical: Voltage/Phase/Hz Branch Circuit Ampacity Wire Size/Max. Ft. Time Delay Fuse Size Max. Fuse/HACR Brk. Boost Transformer	208/230–1–60 29.3 No. 10 / 58' 35 45 - - - -	65	34.2	.88	169	65	14.1	65	37.4	.62	183	74	14.9
		75	33.5	.90	190	69	15.1	75	36.6	.64	205	79	15.9
		85	32.9	.92	216	72	16.1	85	36.0	.66	233	82	17.0
		95	32.1	.94	245	76	17.1	95	35.1	.67	264	86	18.0
		105	30.5	.95	275	79	18.0	105	33.4	.68	297	90	19.0
115	27.9	.95	304	82	19.0	115	30.6	.68	328	93	20.0		
Fan Motor: H.P./Type FLA/LRA Speeds/CFM Cap. MFD/Volts	COND. EVAP. 1/3 PSC 1/2 PSC 1.4/3.57 3.6/7.5 1/3000 3/1435 5/370 15/370	Heating Performance Data					Blower Performance Data (Add 0.05 In. W. C. for wet coil)						
Compressor: FLA/LRA Run Cap. MFD./Volts Acc. Start Kit	COPELAND 19.5 / 82.0 35/440 NAMA001SC	Gas Type Input (MBTUH) Output (MBTUH) Gas Valve Regulation Type Manifold Pressure Orifices Pilot Orifice Size Temp. Rise 0F Ignition Type Fan Control (ON/OFF) Limit Control (MAX) Heat Anticipator	Nat 90/75 70/59 HW Snap 3.5 43/46 .018 45–75 IID TIME 135 .58	External Static Pressure Inches of W. C. CFM @ 230V – Dry Coil (No Filter) TAP LOW MED L MED H HIGH .10 – – – – .20 1110 – – 1270 1435 .30 1080 – – 1220 1375 .40 1045 – – 1165 1310 .50 1005 – – 1100 1245 .60 955 – – 1045 1175 .70 905 – – 990 1105 CFM @ 208V – Dry Coil (No Filter) TAP LOW MED L MED H HIGH .10 – – – – .20 925 – – 1095 1345 .30 905 – – 1065 1295 .40 880 – – 1030 1240 .50 850 – – 990 1180 .60 815 – – 945 1115 .70 780 – – 895 1050									
Service Driers: Liquid/Charge Suction	16 cu in / 11oz 30 sq in	Ref. Charge (R-22 Oz.) 81	Clearances See Installation Instructions	Note: Optimum operating charge will produce 15° – 25° F suction line superheat at compressor with 82° F outdoor ambient and 80° F Dry Bulb (67° F Wet Bulb) indoor temperature at rated airflow.									

1066309
9–17–92
AH–1

Technical Service Data Sheets 1066310 & 1066431

Model or Style No. PGAA36E1K		Performance Data: 80° D.B. Indoor											
Specifications		Coil – Internal Rated 1200 CFM .20 ESP Wet.											
Electrical: Voltage/Phase/Hz Branch Circuit Ampacity Wire Size/Max. Ft. Time Delay Fuse Size Max. Fuse/HACR Brk. Boost Transformer		Low Wet Bulb (63°)					High Wet Bulb (69°)						
		Amb. Outd	Appx. MBTUH	Sens. Total Ratio	PSIG. Disch. (Head)	PSIG. Suct.	Unit Amp.	Amb. Outd	Appx. MBTUH	Sens. Total Ratio	PSIG. Disch. (Head)	PSIG. Suct.	Unit Amp.
208/230–1–60 31.3 No. 8 / 91' 40 50 – – – –		65	34.2	.88	169	65	14.1	65	37.4	.62	183	74	14.9
Fan Motor: H.P./Type FLA/LRA Speeds/CFM Cap. MFD/Volts		75	33.5	.90	190	69	15.1	75	36.6	.64	205	79	15.9
		85	32.9	.92	216	72	16.1	85	36.0	.66	233	82	17.0
COND. EVAP. 1/3 PSC 1/2 PSC 1.4/5.8 5.6/8.9 1/3000 4/1645 5/370 15/370		95	32.1	.94	245	76	17.1	95	35.1	.67	264	86	18.0
		105	30.5	.95	275	79	18.0	105	33.4	.68	297	90	19.0
Compressor: FLA/LRA Run Cap. MFD./Volts Acc. Start Kit		115	27.9	.95	304	82	19.0	115	30.6	.68	328	93	20.0
		Heating Performance Data					Blower Performance Data (Add 0.05 In. W. C. for wet coil)						
Service Driers: Liquid/Charge Suction		Gas Type		Nat		External Static Pressure Inches of W. C.							
		Input (MBTUH)		115/90									
Ref. Charge (R-22 Oz.) 81		Output (MBTUH)		95/75									
		Gas Valve		HW									
Clearances See Installation Instructions		Regulation Type		Snap									
		Manifold Pressure		3.5									
COPELAND 19.5 / 82.0 35/440 NAMA001SC		Orifices		43/46									
		Pilot Orifice Size		.018									
CFM @ 230V – Dry Coil (No Filter)		Temp. Rise 0F		45–75									
		Ignition Type		IID									
TAP LOW MED L MED H HIGH		Fan Control (ON/OFF)		TIME									
		Limit Control (MAX)		135									
CFM @ 208V – Dry Coil (No Filter)		Heat Anticipator		.58									
		TAP LOW MED L MED H HIGH		.10 – – – –									
TAP LOW MED L MED H HIGH		.20		1070 1295 1490 1645									
		.30		1055 1270 1440 1580									
TAP LOW MED L MED H HIGH		.40		1040 1235 1385 1515									
		.50		1020 1195 1330 1450									
TAP LOW MED L MED H HIGH		.60		990 1145 1270 1385									
		.70		955 1095 1210 1315									
TAP LOW MED L MED H HIGH		.10		– – – –									
		.20		870 1090 1330 1585									
TAP LOW MED L MED H HIGH		.30		860 1080 1300 1530									
		.40		850 1055 1260 1480									
TAP LOW MED L MED H HIGH		.50		840 1030 1220 1425									
		.60		825 1000 1170 1365									
TAP LOW MED L MED H HIGH		.70		805 960 1120 1300									

Note: Optimum operating charge will produce 15° – 25° F suction line superheat at compressor with 82° F outdoor ambient and 80° F Dry Bulb (67° F Wet Bulb) indoor temperature at rated airflow.

1066310
9–17–92
AH–1

Model or Style No. PGAA47F1K		Performance Data: 80° F Dry Bulb Indoor											
Specifications		Coil – Internal Rated 1600 CFM .30 ESP Wet.											
Electrical: Voltage–Phase–Hz Branch Circuit Ampacity Wire Size/Max. Ft. Time Delay/HACR Brk. Max. Fuse Size Boost Transformer		Low Wet Bulb (63°F)					High Wet Bulb (69°F)						
		Ambient Outdoor °F	Approx. MBTUH	Sens. Total Ratio	PSIG. Liquid (Head)	PSIG. Suct.	Unit Amps	Ambient Outdoor °F	Approx. MBTUH	Sens. Total Ratio	PSIG. Liquid (Head)	PSIG. Suct.	Unit Amps
208/230–1–60 36.0 No. 6 / 97' 45 50 – – – –		65	48.3	0.86	183	61	20.2	65	52.9	0.60	198	70	21.3
Fan Motor: H.P./Type FLA/LRA Speeds/CFM Cap. MFD/Volts		75	47.3	0.88	205	64	21.6	75	51.7	0.62	221	74	22.8
		85	45.6	0.90	233	68	23.0	85	50.8	0.64	251	77	24.3
COND. EVAP. 1/2 PSC 1 PSC 1.8 / 6.42 4.6 / 7.90 1 / 4500 3 / 2185 7.5 / 440 20 / 370		95	45.3	0.92	265	71	24.4	95	49.5	0.65	286	81	25.8
		105	43.1	0.93	297	74	25.8	105	47.2	0.66	321	84	27.2
Compressor: FLA/LRA Run Cap. MFD./Volts Acc. Start Kit		115	39.4	0.93	328	77	27.2	115	43.2	0.66	354	87	28.7
		Heating Data					Blower Performance Data (add 0.05 In. W. C. for wet coil)						
Service Driers: Liquid/Charge Suction		Gas Type		Nat		External Static Pressure Inches of W. C.							
		Input (MBTUH)		135 / 110									
Ref. Charge (R-22 Oz.) 124		Output (MBTUH)		106 / 87									
		Gas Valve		HW									
Clearances See Installation Instructions		Regulation Type		Snap									
		Manifold Pressure		3.5									
COPELAND 23.7 / 129 40 / 440 NAMA001SC		Orifices		43/46									
		Pilot Orifice Size		.018									
CFM @ 230V – Dry Coil (no filter)		Temp. Rise 0F		35–65									
		Ignition Type		IID									
TAP LOW MED L MED H HIGH		Fan Control (ON/OFF)		TIME									
		Limit Control (MAX)		135									
CFM @ 208V – Dry Coil (no filter)		Heat Anticipator		.58									
		TAP LOW MED L MED H HIGH		.10 1445 – – – – 1560 2025									
TAP LOW MED L MED H HIGH		.20		1430 – – – – 1545 1995									
		.30		1415 – – – – 1530 1960									
TAP LOW MED L MED H HIGH		.40		1390 – – – – 1505 1915									
		.50		1355 – – – – 1475 1870									
TAP LOW MED L MED H HIGH		.60		1320 – – – – 1435 1810									
		.70		1275 – – – – 1390 1745									

Note: Optimum operating charge will produce 15° – 25° F suction line superheat at compressor with 82° F outdoor ambient and 80° F dry bulb (67° F wet bulb) indoor temperature at rated airflow.

1066431
11–13–92
AH–1

Technical Service Data Sheets 1066618 & 1066619

Style No:	PGAD30D1K		Outdoor Ambient Temperature - Degrees F. Dry Bulb																Outdoor Ambient Temperature					
Voltage	208 / 230	Gas Type	NAT	IDB	75				85				95				105				115			
					59	63	67	71	59	63	67	71	59	63	67	71	59	63	67	71	59	63	67	71
Phase	1	Std Input	90	Entering Indoor Temperature - Degrees F. Wet Bulb																Entering Indoor Temperature				
Ampacity	20.5	Low Fire Input	75	Entering Indoor Temperature - Degrees F. Wet Bulb																Entering Indoor Temperature				
Wire Ga/Ft	12 / 40	Std Output	69	Entering Indoor Temperature - Degrees F. Wet Bulb																Entering Indoor Temperature				
Delay Fuse	25	Low Fire Output	59	Entering Indoor Temperature - Degrees F. Wet Bulb																Entering Indoor Temperature				
Max. Fuse	30	Gas Valve	HW	Entering Indoor Temperature - Degrees F. Wet Bulb																Entering Indoor Temperature				
Compressor	COPELAND	Regulation	SNAP	Entering Indoor Temperature - Degrees F. Wet Bulb																Entering Indoor Temperature				
RLA	13.5	Manifold Press	3.5	Entering Indoor Temperature - Degrees F. Wet Bulb																Entering Indoor Temperature				
LRA	76	Std orifice	43	Entering Indoor Temperature - Degrees F. Wet Bulb																Entering Indoor Temperature				
Cap MFD/V	35 / 370	Low Fire Orifice	46	Entering Indoor Temperature - Degrees F. Wet Bulb																Entering Indoor Temperature				
CC Heater		Pilot Orifice	0.018	Entering Indoor Temperature - Degrees F. Wet Bulb																Entering Indoor Temperature				
Start Kit	NAMA001SC	Temp Rise	45-75	Entering Indoor Temperature - Degrees F. Wet Bulb																Entering Indoor Temperature				
Cond & Evap	Cond	Evap	IID	Entering Indoor Temperature - Degrees F. Wet Bulb																Entering Indoor Temperature				
Type	Fan	Blower	TIME	Entering Indoor Temperature - Degrees F. Wet Bulb																Entering Indoor Temperature				
Size	20	DD10-8A	Limit Set Max	Entering Indoor Temperature - Degrees F. Wet Bulb																Entering Indoor Temperature				
Motor-HP	1/3	1/3	Heat Antic	Entering Indoor Temperature - Degrees F. Wet Bulb																Entering Indoor Temperature				
Type	PSC	PSC		Entering Indoor Temperature - Degrees F. Wet Bulb																Entering Indoor Temperature				
FLA	1.4	2.3		Entering Indoor Temperature - Degrees F. Wet Bulb																Entering Indoor Temperature				
LRA	3.57	4.1		Entering Indoor Temperature - Degrees F. Wet Bulb																Entering Indoor Temperature				
RPM	1135	1100		Entering Indoor Temperature - Degrees F. Wet Bulb																Entering Indoor Temperature				
Cap MFD/V	5/370	5/370		Entering Indoor Temperature - Degrees F. Wet Bulb																Entering Indoor Temperature				
PTCR				Entering Indoor Temperature - Degrees F. Wet Bulb																Entering Indoor Temperature				
Hi Press				Entering Indoor Temperature - Degrees F. Wet Bulb																Entering Indoor Temperature				
Low Press				Entering Indoor Temperature - Degrees F. Wet Bulb																Entering Indoor Temperature				
Operating Chg (No Lines)*	(R-22 Oz)			Entering Indoor Temperature - Degrees F. Wet Bulb																Entering Indoor Temperature				
Service Driers				Entering Indoor Temperature - Degrees F. Wet Bulb																Entering Indoor Temperature				
Liquid/Chg	8 Cu In / 7 oz			Entering Indoor Temperature - Degrees F. Wet Bulb																Entering Indoor Temperature				
Suction	30 Sq In			Entering Indoor Temperature - Degrees F. Wet Bulb																Entering Indoor Temperature				
Unit Weight	425			Entering Indoor Temperature - Degrees F. Wet Bulb																Entering Indoor Temperature				
				Air Delivery in CFM - Dry Coil - No Filter (Add .05 static for Wet Coil)																				
				230 Volt External Static Press (Inch Water Column)								208 Volt External Static Press (Inch Water Column)								208				
				Speed Tap								Speed Tap								Speed Tap				
				0.1 0.2 0.3 0.4 0.5 0.6 0.7								0.1 0.2 0.3 0.4 0.5 0.6 0.7								0.1 0.2 0.3 0.4 0.5 0.6 0.7				
				HI								HI								HI				
				MD HI								MD HI								MD HI				
				MD LO								MD LO								MD LO				
				LO								LO								LO				

Style No:	PGAD36D1K		Outdoor Ambient Temperature - Degrees F. Dry Bulb																Outdoor Ambient Temperature					
Voltage	208 / 230	Gas Type	NAT	IDB	75				85				95				105				115			
					59	63	67	71	59	63	67	71	59	63	67	71	59	63	67	71	59	63	67	71
Phase	1	Std Input	90	Entering Indoor Temperature - Degrees F. Wet Bulb																Entering Indoor Temperature				
Ampacity	27.4	Low Fire Input	75	Entering Indoor Temperature - Degrees F. Wet Bulb																Entering Indoor Temperature				
Wire Ga/Ft	10 / 50	Std Output	70	Entering Indoor Temperature - Degrees F. Wet Bulb																Entering Indoor Temperature				
Delay Fuse	35	Low Fire Output	59	Entering Indoor Temperature - Degrees F. Wet Bulb																Entering Indoor Temperature				
Max. Fuse	45	Gas Valve	HW	Entering Indoor Temperature - Degrees F. Wet Bulb																Entering Indoor Temperature				
Compressor	COPELAND	Regulation	SNAP	Entering Indoor Temperature - Degrees F. Wet Bulb																Entering Indoor Temperature				
RLA	17.9	Manifold Press	3.5	Entering Indoor Temperature - Degrees F. Wet Bulb																Entering Indoor Temperature				
LRA	90.5	Std orifice	43	Entering Indoor Temperature - Degrees F. Wet Bulb																Entering Indoor Temperature				
Cap MFD/V	35 / 440	Low Fire Orifice	46	Entering Indoor Temperature - Degrees F. Wet Bulb																Entering Indoor Temperature				
CC Heater		Pilot Orifice	0.018	Entering Indoor Temperature - Degrees F. Wet Bulb																Entering Indoor Temperature				
Start Kit	NAMA001SC	Temp Rise	45-75	Entering Indoor Temperature - Degrees F. Wet Bulb																Entering Indoor Temperature				
Cond & Evap	Cond	Evap	IID	Entering Indoor Temperature - Degrees F. Wet Bulb																Entering Indoor Temperature				
Type	Fan	Blower	TIME	Entering Indoor Temperature - Degrees F. Wet Bulb																Entering Indoor Temperature				
Size	20	DD11-9A	Limit Set Max	Entering Indoor Temperature - Degrees F. Wet Bulb																Entering Indoor Temperature				
Motor-HP	1/3	1/2	Heat Antic	Entering Indoor Temperature - Degrees F. Wet Bulb																Entering Indoor Temperature				
Type	PSC	PSC		Entering Indoor Temperature - Degrees F. Wet Bulb																Entering Indoor Temperature				
FLA	1.4	3.6		Entering Indoor Temperature - Degrees F. Wet Bulb																Entering Indoor Temperature				
LRA	3.57	7.5		Entering Indoor Temperature - Degrees F. Wet Bulb																Entering Indoor Temperature				
RPM	1135	1125		Entering Indoor Temperature - Degrees F. Wet Bulb																Entering Indoor Temperature				
Cap MFD/V	5/370	15/370		Entering Indoor Temperature - Degrees F. Wet Bulb																Entering Indoor Temperature				
PTCR				Entering Indoor Temperature - Degrees F. Wet Bulb																Entering Indoor Temperature				
Hi Press				Entering Indoor Temperature - Degrees F. Wet Bulb																Entering Indoor Temperature				
Low Press				Entering Indoor Temperature - Degrees F. Wet Bulb																Entering Indoor Temperature				
Operating Chg (No Lines)*	(R-22 Oz)			Entering Indoor Temperature - Degrees F. Wet Bulb																Entering Indoor Temperature				
Service Driers				Entering Indoor Temperature - Degrees F. Wet Bulb																Entering Indoor Temperature				
Liquid/Chg	16 Cu In / 11 oz			Entering Indoor Temperature - Degrees F. Wet Bulb																Entering Indoor Temperature				
Suction	30 Sq In			Entering Indoor Temperature - Degrees F. Wet Bulb																Entering Indoor Temperature				
Unit Weight	435			Entering Indoor Temperature - Degrees F. Wet Bulb																Entering Indoor Temperature				
				Air Delivery in CFM - Dry Coil - No Filter (Add .05 static for Wet Coil)																				
				230 Volt External Static Press (Inch Water Column)								208 Volt External Static Press (Inch Water Column)								208				
				Speed Tap								Speed Tap								Speed Tap				
				0.1 0.2 0.3 0.4 0.5 0.6 0.7								0.1 0.2 0.3 0.4 0.5 0.6 0.7								0.1 0.2 0.3 0.4 0.5 0.6 0.7				
				HI								HI								HI				
				MD HI								MD HI								MD HI				
				MD LO								MD LO								MD LO				
				LO								LO								LO				

Technical Service Data Sheets 106620 & 1066941

Table for PGAD36E1K showing performance metrics like Voltage, Ampacity, Wire Ga/Ft, Delay Fuse, Max. Fuse, Compressor, RLA, LRA, Cap MFD/V, CC Heater, Start Kit, Cond & Evap, Type, Size, Motor-HP, Type, FLA, LRA, RPM, Cap MFD/V, PTCR, Hi Press, Low Press, Operating Chg, Service Driers, Liquid/Chg, Suction, and Unit Weight across various ambient temperatures and conditions.

Table for PGAD60E1K showing performance metrics like Voltage, Ampacity, Wire Ga/Ft, Delay Fuse, Max. Fuse, Compressor, RLA, LRA, Cap MFD/V, CC Heater, Start Kit, Cond & Evap, Type, Size, Motor-HP, Type, FLA, LRA, RPM, Cap MFD/V, PTCR, Hi Press, Low Press, Operating Chg, Service Driers, Liquid/Chg, Suction, and Unit Weight across various ambient temperatures and conditions.

Technical Service Data Sheets 1066942 & 1066943

Style No:	PGAD60G1K				Outdoor Ambient Temperature - Degrees F. Dry Bulb																Outdoor Ambient Temperature						
					75				85				95				105				115						
					Entering Indoor Temperature - Degrees F. Wet Bulb																Entering Indoor Temperature						
					59 63 67 71				59 63 67 71				59 63 67 71				59 63 67 71				59 63 67 71						
Voltage	208 / 230			Gas Type	NAT	IDB																					
Phase	1						Std Input	150																			
Ampacity	43.9			Low Fire Input	130	70																					
Wire Ga/Ft	6 / 76						Std Output	119																			
Delay Fuse	60			Low Fire Output	102	75																					
Max. Fuse	70						Gas Valve	HW																			
Compressor	COPELAND			Regulation	SNAP	70																					
							Manifold Press	3.5																			
LRA	169			Std orifice	43	80																					
Cap MFD/V	80 / 440						Low Fire Orifice	46																			
CC Heater				Pilot Orifice	0.018	85																					
Start Kit	NAMA001SC						Temp Rise	35 - 65																			
Cond & Evap	Cond	Evap		Ignition Type	IID	70																					
	Type	Fan	Blower				Fan On/Off	TIME																			
Size	22		DD11-11	Limit Set Max	130	80																					
Motor-HP	1/2		1				Heat Antic	0.58																			
Type	PSC		PSC	FLA	1.8	6																					
LRA	6		15.1				RPM	1145	1140																		
Cap MFD/V	7.5/440		20/370	PTCR	Hi Press	Low Press																					
Operating Chg (No Lines)*	(R-22 Oz) 215																										
Service Driers	30 Cu In / 17 oz																										
Liquid/Chg	30 Sq In																										
Suction	30 Sq In																										
Unit Weight	630																			1066942							
				Air Delivery in CFM - Dry Coil - No Filter (Add .05 static for Wet Coil)																							
				230 Volt External Static Press (Inch Water Column)																208 Volt External Static Press (Inch Water Column)							
				Speed Tap 0.1 0.2 0.3 0.4 0.5 0.6 0.7																Speed Tap 0.1 0.2 0.3 0.4 0.5 0.6 0.7							
				HI 2470 2400 2325 2250 2170 2085 2000																HI 2380 2315 2250 2185 2105 2020 1940							
				MD HI 2395 2335 2270 2200 2125 2050 1965																MD HI 2310 2250 2185 2125 2060 1980 1905							
				MD LO 2260 2205 2145 2080 2015 1940 1865																MD LO 2090 2045 1995 1945 1890 1820 1750							
				LO 2140 2095 2040 1985 1920 1855 1780																LO 1915 1885 1845 1805 1755 1700 1640				1066943			

Style No:	PGAD47D1K				Outdoor Ambient Temperature - Degrees F. Dry Bulb																Outdoor Ambient Temperature						
					75				85				95				105				115						
					Entering Indoor Temperature - Degrees F. Wet Bulb																Entering Indoor Temperature						
					59 63 67 71				59 63 67 71				59 63 67 71				59 63 67 71				59 63 67 71						
Voltage	208 / 230			Gas Type	NAT	IDB																					
Phase	1						Std Input	90																			
Ampacity	35.8			Low Fire Input	75	70																					
Wire Ga/Ft	8 / 61						Std Output	71																			
Delay Fuse	45			Low Fire Output	60	75																					
Max. Fuse	50						Gas Valve	HW																			
Compressor	COPELAND			Regulation	SNAP	70																					
							Manifold Press	3.5																			
LRA	129			Std orifice	43	80																					
Cap MFD/V	60 / 440						Low Fire Orifice	46																			
CC Heater				Pilot Orifice	0.018	85																					
Start Kit	NAMA001SC						Temp Rise	30 - 60																			
Cond & Evap	Cond	Evap		Ignition Type	IID	70																					
	Type	Fan	Blower				Fan On/Off	TIME																			
Size	22		DD10-9	Limit Set Max	135	80																					
Motor-HP	1/2		1/2				Heat Antic	0.58																			
Type	PSC		PSC	FLA	1.8	4.4																					
LRA	6		8.6				RPM	1145	1125																		
Cap MFD/V	7.5/440		15/370	PTCR	Hi Press	Low Press																					
Operating Chg (No Lines)*	(R-22 Oz) 215																										
Service Driers	30 Cu In / 17 oz																										
Liquid/Chg	30 Sq In																										
Suction	30 Sq In																										
Unit Weight	600																			1066943							
				Air Delivery in CFM - Dry Coil - No Filter (Add .05 static for Wet Coil)																							
				230 Volt External Static Press (Inch Water Column)																208 Volt External Static Press (Inch Water Column)							
				Speed Tap 0.1 0.2 0.3 0.4 0.5 0.6 0.7																Speed Tap 0.1 0.2 0.3 0.4 0.5 0.6 0.7							
				HI 1925 1860 1795 1725 1650 1570 1485																HI 1805 1755 1700 1640 1575 1500 1415							
				MD HI 1785 1735 1680 1620 1560 1485 1405																MD HI 1610 1580 1540 1495 1440 1375 1300							
				MD LO 1570 1540 1505 1465 1415 1380 1280																MD LO 1385 1355 1330 1300 1265 1215 1155							
				LO 1485 1460 1430 1395 1345 1290 1225																LO 1270 1265 1250 1225 1190 1140 1085				1066943			

Technical Service Data Sheets 1066946 & 1067908

Style No:	PGAD42E1K		Outdoor Ambient Temperature - Degrees F. Dry Bulb															Outdoor Ambient Temperature									
			75					85					95					105					115				
			Entering Indoor Temperature - Degrees F. Wet Bulb															Entering Indoor Temperature									
Voltage	208 / 230		Gas Type	NAT	IDB																						
Phase	1		Std Input	115																							
Ampacity	31		Low Fire Input	95																							
Wire Ga/Ft	8 / 72		Std Output	90																							
Delay Fuse	40		Low Fire Output	75																							
Max. Fuse	50		Gas Valve	HW	70	MBh	38.6	40.0	43.8	-	37.6	39.0	42.8	-	36.7	38.1	41.7	-	34.9	36.2	39.6	-	32.3	33.5	36.7	-	
Compressor	COPELAND		Regulation	SNAP		S/T	0.76	0.64	0.44	-	0.78	0.65	0.45	-	0.81	0.68	0.47	-	0.84	0.70	0.49	-	0.85	0.71	0.49	-	
RLA	19.9		Manifold Press	3.5		AMPS	16.1	16.4	16.8	-	17.2	17.5	18.0	-	18.2	18.5	19.0	-	19.1	19.5	20.1	-	20.1	20.5	21.1	-	
LRA	107		Std orifice	43	HI PR	165	178	188	-	188	202	213	-	214	230	243	-	241	259	273	-	266	286	302	-		
Cap MFD/V	40 / 440		Low Fire Orifice	46	LO PR	66	71	77	-	69	73	80	-	73	77	84	-	76	81	88	-	79	84	91	-		
CC Heater			Pilot Orifice	0.018	75	MBh	39.2	40.4	43.7	46.9	38.3	39.4	42.7	45.8	37.4	38.5	41.6	44.7	35.5	36.5	39.5	42.4	32.9	33.8	36.6	39.3	
Start Kit	NAMA001SC		Temp Rise	35 - 65		S/T	0.87	0.78	0.59	0.38	0.89	0.80	0.60	0.39	0.92	0.82	0.62	0.40	0.95	0.85	0.65	0.42	0.96	0.86	0.65	0.42	
Cond & Evap	Cond	Evap	Ignition Type	IID		AMPS	16.2	16.5	16.9	17.5	17.3	17.7	18.1	18.7	18.3	18.7	19.2	19.8	19.3	19.7	20.2	20.9	20.2	20.6	21.2	21.9	
Type	Fan	Blower	Fan On/Off	TIME	HI PR	167	179	190	198	190	204	216	225	216	233	246	256	243	262	276	288	269	289	305	318		
Size	22	DD10-9	Limit Set Max	140	LO PR	67	71	78	83	70	74	81	86	73	78	85	91	77	82	89	95	79	85	92	98		
Motor-HP	1/2	1/2	Heat Antic	0.58	80	MBh	39.9	40.8	43.6	46.6	39.0	39.8	42.5	45.5	38.0	38.8	41.5	44.4	36.1	36.9	39.4	42.1	33.5	34.2	36.5	39.0	
Type	PSC	PSC				S/T	0.95	0.89	0.73	0.54	0.98	0.92	0.75	0.56	1.00	0.95	0.77	0.58	1.00	0.98	0.80	0.60	1.00	0.99	0.81	0.60	
FLA	1.8	4.4				AMPS	16.3	16.6	17.1	17.6	17.4	17.8	18.3	18.9	18.4	18.8	19.3	19.9	19.4	19.8	20.4	21.0	20.4	20.8	21.4	22.1	
LRA	6	8.6			HI PR	168	181	191	200	192	206	218	227	218	235	248	259	246	264	279	291	271	292	308	322		
RPM	1145	1125			LO PR	68	72	79	84	70	75	82	87	74	79	86	92	78	83	90	96	80	85	93	99		
Cap MFD/V	7.5/440	15/370			85	MBh	40.6	41.4	43.4	46.3	39.6	40.4	42.3	45.2	38.7	39.4	41.3	44.1	36.7	37.5	39.2	41.9	34.0	34.7	36.3	38.8	
PTCR						S/T	1.00	0.96	0.87	0.71	1.00	0.99	0.89	0.72	1.00	1.00	0.92	0.75	1.00	1.00	0.96	0.78	1.00	1.00	0.96	0.78	
Hi Press						AMPS	16.4	16.7	17.2	17.7	17.6	17.9	18.4	19.0	18.6	19.0	19.5	20.1	19.6	20.0	20.5	21.2	20.5	21.0	21.6	22.3	
Low Press					HI PR	170	183	193	202	194	208	220	229	220	237	250	261	248	267	282	294	274	295	311	325		
Operating Chg (No Lines)*	(R-22 Oz) 180				LO PR	69	73	80	85	71	76	83	88	75	80	87	93	78	83	91	97	81	86	94	100		
Service Driers					Air Delivery in CFM - Dry Coil - No Filter (Add .05 static for Wet Coil)															208							
Liquid/Chg	16 Cu In / 11 oz				230 Volt					208 Volt																	
Suction	30 Sq In				External Static Press (Inch Water Column)										Speed Tap												
Unit Weight	580				Speed Tap										0.1 0.2 0.3 0.4 0.5 0.6 0.7												
					HI										1805 1755 1700 1640 1575 1500 1415												
					MD HI										1610 1580 1540 1495 1440 1375 1300												
					MD LO										1385 1355 1330 1300 1265 1215 1155												
					LO										1270 1265 1250 1225 1190 1140 1085												

Model or Style No. PGAA18B1K		Performance Data: 80° D.B. Indoor																	
Specifications		Coil - Internal																	
		Rated 600 CFM .15 ESP Wet.																	
		Low Wet Bulb (63°)							High Wet Bulb (69°)										
		Amb. Outd	Appx. MBTUH	Sens. Total Ratio	PSIG. Disch. (Head)	PSIG. Suct.	Unit Amp.	Amb. Outd	Appx. MBTUH	Sens. Total Ratio	PSIG. Disch. (Head)	PSIG. Suct.	Unit Amp.						
Electrical:	208/230-1-60	65	18.7	.86	165	63	7.2	65	20.5	.60	178	72	7.6						
Voltage/Phase/Hz	14.0	75	18.3	.88	184	67	7.7	75	20.0	.62	199	76	8.1						
Branch Circuit Ampacity	No. 14 / 40'	85	18.0	.90	210	70	8.2	85	19.7	.64	226	80	8.7						
Wire Size/Max. Ft.	20	95	17.5	.92	238	73	8.7	95	19.2	.65	257	84	9.2						
Time Delay Fuse Size	20	105	16.7	.93	268	76	9.2	105	18.3	.66	289	87	9.7						
Max. Fuse/HACR Brk.	20	115	15.3	.93	296	79	9.7	115	16.7	.66	319	90	10.2						
Boost Transformer	-																		
Fan Motor:	COND. EVAP.																		
H.P./Type	1/6 1/6																		
FLA/LRA	PSC PSC																		
Speeds/CFM	.8/1.72 1.5/1.81																		
Cap. MFD/Volts	1/2250 3/820																		
	5/370 5/370																		
Compressor:	Copeland (Recip)																		
FLA/LRA	9.4/49																		
Run Cap. MFD./Volts	25/370																		
Acc. Start Kit	NAMA001SC																		
Service Driers:	5 cu in / 5oz																		
Liquid/Charge	17 sq in																		
Suction																			
Ref. Charge (R-22 Oz.)	57																		
Clearances	See Installation Instructions																		
		Heating Performance Data							Blower Performance Data (Add 0.05 In. W.C. for wet coil)										
		Gas Type	Nat				External Static Pressure												
		Input (MBTUH)	40				Inches of W. C.												
		Output (MBTUH)	31				TAP												
		Gas Valve (HSP)	HW				LOW												
		Regulation Type	Snap				MED L												
		Manifold Pressure	3.5				MED H												
		Orifices	44				HIGH												
		Pilot Orifice Size	.018																
		Temp. Rise 0F	30-60																
		Ignition Type	HSP																
		Fan Control (ON/OFF)	TIME																
		Limit Control (MAX)	160																
		Heat Anticipator	.58																

Note: Optimum operating charge will produce 15° - 25° F suction line superheat at compressor with 82° F outdoor ambient and 80° F Dry Bulb (67° F Wet Bulb) indoor temperature at rated airflow.

1067908
9-22-94
AH-1

Technical Service Data Sheets 1067909 & 1067910

Model or Style No. PGAA18C1K		Performance Data: 80° D.B. Indoor											
Specifications		Coil – Internal Rated 600 CFM .15 ESP Wet.											
		Low Wet Bulb (63°)					High Wet Bulb (69°)						
		Amb. Outd	Appx. MBTUH	Sens. Total Ratio	PSIG. Disch. (Head)	PSIG. Suct.	Unit Amp.	Amb. Outd	Appx. MBTUH	Sens. Total Ratio	PSIG. Disch. (Head)	PSIG. Suct.	Unit Amp.
Electrical: Voltage/Phase/Hz Branch Circuit Ampacity Wire Size/Max. Ft. Time Delay Fuse Size Max. Fuse/HACR Brk. Boost Transformer	208/230–1–60 14.0 No. 14 / 40' 20 20 –	65	18.7	.86	165	63	7.2	65	20.5	.60	178	72	7.6
		75	18.3	.88	184	67	7.7	75	20.0	.62	199	76	8.1
		85	18.0	.90	210	70	8.2	85	19.7	.64	226	80	8.7
		95	17.5	.92	238	73	8.7	95	19.2	.65	257	84	9.2
		105	16.7	.93	268	76	9.2	105	18.3	.66	289	87	9.7
115	15.3	.93	296	79	9.7	115	16.7	.66	319	90	10.2		
Fan Motor: H.P./Type FLA/LRA Speeds/CFM Cap. MFD/Volts	COND. EVAP. 1/6 1/6 PSC PSC .8/1.72 1.5/1.81 1/2250 3/820 5/370 5/370	Heating Performance Data					Blower Performance Data (Add 0.05 In. W.C. for wet coil)						
Compressor: FLA/LRA Run Cap. MFD./Volts Acc. Start Kit	Copeland (Recip) 9.4/49 25/370 NAMA001SC	Gas Type		Nat		External Static Pressure Inches of W. C.							
		Input (MBTUH)		60									
Output (MBTUH)		47											
Gas Valve (HSP)		HW											
Regulation Type		Snap											
Manifold Pressure		3.5											
Orifices		44											
Pilot Orifice Size		.018											
Temp. Rise 0F		45–75											
Ignition Type		HSP											
Service Driers: Liquid/Charge Suction	5 cu in / 5oz 17 sq in	Fan Control (ON/OFF)		TIME									
		Limit Control (MAX)		135									
Clearances See Installation Instructions		Heat Anticipator		.58									
Ref. Charge (R-22 Oz.) 57													
Note: Optimum operating charge will produce 15° – 25° F suction line superheat at compressor with 82° F outdoor ambient and 80° F Dry Bulb (67° F Wet Bulb) indoor temperature at rated airflow.										1067909 9-22-94 AH-1			

Model or Style No. PGAA24B1K		Performance Data: 80° D.B. Indoor												
Specifications		Coil – Internal Rated 800 CFM .15 ESP Wet.												
		Low Wet Bulb (63°)					High Wet Bulb (69°)							
		Amb. Outd	Appx. MBTUH	Sens. Total Ratio	PSIG. Disch. (Head)	PSIG. Suct.	Unit Amp.	Amb. Outd	Appx. MBTUH	Sens. Total Ratio	PSIG. Disch. (Head)	PSIG. Suct.	Unit Amp.	
Electrical: Voltage/Phase/Hz Branch Circuit Ampacity Wire Size/Max. Ft. Time Delay Fuse Size Max. Fuse/HACR Brk. Boost Transformer	208/230–1–60 16.8 No. 12 / 50' 20 25 –	65	24.8	.86	180	64	9.9	65	27.1	.60	194	73	10.	
		75	4						75	26.5	.62	217	77	11.
		85	24.2	.88	201	68	10.6	85	26.5	.62	217	77	11.	
		95	1						95	26.1	.64	247	81	11.
		105	23.8	.90	229	71	11.2	105	26.1	.64	247	81	11.	
115	9						115	25.4	.65	281	85	12.		
Fan Motor: H.P./Type FLA/LRA Speeds/CFM Cap. MFD/Volts	COND. EVAP. 1/6 1/4PSC PSC 2.1/3.08 .8/1.72 4/995 1/2250 5/370 5/370	Heating Performance Data					Blower Performance Data (Add 0.05 In. W.C. for wet coil)							
Compressor: FLA/LRA Run Cap. MFD./Volts Acc. Start Kit	Copeland (Recip) 11.2 / 61 35/370 NAMA001SC	Gas Type		Nat		External Static Pressure Inches of W. C.								
		Input (MBTUH)		40										
Output (MBTUH)		31												
Gas Valve (HSP)		HW												
Regulation Type		Snap												
Manifold Pressure		3.5												
Orifices		44												
Pilot Orifice Size		.018												
Temp. Rise 0F		30–60												
Ignition Type		HSP												
Service Driers: Liquid/Charge Suction	8 cu in / 7oz 30 sq in	Fan Control (ON/OFF)		TIME										
		Limit Control (MAX)		160										
Clearances See Installation Instructions		Heat Anticipator		.58										
Ref. Charge (R-22 Oz.) 64														
Note: Optimum operating charge will produce 15° – 25° F suction line superheat at compressor with 82° F outdoor ambient and 80° F Dry Bulb (67° F Wet Bulb) indoor temperature at rated airflow.										1067910 9-22-94 AH-1				

Technical Service Data Sheets 1067911 & 1067912

Model or Style No. PGAA24C1K		Performance Data: 80° D.B. Indoor											
Specifications		Coil – Internal Rated 800 CFM .15 ESP Wet.											
		Low Wet Bulb (63°)					High Wet Bulb (69°)						
		Amb. Outd	Appx. MBTUH	Sens. Total Ratio	PSIG. Disch. (Head)	PSIG. Suct.	Unit Amp.	Amb. Outd	Appx. MBTUH	Sens. Total Ratio	PSIG. Disch. (Head)	PSIG. Suct.	Unit Amp.
Electrical: Voltage/Phase/Hz Branch Circuit Ampacity Wire Size/Max. Ft. Time Delay Fuse Size Max. Fuse/HACR Brk. Boost Transformer	208/230–1–60	65	24.8	.86	180	64	9.9	65	27.1	.60	194	73	10.4
	16.8	75	24.2	.88	201	68	10.6	75	26.5	.62	217	77	11.1
	No. 12 / 50'	85	23.8	.90	229	71	11.2	85	26.1	.64	247	81	11.9
	20	95	23.2	.92	261	74	11.9	95	25.4	.65	281	85	12.6
	25	105	22.1	.93	293	77	12.6	105	24.2	.66	316	88	13.3
---	---	115	20.2	.93	323	80	13.3	115	22.1	.66	349	92	14.0
Fan Motor: H.P./Type FLA/LRA Speeds/CFM Cap. MFD/Volts	COND.												
	EVAP.												
Compressor: FLA/LRA Run Cap. MFD./Volts Acc. Start Kit	Copeland (Recip)												
	11.2 / 61												
Service Driers: Liquid/Charge Suction	8 cu in / 7oz												
	30 sq in												
Ref. Charge (R-22 Oz.)	64												
Clearances See Installation Instructions													
		Heating Performance Data					Blower Performance Data (Add 0.05 In. W.C. for wet coil)						
		Gas Type					230V – Dry Coil						
		Nat					TAP LOW MED L MED H HIGH						
		Input (MBTUH)					.10 – – – –						
		60					.20 620 725 825 995						
		Output (MBTUH)					.30 605 705 805 960						
		47					.40 585 675 775 925						
		Gas Valve (HSP)					.50 565 650 745 880						
		HW					.60 530 615 705 835						
		Regulation Type					.70 485 570 660 780						
		Snap					208V – Dry Coil						
		Manifold Pressure					TAP LOW MED L MED H HIGH						
		3.5					.10 – – – –						
		Orifices					.20 535 620 725 890						
		44					.30 520 600 700 860						
		Pilot Orifice Size					.40 500 580 670 830						
		.018					.50 475 550 635 790						
		Temp. Rise 0F					.60 435 515 600 750						
		45–75					.70 385 470 555 705						
		Ignition Type											
		HSP											
		Fan Control (ON/OFF)											
		TIME											
		Limit Control (MAX)											
		150											
		Heat Anticipator											
		.58											

Note: Optimum operating charge will produce 15° – 25° F suction line superheat at compressor with 82° F outdoor ambient and 80° F Dry Bulb (67° F Wet Bulb) indoor temperature at rated airflow.

1067911
9-22-94
AH-1

Model or Style No. PGAA24D1K		Performance Data: 80° D.B. Indoor											
Specifications		Coil – Internal Rated 800 CFM .15 ESP Wet.											
		Low Wet Bulb (63°)					High Wet Bulb (69°)						
		Amb. Outd	Appx. MBTUH	Sens. Total Ratio	PSIG. Disch. (Head)	PSIG. Suct.	Unit Amp.	Amb. Outd	Appx. MBTUH	Sens. Total Ratio	PSIG. Disch. (Head)	PSIG. Suct.	Unit Amp.
Electrical: Voltage/Phase/Hz Branch Circuit Ampacity Wire Size/Max. Ft. Time Delay Fuse Size Max. Fuse/HACR Brk. Boost Transformer	208/230–1–60	65	24.8	.86	180	64	9.8	65	27.1	.60	194	73	10.3
	17.0	75	24.2	.88	201	68	10.5	75	26.5	.62	217	77	11.0
	No. 12 / 50'	85	23.8	.90	229	71	11.2	85	26.1	.64	247	81	11.8
	20	95	23.2	.92	261	74	11.8	95	25.4	.65	281	85	12.5
	25	105	22.1	.93	293	77	12.5	105	24.2	.66	316	88	13.2
---	---	115	20.2	.93	323	80	13.2	115	22.1	.66	349	92	13.9
Fan Motor: H.P./Type FLA/LRA Speeds/CFM Cap. MFD/Volts	COND.												
	EVAP.												
Compressor: FLA/LRA Run Cap. MFD./Volts Acc. Start Kit	Copeland (Recip)												
	11.2 / 61												
Service Driers: Liquid/Charge Suction	8 cu in / 7oz												
	30 sq in												
Ref. Charge (R-22 Oz.)	64												
Clearances See Installation Instructions													
		Heating Performance Data					Blower Performance Data (Add 0.05 In. W.C. for wet coil)						
		Gas Type					230V – Dry Coil						
		Nat					TAP LOW MED L MED H HIGH						
		Input (MBTUH)					.10 – – – –						
		90/75					.20 790 – – 955 1175						
		Output (MBTUH)					.30 760 – – 915 1120						
		70/59					.40 730 – – 870 1055						
		Gas Valve (HSP)					.50 690 – – 815 990						
		HW					.60 645 – – 755 920						
		Regulation Type					.70 585 – – 685 840						
		Snap					208V – Dry Coil						
		Manifold Pressure					TAP LOW MED L MED H HIGH						
		3.5					.10 – – – –						
		Orifices					.20 670 – – 825 1090						
		43/46					.30 645 – – 790 1040						
		Pilot Orifice Size					.40 620 – – 750 985						
		.018					.50 585 – – 705 925						
		Temp. Rise 0F					.60 540 – – 650 855						
		45–75					.70 485 – – 580 780						
		Ignition Type											
		HSP											
		Fan Control (ON/OFF)											
		TIME											
		Limit Control (MAX)											
		135											
		Heat Anticipator											
		.58											

Note: Optimum operating charge will produce 15° – 25° F suction line superheat at compressor with 82° F outdoor ambient and 80° F Dry Bulb (67° F Wet Bulb) indoor temperature at rated airflow.

1067912
9-22-94
AH-1

Technical Service Data Sheets 1067913 & 1067914

Model or Style No. PGAA30C1K		Performance Data: 80° D.B. Indoor											
Specifications		Coil – Internal Rated 1000 CFM .40 ESP Wet.											
		Low Wet Bulb (63°)					High Wet Bulb (69°)						
		Amb. Outd.	Appx. MBTUH	Sens. Total Ratio	PSIG. Disch. (Head)	PSIG. Suct.	Unit Amp.	Amb. Outd.	Appx. MBTUH	Sens. Total Ratio	PSIG. Disch. (Head)	PSIG. Suct.	Unit Amp.
Electrical: Voltage/Phase/Hz Branch Circuit Ampacity Wire Size/Max. Ft. Time Delay Fuse Size Max. Fuse/HACR Brk. Boost Transformer	208/230–1–60 21.6 30 35 –	65	30.8	.86	169	63	12.0	65	33.7	.60	183	72	12.7
		75	30.1	.88	190	66	12.9	75	33.0	.62	205	76	13.6
		85	29.6	.90	216	70	13.7	85	32.4	.64	233	79	14.5
		95	28.9	.92	245	73	14.6	95	31.6	.65	264	83	15.3
		105	27.5	.93	275	76	15.4	105	30.1	.66	297	87	16.2
Fan Motor: H.P./Type FLA/LRA Speeds/CFM Cap. MFD/ Volts	COND. 1/3 PSC EVAP. 1/3PSC 1.4/3.57 2.3/4.10 1/3000 3/1175 5/370 7.5/370	115	25.1	.93	304	79	16.2	115	27.5	.66	328	90	17.1
		Heating Performance Data					Blower Performance Data (Add 0.05 In. W.C. for Wet Coil)						
		Compressor: FLA/LRA Run Cap. MFD./Volts Acc. Start Kit	Copeland (Recip) 14.4/82 35/370 NAMA001SC	Gas Type Input (MBTUH) Output (MBTUH) Gas Valve (HSP) Regulation Type Manifold Pressure Orifices Pilot Orifice Size Temp. Rise 0F Ignition Type Fan Control (ON/OFF) Limit Control (MAX) Heat Anticipator	Nat 60 47 HW Snap 3.5 44 .018 45–75 HSP TIME 150 .58	External Static Pressure Inches of W. C.	CFM @ 230V – Dry Coil (No Filter)						
							TAP	LOW	MED L	MED H	HIGH		
							.10	–	–	–	–		
.20	790						–	955	1175				
.30	760						–	915	1120				
.40	730	–	870	1055									
.50	690	–	815	990									
.60	645	–	755	920									
.70	585	–	685	840									
CFM @ 208V – Dry Coil (No Filter)													
TAP	LOW	MED L	MED H	HIGH									
.10	–	–	–	–									
.20	670	–	825	1090									
.30	645	–	790	1040									
.40	620	–	750	985									
.50	585	–	705	925									
.60	540	–	650	855									
.70	485	–	580	780									
Service Driers: Liquid/Charge Suction	8 cu in / 7oz 30 sq in	Clearances See Installation Instructions	75	Ref. Charge (R-22 Oz.)	1067913 9–22–94 AH–1								
						Note: Optimum operating charge will produce 15° – 25° F suction line superheat at compressor with 82° F outdoor ambient and 80° F Dry Bulb (67° F Wet Bulb) indoor temperature at rated airflow.							

Model or Style No. PGAA30D1K		Performance Data: 80° D.B. Indoor											
Specifications		Coil – Internal Rated 1000 CFM .40 ESP Wet.											
		Low Wet Bulb (63°)					High Wet Bulb (69°)						
		Amb. Outd.	Appx. MBTUH	Sens. Total Ratio	PSIG. Disch. (Head)	PSIG. Suct.	Unit Amp.	Amb. Outd.	Appx. MBTUH	Sens. Total Ratio	PSIG. Disch. (Head)	PSIG. Suct.	Unit Amp.
Electrical: Voltage/Phase/Hz Branch Circuit Ampacity Wire Size/Max. Ft. Time Delay Fuse Size Max. Fuse/HACR Brk. Boost Transformer	208/230–1–60 21.6 No. 10 / 60' 30 35 –	65	30.8	.86	169	63	12.0	65	33.7	.60	183	72	12.7
		75	30.1	.88	190	66	12.9	75	33.0	.62	205	76	13.6
		85	29.6	.90	216	70	13.7	85	32.4	.64	233	79	14.5
		95	28.9	.92	245	73	14.6	95	31.6	.65	264	83	15.3
		105	27.5	.93	275	76	15.4	105	30.1	.66	297	87	16.2
Fan Motor: H.P./Type FLA/LRA Speeds/CFM Cap. MFD/ Volts	COND. 1/3 PSC EVAP. 1/3PSC 1.4/3.57 2.3/4.10 1/3000 3/1175 5/370 7.5/370	115	25.1	.93	304	79	16.2	115	27.5	.66	328	90	17.1
		Heating Performance Data					Blower Performance Data (Add 0.05 In. W.C. for Wet Coil)						
		Compressor: FLA/LRA Run Cap. MFD./Volts Acc. Start Kit	Copeland (Recip) 14.4/82 35/370 NAMA001SC	Gas Type Input (MBTUH) Output (MBTUH) Gas Valve (HSP) Regulation Type Manifold Pressure Orifices Pilot Orifice Size Temp. Rise 0F Ignition Type Fan Control (ON/OFF) Limit Control (MAX) Heat Anticipator	Nat 90/75 70/59 HW Snap 3.5 43/46 .018 45–75 HSP TIME 135 .58	External Static Pressure Inches of W. C.	CFM @ 230V – Dry Coil (No Filter)						
							TAP	LOW	MED L	MED H	HIGH		
							.10	–	–	–	–		
.20	790						–	955	1175				
.30	760						–	915	1120				
.40	730	–	870	1055									
.50	690	–	815	990									
.60	645	–	755	920									
.70	585	–	685	840									
CFM @ 208V – Dry Coil (No Filter)													
TAP	LOW	MED L	MED H	HIGH									
.10	–	–	–	–									
.20	670	–	825	1090									
.30	645	–	790	1040									
.40	620	–	750	985									
.50	585	–	705	925									
.60	540	–	650	855									
.70	485	–	580	780									
Service Driers: Liquid/Charge Suction	8 cu in / 7oz 30 sq in	Clearances See Installation Instructions	75	Ref. Charge (R-22 Oz.)	1067914 9–22–94 AH–1								
						Note: Optimum operating charge will produce 15° – 25° F suction line superheat at compressor with 82° F outdoor ambient and 80° F Dry Bulb (67° F Wet Bulb) indoor temperature at rated airflow.							

Technical Service Data Sheets 1067920 & 1067921

Table for PGAD24B1K model. Columns include Voltage, Phase, Ampacity, Wire Ga/Ft, Delay Fuse, Max. Fuse, Compressor (COPELAND), RLA, LRA, Cap MFD/V, CC Heater, Start Kit (NAMA001SC), Cond & Evap (Fan/Blower), Type, Size, Motor-HP, Type, FLA, LRA, RPM, Cap MFD/V, PTCR, Hi Press, Low Press, Operating Chg (R-22 Oz), Service Driers, Liquid/Chg (8 Cu In / 7 oz), Suction (30 Sq In), Unit Weight (410). Rows include Gas Type, NAT, IDB, Outdoor Ambient Temperature (75, 85, 95, 105, 115), Entering Indoor Temperature, and various pressure/flow data points (MBh, S/T, AMPS, HI PR, LO PR).

Table for PGAD24D1K model. Columns include Voltage, Phase, Ampacity, Wire Ga/Ft, Delay Fuse, Max. Fuse, Compressor (COPELAND), RLA, LRA, Cap MFD/V, CC Heater, Start Kit (NAMA001SC), Cond & Evap (Fan/Blower), Type, Size, Motor-HP, Type, FLA, LRA, RPM, Cap MFD/V, PTCR, Hi Press, Low Press, Operating Chg (R-22 Oz), Service Driers, Liquid/Chg (8 Cu In / 7 oz), Suction (30 Sq In), Unit Weight (410). Rows include Gas Type, NAT, IDB, Outdoor Ambient Temperature (75, 85, 95, 105, 115), Entering Indoor Temperature, and various pressure/flow data points (MBh, S/T, AMPS, HI PR, LO PR).

Technical Service Data Sheets 1067922 & 1067923

Style No:		PGAD30D1K		Outdoor Ambient Temperature - Degrees F. Dry Bulb																																			
Voltage		208 / 230		Gas Type		NAT		75				85				95				105				115															
Phase		1		Std Input		90		Entering Indoor Temperature - Degrees F. Wet Bulb																															
Ampacity		20.5		Low Fire Input		75		59				63				67				71				59				63				67				71			
Wire Ga/Ft		12 / 40		Std Output		69		IDB																															
Delay Fuse		25		Low Fire Output		59		70																															
Max. Fuse		30		Gas Valve (HSP)		HW		75																															
Compressor		COPELAND		Regulation		SNAP		80																															
RLA		13.5		Manifold Press		3.5		85																															
LRA		76		Std orifice		43		88																															
Cap MFD/V		35 / 370		Low Fire Orifice		46		91																															
CC Heater				Pilot Orifice		0.018		94																															
Start Kit		NAMA001SC		Temp Rise		45-75		97																															
Cond & Evap		Cond		Evap		Ignition Type		100																															
Type		Fan		Blower		Fan On/Off		103																															
Size		20		DD10-8A		Limit Set Max		106																															
Motor-HP		1/3		1/3		Heat Antic		109																															
Type		PSC		PSC				112																															
FLA		1.4		2.3				115																															
LRA		3.57		4.1				118																															
RPM		1135		1100				121																															
Cap MFD/V		5/370		5/370				124																															
PTCR								127																															
Hi Press								130																															
Low Press								133																															
Operating Chg (No Lines)*		(R-22 Oz)						136																															
Service Driers								139																															
Liquid/Chg		8 Cu In / 7 oz						142																															
Suction		30 Sq In						145																															
Unit Weight		425						148																															
								Air Delivery in CFM - Dry Coil - No Filter (Add .05 static for Wet Coil)																															
				230 Volt External Static Press (Inch Water Column)												208 Volt External Static Press (Inch Water Column)																							
Speed Tap		0.1		0.2		0.3		0.4		0.5		0.6		0.7		Speed Tap		0.1		0.2		0.3		0.4		0.5		0.6		0.7									
HI		-		1175		1120		1055		990		920		840		HI		-		1090		1040		985		925		855		780									
MD HI		-		955		915		870		815		755		695		MD HI		-		825		790		750		705		650		580									
MD LO		-		-		-		-		-		-		-		MD LO		-		-		-		-		-		-		-									
LO		-		790		760		730		690		645		585		LO		-		670		645		620		585		540		485									

Style No:		PGAD36D1K		Outdoor Ambient Temperature - Degrees F. Dry Bulb																																			
Voltage		208 / 230		Gas Type		NAT		75				85				95				105				115															
Phase		1		Std Input		90		Entering Indoor Temperature - Degrees F. Wet Bulb																															
Ampacity		27.4		Low Fire Input		75		59				63				67				71				59				63				67				71			
Wire Ga/Ft		10 / 50		Std Output		70		IDB																															
Delay Fuse		35		Low Fire Output		59		70																															
Max. Fuse		45		Gas Valve (HSP)		HW		75																															
Compressor		COPELAND		Regulation		SNAP		80																															
RLA		17.9		Manifold Press		3.5		85																															
LRA		90.5		Std orifice		43		88																															
Cap MFD/V		35 / 440		Low Fire Orifice		46		91																															
CC Heater				Pilot Orifice		0.018		94																															
Start Kit		NAMA001SC		Temp Rise		45-75		97																															
Cond & Evap		Cond		Evap		Ignition Type		100																															
Type		Fan		Blower		Fan On/Off		103																															
Size		20		DD11-9A		Limit Set Max		106																															
Motor-HP		1/3		1/2		Heat Antic		109																															
Type		PSC		PSC				112																															
FLA		1.4		3.6				115																															
LRA		3.57		7.5				118																															
RPM		1135		1125				121																															
Cap MFD/V		5/370		15/370				124																															
PTCR								127																															
Hi Press								130																															
Low Press								133																															
Operating Chg (No Lines)*		(R-22 Oz)						136																															
Service Driers								139																															
Liquid/Chg		16 Cu In / 11 oz						142																															
Suction		30 Sq In						145																															
Unit Weight		435						148																															
								Air Delivery in CFM - Dry Coil - No Filter (Add .05 static for Wet Coil)																															
				230 Volt External Static Press (Inch Water Column)												208 Volt External Static Press (Inch Water Column)																							
Speed Tap		0.1		0.2		0.3		0.4		0.5		0.6		0.7		Speed Tap		0.1		0.2		0.3		0.4		0.5		0.6		0.7									
HI		-		1435		1375		1310		1245		1175		1105		HI		-		1345		1295		1240		1180		1115		1050									
MD HI		-		1270		1220		1165		1100		1045		990		MD HI		-		1095		1065		1030		990		945		895									
MD LO		-		-		-		-		-		-		-		MD LO		-		-		-		-		-		-		-									
LO		-		1110		1080		1045		1005		955		905		LO		-		925		905		880		850		815		780									

Technical Service Data Sheets 1067924 & 1067927

Style No:	PGAD36E1K		Outdoor Ambient Temperature - Degrees F. Dry Bulb																									
			75					85					95					105					115					
			Entering Indoor Temperature - Degrees F. Wet Bulb																									
Voltage	208 / 230		Gas Type	NAT	IDB	59	63	67	71	59	63	67	71	59	63	67	71	59	63	67	71	59	63	67	71			
Phase	1		Std Input	115		MBh	33.1	34.3	37.6	-	32.3	33.5	36.7	-	31.5	32.7	35.8	-	29.9	31.0	34.0	-	27.7	28.7	31.5	-		
Ampacity	27.4		Low Fire Input	95	S/T	0.73	0.61	0.43	-	0.75	0.63	0.44	-	0.78	0.65	0.45	-	0.81	0.67	0.47	-	0.81	0.68	0.47	-			
Wire Ga/Ft	10 / 50		Std Output	90	AMPS	11.8	12.1	12.5	-	12.8	13.1	13.5	-	13.7	14.0	14.4	-	14.5	14.9	15.3	-	15.4	15.7	16.2	-			
Delay Fuse	35		Low Fire Output	75	HI PR	184	198	209	-	209	225	237	-	238	256	270	-	268	288	304	-	296	318	336	-			
Max. Fuse	45		Gas Valve (HSP)	HW	LO PR	64	68	75	-	67	71	77	-	70	75	81	-	73	78	85	-	76	81	88	-			
Compressor	COPELAND		Regulation	SNAP	70	MBh	33.6	34.6	37.5	40.2	32.8	33.8	36.6	39.3	32.0	33.0	35.7	38.3	30.4	31.3	33.9	36.4	28.2	29.0	31.4	33.7		
RLA	17.9		Manifold Press	3.5		S/T	0.84	0.75	0.57	0.36	0.86	0.77	0.58	0.37	0.88	0.79	0.60	0.38	0.92	0.82	0.62	0.40	0.93	0.83	0.63	0.40		
LRA	90.5		Std orifice	43		AMPS	11.9	12.2	12.6	13.0	12.9	13.2	13.6	14.1	13.8	14.1	14.6	15.1	14.6	15.0	15.5	16.1	15.5	15.9	16.4	17.0		
Cap MFD/V	35 / 440		Low Fire Orifice	46	HI PR	186	200	211	220	211	227	240	250	240	259	273	285	271	291	307	321	299	322	340	354			
CC Heater			Pilot Orifice	0.018	LO PR	65	69	75	80	67	72	78	83	71	75	82	88	74	79	86	92	77	82	89	95			
Start Kit	NAMA001SC		Temp Rise	45-75	75	MBh	34.2	35.0	37.4	40.0	33.4	34.2	36.5	39.0	32.6	33.3	35.6	38.1	31.0	31.7	33.8	36.2	28.7	29.3	31.3	33.5		
Cond & Evap	Cond	Evap	Ignition Type	HSP		S/T	0.92	0.86	0.70	0.52	0.94	0.88	0.72	0.54	0.97	0.91	0.74	0.55	1.00	0.94	0.77	0.57	1.00	0.95	0.77	0.58		
Type	Fan	Blower	Fan On/Off	TIME		AMPS	12.0	12.3	12.7	13.2	13.0	13.3	13.8	14.3	13.9	14.2	14.7	15.2	14.8	15.1	15.6	16.2	15.6	16.0	16.5	17.2		
Motor-HP	1/3	1/2	Limit Set Max	140	HI PR	188	202	213	222	213	229	242	253	243	261	276	288	273	294	311	324	302	325	343	358			
Type	PSC	PSC	Heat Antic	0.58	LO PR	65	70	76	81	68	72	79	84	71	76	83	88	75	80	87	93	77	82	90	96			
FLA	1.4	3.6			80	MBh	34.8	35.5	37.2	39.7	34.0	34.7	36.3	38.7	33.2	33.8	35.4	37.8	31.5	32.1	33.7	35.9	29.2	29.8	31.2	33.3		
LRA	3.57	7.5				S/T	0.96	0.93	0.84	0.68	0.98	0.95	0.86	0.70	1.00	0.98	0.89	0.72	1.00	0.92	0.89	0.72	1.00	0.92	0.89	0.75		
RPM	1135	1145				AMPS	12.1	12.4	12.8	13.3	13.1	13.5	13.9	14.4	14.0	14.4	14.8	15.4	14.9	15.3	15.8	16.4	15.8	16.2	16.7	17.3		
Cap MFD/V	5/370	15/370			85	HI PR	189	204	215	224	215	232	245	255	245	264	279	291	276	297	314	327	305	328	346	361		
PTCR								LO PR	66	70	77	82	69	73	80	85	72	77	84	89	76	80	88	94	78	83	91	97
Hi Press								Air Delivery in CFM - Dry Coil - No Filter (Add .05 static for Wet Coil)																				
Low Press																												
Operating Chg (No Lines)*	(R-22 Oz) 78																											
Service Driers																												
Liquid/Chg Suction	16 Cu In / 11 oz 30 Sq In																											
Unit Weight	435																											

Model or Style No. PGAA36C1K		Performance Data: 80° D.B. Indoor											
Specifications		Coil - Internal Rated 1200 CFM .20 ESP Wet.											
Electrical: Voltage/Phase/Hz Branch Circuit Ampacity Wire Size/Max. Ft. Time Delay Fuse Size Max. Fuse/HACR Brk. Boost Transformer	208/230-1-60 29.3 No. 10 / 58' 35 45 - - - -	Low Wet Bulb (63°)					High Wet Bulb (69°)						
		Amb. Outd	Appx. MBTUH	Sens. Total Ratio	PSIG. Disch. (Head)	PSIG. Suct.	Unit Amp	Amb. Outd	Appx. MBTUH	Sens. Total Ratio	PSIG. Disch. (Head)	PSIG. Suct.	Unit Amp
		65	34.2	.88	169	65	14.1	65	37.4	.62	183	74	14.9
		75	33.5	.90	190	69	15.1	75	36.6	.64	205	79	15.9
		85	32.9	.92	216	72	16.1	85	36.0	.66	233	82	17.0
		95	32.1	.94	245	76	17.1	95	35.1	.67	264	86	18.0
105	30.5	.95	275	79	18.0	105	33.4	.68	297	90	19.0		
115	27.9	.95	304	82	19.0	115	30.6	.68	328	93	20.0		
Fan Motor: H.P./Type FLA/LRA Speeds/CFM Cap. MFD/Volts	COND. 1/2 EVAP. 1/3 PSC PSC 1.4/3.57 3.6/7.5 1/3000 3/1435 5/370 15/370	Blower Performance Data (Add 0.05 in. W. C. for wet coil)											
Compressor: FLA/LRA Run Cap. MFD./Volts Acc. Start Kit	Copeland (Recip) 19.5 / 82.0 35/440 NAMA001SC	Heating Performance Data					External Static Pressure Inches of W. C.						
Service Driers: Liquid/Charge Suction	16 cu in / 11oz 30 sq in	Gas Type Input (MBTUH) Output (MBTUH) Gas Valve (HSP) Regulation Type Manifold Pressure Orifices Pilot Orifice Size Temp. Rise OF Ignition Type Fan Control (ON/OFF) Limit Control (MAX) Heat Anticipator	Nat 60 47 HW Snap 3.5 44 .018 30-60 HSP TIME 150 .58	CFM @ 230V - Dry Coil (No Filter) TAP LOW MED L MED H HIGH .10 - - - - .20 1110 - - 1270 1435 .30 1080 - - 1220 1375 .40 1045 - - 1165 1310 .50 1005 - - 1100 1245 .60 955 - - 1045 1175 .70 905 - - 990 1105 CFM @ 208V - Dry Coil (No Filter) TAP LOW MED L MED H HIGH .10 - - - - .20 925 - - 1095 1345 .30 905 - - 1065 1295 .40 880 - - 1030 1240 .50 850 - - 990 1180 .60 815 - - 945 1115 .70 780 - - 895 1050									
Ref. Charge (R-22 Oz.)	81	Note: Optimum operating charge will produce 15° - 25° F suction line superheat at compressor with 82° F outdoor ambient and 80° F Dry Bulb (67° F Wet Bulb) indoor temperature at rated airflow.											
Clearances See Installation Instructions		1067927 9-22-94 AH-1											

Technical Service Data Sheets 1067928 & 1067929

Model or Style No. PGAA36D1K		Performance Data: 80° D.B. Indoor											
Specifications		Coil – Internal Rated 1200 CFM .20 ESP Wet.											
Electrical: Voltage/Phase/Hz Branch Circuit Ampacity Wire Size/Max. Ft. Time Delay Fuse Size Max. Fuse/HACR Brk. Boost Transformer		Low Wet Bulb (63°)					High Wet Bulb (69°)						
		Amb. Outd.	Appx. MBTUH	Sens. Total Ratio	PSIG. Disch. (Head)	PSIG. Suct.	Unit Amp.	Amb. Outd.	Appx. MBTUH	Sens. Total Ratio	PSIG. Disch. (Head)	PSIG. Suct.	Unit Amp.
208/230–1–60 29.3 No. 10 / 58' 35 45 – – – –		65	34.2	.88	169	65	14.1	65	37.4	.62	183	74	14.9
Fan Motor: COND. EVAP. H.P./Type 1/3 PSC 1/2 FLA/LRA 1.4/3.57 PSC Speeds/CFM 1/3000 3.6/7.5 Cap. MFD/Volts 5/370 3/1435 15/370		75	33.5	.90	190	69	15.1	75	36.6	.64	205	79	15.9
Compressor: Copeland (Recip) FLA/LRA 19.5 / 82.0 Run Cap. MFD./Volts 35/440 Acc. Start Kit NAMA001SC		85	32.9	.92	216	72	16.1	85	36.0	.66	233	82	17.0
Service Driers: Liquid/Charge Suction 16 cu in / 11oz 30 sq in		95	32.1	.94	245	76	17.1	95	35.1	.67	264	86	18.0
Ref. Charge (R-22 Oz.) 81		105	30.5	.95	275	79	18.0	105	33.4	.68	297	90	19.0
Clearances See Installation Instructions		115	27.9	.95	304	82	19.0	115	30.6	.68	328	93	20.0
		Heating Performance Data					Blower Performance Data (Add 0.05 In. W. C. for wet coil)						
		Gas Type		Nat		External Static Pressure							
		Input (MBTUH)		90/75		Inches of W. C.							
		Output (MBTUH)		70/59									
		Gas Valve (HSP)		HW									
		Regulation Type		Snap									
		Manifold Pressure		3.5									
		Orifices		43/46									
		Pilot Orifice Size		.018									
		Temp. Rise 0F		45–75									
		Ignition Type		HSP									
		Fan Control (ON/OFF)		TIME									
		Limit Control (MAX)		135									
		Heat Anticipator		.58									
		CFM @ 230V – Dry Coil (No Filter)											
		TAP	LOW	MED L	MED H	HIGH							
		.10	–	–	–	–							
		.20	1110	–	1270	1435							
		.30	1080	–	1220	1375							
		.40	1045	–	1165	1310							
		.50	1005	–	1100	1245							
		.60	955	–	1045	1175							
		.70	905	–	990	1105							
		CFM @ 208V – Dry Coil (No Filter)											
		TAP	LOW	MED L	MED H	HIGH							
		.10	–	–	–	–							
		.20	925	–	1095	1345							
		.30	905	–	1065	1295							
		.40	880	–	1030	1240							
		.50	850	–	990	1180							
		.60	815	–	945	1115							
		.70	780	–	895	1050							

Note: Optimum operating charge will produce 15° – 25° F suction line superheat at compressor with 82° F outdoor ambient and 80° F Dry Bulb (67° F Wet Bulb) indoor temperature at rated airflow.

1067928
9–22–94
AH–1

Model or Style No. PGAA36E1K		Performance Data: 80° D.B. Indoor											
Specifications		Coil – Internal Rated 1200 CFM .20 ESP Wet.											
Electrical: Voltage/Phase/Hz Branch Circuit Ampacity Wire Size/Max. Ft. Time Delay Fuse Size Max. Fuse/HACR Brk. Boost Transformer		Low Wet Bulb (63°)					High Wet Bulb (69°)						
		Amb. Outd.	Appx. MBTUH	Sens. Total Ratio	PSIG. Disch. (Head)	PSIG. Suct.	Unit Amp.	Amb. Outd.	Appx. MBTUH	Sens. Total Ratio	PSIG. Disch. (Head)	PSIG. Suct.	Unit Amp.
208/230–1–60 31.3 No. 8 / 91' 40 50 – – – –		65	34.2	.88	169	65	14.1	65	37.4	.62	183	74	14.9
Fan Motor: COND. EVAP. H.P./Type 1/3 PSC 1/2 FLA/LRA 1.4/5.8 PSC Speeds/CFM 1/3000 5.6/8.9 Cap. MFD/Volts 5/370 4/1645 15/370		75	33.5	.90	190	69	15.1	75	36.6	.64	205	79	15.9
Compressor: Copeland (Recip) FLA/LRA 19.5 / 82.0 Run Cap. MFD./Volts 35/440 Acc. Start Kit NAMA001SC		85	32.9	.92	216	72	16.1	85	36.0	.66	233	82	17.0
Service Driers: Liquid/Charge Suction 16 cu in / 11oz 30 sq in		95	32.1	.94	245	76	17.1	95	35.1	.67	264	86	18.0
Ref. Charge (R-22 Oz.) 81		105	30.5	.95	275	79	18.0	105	33.4	.68	297	90	19.0
Clearances See Installation Instructions		115	27.9	.95	304	82	19.0	115	30.6	.68	328	93	20.0
		Heating Performance Data					Blower Performance Data (Add 0.05 In. W. C. for wet coil)						
		Gas Type		Nat		External Static Pressure							
		Input (MBTUH)		115/90		Inches of W. C.							
		Output (MBTUH)		95/75									
		Gas Valve (HSP)		HW									
		Regulation Type		Snap									
		Manifold Pressure		3.5									
		Orifices		43/46									
		Pilot Orifice Size		.018									
		Temp. Rise 0F		45–75									
		Ignition Type		HSP									
		Fan Control (ON/OFF)		TIME									
		Limit Control (MAX)		135									
		Heat Anticipator		.58									
		CFM @ 230V – Dry Coil (No Filter)											
		TAP	LOW	MED L	MED H	HIGH							
		.10	–	–	–	–							
		.20	1070	–	1295	1490							
		.30	1055	–	1270	1440							
		.40	1040	–	1235	1385							
		.50	1020	–	1195	1330							
		.60	990	–	1145	1270							
		.70	955	–	1095	1210							
		CFM @ 208V – Dry Coil (No Filter)											
		TAP	LOW	MED L	MED H	HIGH							
		.10	–	–	–	–							
		.20	870	–	1090	1330							
		.30	860	–	1080	1300							
		.40	850	–	1055	1260							
		.50	840	–	1030	1220							
		.60	825	–	1000	1170							
		.70	805	–	960	1120							

Note: Optimum operating charge will produce 15° – 25° F suction line superheat at compressor with 82° F outdoor ambient and 80° F Dry Bulb (67° F Wet Bulb) indoor temperature at rated airflow.

1067929
9–22–94
AH–1

Technical Service Data Sheets 1067935 & 1067936

Model or Style No. PGAA42C1K		Performance Data: 80° D.B. Indoor											
Specifications		Coil – Internal Rated 1400 CFM .20 ESP Wet.											
Electrical: Voltage/Cycles/Phase Branch Circuit Ampacity Wire Size/Max. Ft. Time Delay Fuse Size Max. Fuse/HACR Brk. Boost Transformer		Low Wet Bulb (63°)					High Wet Bulb (69°)						
		Amb. Outd.	Appx. MBTUH	Sens. Total Ratio	PSIG. Disch. (Head)	PSIG. Suct.	Unit Amp.	Amb. Outd.	Appx. MBTUH	Sens. Total Ratio	PSIG. Disch. (Head)	PSIG. Suct.	Unit Amp.
208/230–1–60 31.8 No. 8 / 70' 40 50 – – – –		65	40.3	.87	188	64	17.2	65	44.1	.61	203	72	18.1
		75	39.4	.89	210	67	18.4	75	43.1	.63	227	76	19.4
		85	38.7	.91	239	70	19.6	85	42.4	.65	258	80	20.6
		95	37.7	.93	271	74	20.8	95	41.3	.66	293	84	21.9
		105	35.9	.94	305	77	21.9	105	39.3	.67	329	87	23.1
		115	32.9	.94	336	80	23.1	115	36.0	.67	363	91	24.3
Fan Motor:		COND. EVAP.		Blower Performance Data (Add 0.05 In. W.C. for wet coil)									
H.P./Type FLA/LRA Run Cap. MFD./Volts Speeds/CFM Cap. MFD/Volts		1/3 PSC 3/4 PSC 1.4/13.57 5.6/12.8 1/3000 4/1645 5/370 15/370		Heating Performance Data					External Static Pressure				
Compressor: FLA/LRA Run Cap. MFD./Volts Acc. Start Kit		Copeland (Scroll) 19.9 / 107 35/440 NAMA001SC		Gas Type	Nat		External Static Pressure	Inches of W. C.					
Service Driers: Liquid/Charge Suction		16 cu in / 11oz 30 sq in		Input (MBTUH)	60			CFM @ 230V – Dry Coil (No filter)					
				Output (MBTUH)	47			TAP	LOW	MED L	MED H	HIGH	
				Gas Valve (HSP)	HW			.10	–	–	–	–	
				Regulation Type	Snap			.20	1070	1295	1490	1645	
				Manifold Pressure	3.5			.30	1055	1270	1440	1580	
				Orifices	44			.40	1040	1235	1385	1515	
				Pilot Orifice Size	.018			.50	1020	1195	1330	1450	
				Temp. Rise OF	30–60			.60	990	1145	1270	1385	
				Ignition Type	HSP			.70	955	1095	1210	1315	
Ref. Charge (R-22 Oz.)		82		Fan Control (ON/OFF)	TIME		CFM @ 208V – Dry Coil (No filter)						
Clearances See Installation Instructions				Limit Control (MAX)	160		TAP	LOW	MED L	MED H	HIGH		
				Heat Anticipator	.58		.10	–	–	–	–		
								.20	870	1090	1330	1585	
								.30	860	1080	1300	1530	
								.40	850	1055	1260	1480	
								.50	840	1030	1220	1425	
								.60	825	1000	1170	1365	
								.70	805	960	1120	1300	

Note: Optimum operating charge will produce 15° – 25° F suction line superheat at compressor with 82° F outdoor ambient and 80° F Dry Bulb (67° F Wet Bulb) indoor temperature at rated airflow.

1067935
9–22–94
AH-1

Model or Style No. PGAA42E1K		Performance Data: 80° D.B. Indoor											
Specifications		Coil – Internal Rated 1400 CFM .20 ESP Wet.											
Electrical: Voltage/Cycles/Phase Branch Circuit Ampacity Wire Size/Max. Ft. Time Delay Fuse Size Max. Fuse/HACR Brk. Boost Transformer		Low Wet Bulb (63°)					High Wet Bulb (69°)						
		Amb. Outd.	Appx. MBTUH	Sens. Total Ratio	PSIG. Disch. (Head)	PSIG. Suct.	Unit Amp.	Amb. Outd.	Appx. MBTUH	Sens. Total Ratio	PSIG. Disch. (Head)	PSIG. Suct.	Unit Amp.
208/230–1–60 31.8 No. 8 / 70' 40 50 – – – –		65	40.3	.87	188	64	17.2	65	44.1	.61	203	72	18.1
		75	39.4	.89	210	67	18.4	75	43.1	.63	227	76	19.4
		85	38.7	.91	239	70	19.6	85	42.4	.65	258	80	20.6
		95	37.7	.93	271	74	20.8	95	41.3	.66	293	84	21.9
		105	35.9	.94	305	77	21.9	105	39.3	.67	329	87	23.1
		115	32.9	.94	336	80	23.1	115	36.0	.67	363	91	24.3
Fan Motor:		COND. EVAP.		Blower Performance Data (Add 0.05 In. W.C. for wet coil)									
H.P./Type FLA/LRA Run Cap. MFD./Volts Speeds/CFM Cap. MFD/Volts		1/3 PSC 3/4 PSC 1.4/13.57 5.6/12.8 1/3000 4/1645 5/370 15/370		Heating Performance Data					External Static Pressure				
Compressor: FLA/LRA Run Cap. MFD./Volts Acc. Start Kit		Copeland (Scroll) 19.9 / 107 35/440 NAMA001SC		Gas Type	Nat		External Static Pressure	Inches of W. C.					
Service Driers: Liquid/Charge Suction		16 cu in / 11oz 30 sq in		Input (MBTUH)	115/95			CFM @ 230V – Dry Coil (No filter)					
				Output (MBTUH)	90/75			TAP	LOW	MED L	MED H	HIGH	
				Gas Valve (HSP)	HW			.10	–	–	–	–	
				Regulation Type	Snap			.20	1070	1295	1490	1645	
				Manifold Pressure	3.5			.30	1055	1270	1440	1580	
				Orifices	43/46			.40	1040	1235	1385	1515	
				Pilot Orifice Size	.018			.50	1020	1195	1330	1450	
				Temp. Rise OF	45–75			.60	990	1145	1270	1385	
				Ignition Type	HSP			.70	955	1095	1210	1315	
Ref. Charge (R-22 Oz.)		82		Fan Control (ON/OFF)	TIME		CFM @ 208V – Dry Coil (No filter)						
Clearances See Installation Instructions				Limit Control (MAX)	135		TAP	LOW	MED L	MED H	HIGH		
				Heat Anticipator	.58		.10	–	–	–	–		
								.20	870	1090	1330	1585	
								.30	860	1080	1300	1530	
								.40	850	1055	1260	1480	
								.50	840	1030	1220	1425	
								.60	825	1000	1170	1365	
								.70	805	960	1120	1300	

Note: Optimum operating charge will produce 15° – 25° F suction line superheat at compressor with 82° F outdoor ambient and 80° F Dry Bulb (67° F Wet Bulb) indoor temperature at rated airflow.

1067936
9–22–94
AH-1

Technical Service Data Sheets 1067958 & 1067959

Style No:		PGAD42D1K		Outdoor Ambient Temperature - Degrees F. Dry Bulb																																			
Voltage		208 / 230		Gas Type		NAT		75				85				95				105				115															
Phase		1		Std Input		90		Entering Indoor Temperature - Degrees F. Wet Bulb																															
Ampacity		31		Low Fire Input		75		59				63				67				71				59				63				67				71			
Wire Ga/Ft	8 / 72	Std Output		71		IDB	70	MBh	38.6	40.0	43.8	-	37.6	39.0	42.8	-	36.7	38.1	41.7	-	34.9	36.2	39.6	-	32.3	33.5	36.7	-											
Delay Fuse	40	Low Fire Output		60				S/T	0.76	0.64	0.44	-	0.78	0.65	0.45	-	0.81	0.68	0.47	-	0.84	0.70	0.49	-	0.85	0.71	0.49	-											
Max. Fuse	50	Gas Valve (HSP)		HW		70	AMPS	16.1	16.4	16.8	-	17.2	17.5	18.0	-	18.2	18.5	19.0	-	19.1	19.5	20.1	-	20.1	20.5	21.1	-												
Compressor	COPELAND	Regulation		SNAP			HI PR	165	178	188	-	188	202	213	-	214	230	243	-	241	259	273	-	266	286	302	-												
RLA	19.9	Manifold Press		3.5		75	LO PR	66	71	77	-	69	73	80	-	73	77	84	-	76	81	88	-	79	84	91	-												
LRA	107	Std orifice		43			MBh	39.2	40.4	43.7	46.9	38.3	39.4	42.7	45.8	37.4	38.5	41.6	44.7	35.5	36.5	39.5	42.4	32.9	33.8	36.6	39.3												
Cap MFD/V	40 / 440	Low Fire Orifice		46		S/T	0.87	0.78	0.59	0.38	0.89	0.80	0.60	0.39	0.92	0.82	0.62	0.40	0.95	0.85	0.65	0.42	0.96	0.86	0.65	0.42													
CC Heater		Pilot Orifice		0.018		75	AMPS	16.2	16.5	16.9	17.5	17.3	17.7	18.1	18.7	18.3	18.7	19.2	19.8	19.3	19.7	20.2	20.9	20.2	20.6	21.2	21.9												
Start Kit	NAMA001SC	Temp Rise		30 - 60			HI PR	167	179	190	198	190	204	216	225	216	233	246	256	243	262	276	288	269	289	305	318												
Cond & Evap	Cond	Evap	Ignition Type		HSP		LO PR	67	71	78	83	70	74	81	86	73	78	85	91	77	82	89	95	79	85	92	98												
Type	Fan	Blower	Fan On/Off		TIME		80	MBh	39.9	40.8	43.6	46.6	39.0	39.8	42.5	45.5	38.0	38.8	41.5	44.4	36.1	36.9	39.4	42.1	33.5	34.2	36.5	39.0											
Size	22	DD10-9	Limit Set Max		135			S/T	0.95	0.89	0.73	0.54	0.98	0.92	0.75	0.56	1.00	0.95	0.77	0.58	1.00	0.98	0.80	0.60	1.00	0.99	0.81	0.60											
Motor-HP	1/2	1/2	Heat Antic		0.58		80	AMPS	16.3	16.6	17.1	17.6	17.4	17.8	18.3	18.9	18.4	18.8	19.3	19.9	19.4	19.8	20.4	21.0	20.4	20.8	21.4	22.1											
Type	PSC	PSC	HI PR		168			181	191	200	192	206	218	227	218	235	248	259	246	264	279	291	271	292	308	322													
FLA	1.8	4.4	LO PR		68		72	79	84	70	75	82	87	74	79	86	92	78	83	90	96	80	85	93	99														
LRA	6	8.6	85		85	MBh	40.6	41.4	43.4	46.3	39.6	40.4	42.3	45.2	38.7	39.4	41.3	44.1	36.7	37.5	39.2	41.9	34.0	34.7	36.3	38.8													
RPM	1145	1125	S/T			1.00		0.96	0.87	0.71	1.00	0.99	0.89	0.72	1.00	1.00	0.92	0.75	1.00	1.00	0.96	0.78	1.00	1.00	0.96	0.78													
Cap MFD/V	7.5/440	15/370	AMPS		16.4		16.7	17.2	17.7	17.6	17.9	18.4	19.0	18.6	19.0	19.5	20.1	19.6	20.0	20.5	21.2	20.5	21.0	21.6	22.3														
PTCR			HI PR		170		183	193	202	194	208	220	229	220	237	250	261	248	267	282	294	274	295	311	325														
Hi Press			LO PR		69		73	80	85	71	76	83	88	75	80	87	93	78	83	91	97	81	86	94	100														
Low Press			Air Delivery in CFM - Dry Coil - No Filter (Add .05 static for Wet Coil)																																				
Operating Chg (No Lines)*	(R-22 Oz)	180	230 Volt		External Static Press (Inch Water Column)							208 Volt		External Static Press (Inch Water Column)																									
			Speed Tap	0.1	0.2	0.3	0.4	0.5	0.6	0.7	Speed Tap	0.1	0.2	0.3	0.4	0.5	0.6	0.7																					
Service Driers	16 Cu In / 11 oz	Suction	HI		1925	1860	1795	1725	1650	1570	1485	HI		1805	1755	1700	1640	1575	1500	1415																			
			MD HI	1785	1735	1680	1620	1560	1485	1405	MD HI	1610	1580	1540	1495	1440	1375	1300																					
Liqud/Chg	30 Sq In	Unit Weight	MD LO		1570	1540	1505	1465	1415	1380	1280	MD LO		1385	1355	1330	1300	1265	1215	1155																			
			LO	1485	1460	1430	1395	1345	1290	1225	LO	1270	1265	1250	1225	1190	1140	1085																					

Style No:		PGAD42E1K		Outdoor Ambient Temperature - Degrees F. Dry Bulb																																			
Voltage		208 / 230		Gas Type		NAT		75				85				95				105				115															
Phase		1		Std Input		115		Entering Indoor Temperature - Degrees F. Wet Bulb																															
Ampacity		31		Low Fire Input		95 <th colspan="4">59</th> <th colspan="4">63</th> <th colspan="4">67</th> <th colspan="4">71</th> <th colspan="4">59</th> <th colspan="4">63</th> <th colspan="4">67</th> <th colspan="4">71</th>		59				63				67				71				59				63				67				71			
Wire Ga/Ft	8 / 72	Std Output		90		IDB	70	MBh	38.6	40.0	43.8	-	37.6	39.0	42.8	-	36.7	38.1	41.7	-	34.9	36.2	39.6	-	32.3	33.5	36.7	-											
Delay Fuse	40	Low Fire Output		75				S/T	0.76	0.64	0.44	-	0.78	0.65	0.45	-	0.81	0.68	0.47	-	0.84	0.70	0.49	-	0.85	0.71	0.49	-											
Max. Fuse	50	Gas Valve (HSP)		HW		70	AMPS	16.1	16.4	16.8	-	17.2	17.5	18.0	-	18.2	18.5	19.0	-	19.1	19.5	20.1	-	20.1	20.5	21.1	-												
Compressor	COPELAND	Regulation		SNAP			HI PR	165	178	188	-	188	202	213	-	214	230	243	-	241	259	273	-	266	286	302	-												
RLA	19.9	Manifold Press		3.5		75	LO PR	66	71	77	-	69	73	80	-	73	77	84	-	76	81	88	-	79	84	91	-												
LRA	107	Std orifice		43			MBh	39.2	40.4	43.7	46.9	38.3	39.4	42.7	45.8	37.4	38.5	41.6	44.7	35.5	36.5	39.5	42.4	32.9	33.8	36.6	39.3												
Cap MFD/V	40 / 440	Low Fire Orifice		46		S/T	0.87	0.78	0.59	0.38	0.89	0.80	0.60	0.39	0.92	0.82	0.62	0.40	0.95	0.85	0.65	0.42	0.96	0.86	0.65	0.42													
CC Heater		Pilot Orifice		0.018		75	AMPS	16.2	16.5	16.9	17.5	17.3	17.7	18.1	18.7	18.3	18.7	19.2	19.8	19.3	19.7	20.2	20.9	20.2	20.6	21.2	21.9												
Start Kit	NAMA001SC	Temp Rise		35 - 65			HI PR	167	179	190	198	190	204	216	225	216	233	246	256	243	262	276	288	269	289	305	318												
Cond & Evap	Cond	Evap	Ignition Type		HSP		LO PR	67	71	78	83	70	74	81	86	73	78	85	91	77	82	89	95	79	85	92	98												
Type	Fan	Blower	Fan On/Off		TIME		80	MBh	39.9	40.8	43.6	46.6	39.0	39.8	42.5	45.5	38.0	38.8	41.5	44.4	36.1	36.9	39.4	42.1	33.5	34.2	36.5	39.0											
Size	22	DD10-9	Limit Set Max		140			S/T	0.95	0.89	0.73	0.54	0.98	0.92	0.75	0.56	1.00	0.95	0.77	0.58	1.00	0.98	0.80	0.60	1.00	0.99	0.81	0.60											
Motor-HP	1/2	1/2	Heat Antic		0.58		80	AMPS	16.3	16.6	17.1	17.6	17.4	17.8	18.3	18.9	18.4	18.8	19.3	19.9	19.4	19.8	20.4	21.0	20.4	20.8	21.4	22.1											
Type	PSC	PSC	HI PR		168			181	191	200	192	206	218	227	218	235	248	259	246	264	279	291	271	292	308	322													
FLA	1.8	4.4	LO PR		68		72	79	84	70	75	82	87	74	79	86	92	78	83	90	96	80	85	93	99														
LRA	6	8.6	85		85	MBh	40.6	41.4	43.4	46.3	39.6	40.4	42.3	45.2	38.7	39.4	41.3	44.1	36.7	37.5	39.2	41.9	34.0	34.7	36.3	38.8													
RPM	1145	1125	S/T			1.00		0.96	0.87	0.71	1.00	0.99	0.89	0.72	1.00	1.00	0.92	0.75	1.00	1.00	0.96	0.78	1.00	1.00	0.96	0.78													
Cap MFD/V	7.5/440	15/370	AMPS		16.4		16.7	17.2	17.7	17.6	17.9	18.4	19.0	18.6	19.0	19.5	20.1	19.6	20.0	20.5	21.2	20.5	21.0	21.6	22.3														
PTCR			HI PR		170		183	193	202	194	208	220	229	220	237	250	261	248	267	282	294	274	295	311	325														
Hi Press			LO PR		69		73	80	85	71	76	83	88	75	80	87	93	78	83	91	97	81	86	94	100														
Low Press			Air Delivery in CFM - Dry Coil - No Filter (Add .05 static for Wet Coil)																																				
Operating Chg (No Lines)*	(R-22 Oz)	180	230 Volt		External Static Press (Inch Water Column)							208 Volt		External Static Press (Inch Water Column)																									
			Speed Tap	0.1	0.2	0.3	0.4	0.5	0.6	0.7	Speed Tap	0.1	0.2	0.3	0.4	0.5	0.6	0.7																					
Service Driers	16 Cu In / 11 oz	Suction	HI		1925	1860	1795	1725	1650	1570	1485	HI		1805	1755	1700	1640	1575	1500	1415																			
			MD HI	1785	1735	1680	1620	1560	1485	1405	MD HI	1610	1580	1540</																									

Technical Service Data Sheets 1067963 & 1067964

Style No: PGAD47D1K			Outdoor Ambient Temperature - Degrees F. Dry Bulb																			
			75				85				95				105				115			
			Entering Indoor Temperature - Degrees F. Wet Bulb																			
			59				63				67				71				75			
Voltage	208 / 230		Gas Type	NAT			IDB			70			75			80			85			
Phase	1		Std Input	90			MBh			S/T			AMPS			HI PR			LO PR			
Ampacity	35.8		Low Fire Input	75			44.6 46.2 50.7 -			43.5 45.1 49.4 -			42.5 44.0 48.2 -			40.4 41.8 45.8 -			37.4 38.7 42.5 -			
Wire Ga/Ft	8 / 61		Std Output	71			0.77 0.65 0.45 -			0.79 0.66 0.46 -			0.82 0.68 0.47 -			0.85 0.71 0.49 -			0.86 0.72 0.50 -			
Delay Fuse	45		Low Fire Output	60			17.9 18.3 18.8 -			19.2 19.6 20.1 -			20.3 20.7 21.3 -			21.4 21.8 22.5 -			22.5 22.9 23.6 -			
Max. Fuse	50		Gas Valve (HSP)	HW			178 192 203 -			203 218 231 -			231 249 263 -			260 280 295 -			287 309 326 -			
Compressor	COPELAND		Regulation	SNAP			65 69 75 -			67 72 78 -			71 75 82 -			74 79 86 -			77 82 89 -			
RLA	23.7		Manifold Press	3.5			45.4 46.7 50.6 54.3			44.3 45.6 49.3 53.0			43.2 44.5 48.1 51.7			41.0 42.3 45.7 49.1			38.0 39.1 42.4 45.5			
LRA	129		Std orifice	43			0.88 0.79 0.60 0.38			0.90 0.81 0.61 0.39			0.93 0.83 0.63 0.41			0.97 0.86 0.65 0.42			0.98 0.87 0.66 0.42			
Cap MFD/V	60 / 440		Low Fire Orifice	46			18.1 18.4 18.9 19.5			19.3 19.7 20.3 20.9			20.5 20.9 21.5 22.1			21.6 22.0 22.6 23.4			22.6 23.1 23.8 24.6			
CC Heater			Pilot Orifice	0.018			180 194 205 214			205 221 233 243			233 251 265 277			263 283 298 311			290 312 330 344			
Start Kit	NAMA001SC		Temp Rise	30 - 60			66 70 76 81			68 73 79 84			72 76 83 89			75 80 87 93			78 83 90 96			
Cond & Evap	Cond	Evap	Ignition Type	HSP			46.2 47.2 50.4 53.9			45.1 46.1 49.2 52.6			44.0 44.9 48.0 51.3			41.8 42.7 45.6 48.7			38.7 39.5 42.2 45.2			
Type	Fan	Blower	Fan On/Off	TIME			0.97 0.91 0.74 0.55			0.99 0.93 0.76 0.56			1.00 0.96 0.78 0.58			1.00 0.99 0.81 0.61			1.00 1.00 0.82 0.61			
Size	22	DD10-9	Limit Set Max	135			18.2 18.6 19.1 19.7			19.5 19.9 20.4 21.1			20.6 21.0 21.6 22.3			21.7 22.2 22.8 23.6			22.8 23.3 24.0 24.8			
Motor-HP	1/2	1/2	Heat Antic	0.58			182 196 207 216			207 223 235 245			236 254 268 280			265 286 302 314			293 315 333 347			
Type	PSC	PSC					66 70 77 82			69 73 80 85			72 77 84 89			76 81 88 94			78 83 91 97			
FLA	1.8	4.4					47.0 47.9 50.1 53.5			45.9 46.7 49.0 52.2			44.7 45.6 47.8 51.0			42.5 43.3 45.4 48.4			39.4 40.1 42.0 44.8			
LRA	6	8.6					1.00 0.98 0.88 0.72			1.00 1.00 0.90 0.73			1.00 1.00 0.93 0.76			1.00 1.00 0.97 0.79			1.00 1.00 0.98 0.79			
RPM	1145	1125					18.3 18.7 19.2 19.8			19.6 20.0 20.6 21.3			20.8 21.2 21.8 22.5			21.9 22.4 23.0 23.8			23.0 23.5 24.2 25.0			
Cap MFD/V	7.5/440	15/370					184 198 209 218			209 225 238 248			238 256 271 282			268 288 305 318			296 319 336 351			
PTCR							67 71 78 83			70 74 81 86			73 78 85 90			77 81 89 95			79 84 92 98			
Hi Press							Air Delivery in CFM - Dry Coil - No Filter (Add .05 static for Wet Coil)															
Low Press							230 Volt				208 Volt											
Operating Chg (No Lines)*	(R-22 Oz) 215						External Static Press (Inch Water Column)				External Static Press (Inch Water Column)											
Service Driers							Speed Tap				Speed Tap											
Liquid/Chg	30 Cu In / 17 oz						0.1 0.2 0.3 0.4 0.5 0.6 0.7				0.1 0.2 0.3 0.4 0.5 0.6 0.7											
Suction	30 Sq In						HI				HI											
Unit Weight	600						1925 1860 1795 1725 1650 1570 1485				1805 1755 1700 1640 1575 1500 1415											
							MD HI				MD HI											
							1785 1735 1680 1620 1560 1485 1405				1610 1580 1540 1495 1440 1375 1300											
							MD LO				MD LO											
							1570 1540 1505 1465 1415 1380 1280				1385 1355 1330 1300 1265 1215 1155											
							LO				LO											
							1485 1460 1430 1395 1345 1290 1225				1270 1265 1250 1225 1190 1140 1085				1067963							

Style No: PGAD47F1K			Outdoor Ambient Temperature - Degrees F. Dry Bulb																			
			75				85				95				105				115			
			Entering Indoor Temperature - Degrees F. Wet Bulb																			
			59				63				67				71				75			
Voltage	208 / 230		Gas Type	NAT			IDB			70			75			80			85			
Phase	1		Std Input	135 / 110			MBh			S/T			AMPS			HI PR			LO PR			
Ampacity	36		Low Fire Input	110			44.6 46.2 50.7 -			43.5 45.1 49.4 -			42.5 44.0 48.2 -			40.4 41.8 45.8 -			37.4 38.7 42.5 -			
Wire Ga/Ft	8 / 61		Std Output	106			0.77 0.65 0.45 -			0.79 0.66 0.46 -			0.82 0.68 0.47 -			0.85 0.71 0.49 -			0.86 0.72 0.50 -			
Delay Fuse	45		Low Fire Output	87			17.9 18.3 18.8 -			19.2 19.6 20.1 -			20.3 20.7 21.3 -			21.4 21.8 22.5 -			22.5 22.9 23.6 -			
Max. Fuse	50		Gas Valve (HSP)	HW			178 192 203 -			203 218 231 -			231 249 263 -			260 280 295 -			287 309 326 -			
Compressor	COPELAND		Regulation	SNAP			65 69 75 -			67 72 78 -			71 75 82 -			74 79 86 -			77 82 89 -			
RLA	23.7		Manifold Press	3.5			45.4 46.7 50.6 54.3			44.3 45.6 49.3 53.0			43.2 44.5 48.1 51.7			41.0 42.3 45.7 49.1			38.0 39.1 42.4 45.5			
LRA	129		Std orifice	43			0.88 0.79 0.60 0.38			0.90 0.81 0.61 0.39			0.93 0.83 0.63 0.41			0.97 0.86 0.65 0.42			0.98 0.87 0.66 0.42			
Cap MFD/V	60 / 440		Low Fire Orifice	46			18.1 18.4 18.9 19.5			19.3 19.7 20.3 20.9			20.5 20.9 21.5 22.1			21.6 22.0 22.6 23.4			22.6 23.1 23.8 24.6			
CC Heater			Pilot Orifice	0.018			180 194 205 214			205 221 233 243			233 251 265 277			263 283 298 311			290 312 330 344			
Start Kit	NAMA001SC		Temp Rise	35 - 65			66 70 76 81			68 73 79 84			72 76 83 89			75 80 87 93			78 83 90 96			
Cond & Evap	Cond	Evap	Ignition Type	HSP			46.2 47.2 50.4 53.9			45.1 46.1 49.2 52.6			44.0 44.9 48.0 51.3			41.8 42.7 45.6 48.7			38.7 39.5 42.2 45.2			
Type	Fan	Blower	Fan On/Off	TIME			0.97 0.91 0.74 0.55			0.99 0.93 0.76 0.56			1.00 0.96 0.78 0.58			1.00 0.99 0.81 0.61			1.00 1.00 0.82 0.61			
Size	22	DD11-11	Limit Set Max	135			18.2 18.6 19.1 19.7			19.5 19.9 20.4 21.1			20.6 21.0 21.6 22.3			21.7 22.2 22.8 23.6			22.8 23.3 24.0 24.8			
Motor-HP	1/2	1	Heat Antic	0.58			182 196 207 216			207 223 235 245			236 254 268 280			265 286 302 314			293 315 333 347			
Type	PSC	PSC					66 70 77 82			69 73 80 85			72 77 84 89			76 81 88 94			78 83 91 97			
FLA	1.8	4.6					47.0 47.9 50.1 53.5			45.9 46.7 49.0 52.2			44.7 45.6 47.8 51.0			42.5 43.3 45.4 48.4			39.4 40.1 42.0 44.8			
LRA	6	7.9					1.00 0.98 0.88 0.72			1.00 1.00 0.90 0.73			1.00 1.00 0.93 0.76			1.00 1.00 0.97 0.79			1.00 1.00 0.98 0.79			
RPM	1145	1125					18.3 18.7 19.2 19.8			19.6 20.0 20.6 21.3			20.8 21.2 21.8 22.5			21.9 22.4 23.0 23.8			23.0 23.5 24.2 25.0			
Cap MFD/V	7.5/440	15/370					184 198 209 218			209 225 238 248			238 256 271 282			268 288 305 318			296 319 336 351			
PTCR							67 71 78 83			70 74 81 86			73 78 85 90			77 81 89 95			79 84 92 98			
Hi Press							Air Delivery in CFM - Dry Coil - No Filter (Add .05 static for Wet Coil)															
Low Press							230 Volt				208 Volt											
Operating Chg (No Lines)*	(R-22 Oz) 215						External Static Press (Inch Water Column)				External Static Press (Inch Water Column)											
Service Driers							Speed Tap				Speed Tap											
Liquid/Chg	30 Cu In / 17 oz						0.1 0.2 0.3 0.4 0.5 0.6 0.7				0.1 0.2 0.3 0.4 0.5 0.6 0.7											
Suction	30 Sq In						HI				HI											
Unit Weight	610						2260 2185 2125 2065 2010 1950 1875				2025 1995 1960 1915 1870 1810 1745											
							MD HI				MD HI											
							1830 1805 1775 1735 1690 1635 1580				1560 1545 1530 1505 1475 1435 1390											
							MD LO				MD LO											
							- - - - -				- - - - -											
							LO				LO											
							1700 1685 1660 1625 1585 1540 1485				1445 1430 1415 1390 1355 1320 1275				1067964							

Technical Service Data Sheets 1067965 & 1067966

Style No: PGAD60E1K			Outdoor Ambient Temperature - Degrees F. Dry Bulb																									
			75				85				95				105				115									
			Entering Indoor Temperature - Degrees F. Wet Bulb																									
			59 63 67 71				59 63 67 71				59 63 67 71				59 63 67 71				59 63 67 71									
Voltage	208 / 230		Gas Type	NAT	IDB																							
Phase	1		Std Input	115																								
Ampacity	42.9		Low Fire Input	95																								
Wire Ga/Ft	6 / 76		Std Output	91																								
Delay Fuse	60		Low Fire Output	75	70	MBh	54.4	56.3	61.7	-	53.1	55.0	60.3	-	51.8	53.7	58.8	-	49.2	51.0	55.9	-	45.6	47.2	51.7	-		
Max. Fuse	70		Gas Valve (HSP)	HW		S/T	0.72	0.61	0.42	-	0.74	0.62	0.43	-	0.77	0.64	0.44	-	0.80	0.66	0.46	-	0.80	0.67	0.46	-		
Compressor	COPELAND		Regulation	SNAP		AMPS	22.5	22.9	23.6	-	24.1	24.6	25.3	-	25.5	26.1	26.8	-	26.9	27.5	28.3	-	28.3	29.0	29.8	-		
RLA	28.8		Manifold Press	3.5		HI PR	186	201	212	-	212	228	241	-	241	260	274	-	272	292	309	-	300	323	341	-		
LRA	169		Pilot Orifice	0.018	75	LO PR	65	69	75	-	67	71	78	-	70	75	82	-	74	79	86	-	76	81	89	-		
Cap MFD/V	80 / 440		Temp Rise	30 - 60		MBh	55.3	56.9	61.6	66.1	54.0	55.6	60.1	64.5	52.7	54.2	58.7	63.0	50.0	51.5	55.7	59.8	46.3	47.7	51.6	55.4		
CC Heater	NAMA001SC		Ignition Type	HSP		S/T	0.82	0.74	0.56	0.36	0.84	0.76	0.57	0.37	0.87	0.78	0.59	0.38	0.90	0.81	0.61	0.39	0.91	0.82	0.62	0.40		
Start Kit	Cond	Evap	Fan On/Off	TIME		AMPS	22.6	23.1	23.7	24.5	24.3	24.8	25.5	26.3	25.7	26.3	27.0	27.9	27.2	27.8	28.6	29.5	28.6	29.2	30.1	31.1		
Cond & Evap	Fan	Blower	Limit Set Max	135	80	HI PR	188	203	214	223	214	230	243	254	244	263	277	289	274	295	312	325	303	326	345	359		
Type	PSC	PSC	Heat Antic	0.58		LO PR	65	69	76	81	68	72	79	84	71	76	83	88	75	79	87	92	77	82	90	95		
Size	22	DD11-11				MBh	56.3	57.5	61.4	65.7	54.9	56.1	60.0	64.1	53.6	54.8	58.5	62.5	50.9	52.0	55.6	59.4	47.2	48.2	51.5	55.0		
Motor-HP	1/2	1				S/T	0.90	0.85	0.69	0.52	0.93	0.87	0.71	0.53	0.96	0.90	0.73	0.55	0.99	0.93	0.76	0.57	1.00	0.94	0.76	0.57		
Type	6	8.6			85	AMPS	22.8	23.3	23.9	24.7	24.5	25.0	25.7	26.6	25.9	26.5	27.3	28.2	27.4	28.0	28.8	29.8	28.8	29.4	30.3	31.4		
FLA	1.8	5				HI PR	190	205	216	225	216	233	246	256	246	265	280	292	277	298	315	329	306	330	348	363		
LRA	6	1140				LO PR	66	70	76	81	68	73	79	85	72	76	84	89	75	80	88	93	78	83	91	96		
RPM	1145	1140				MBh	57.2	58.4	61.1	65.2	55.9	57.0	59.7	63.7	54.5	55.6	58.2	62.1	51.8	52.8	55.3	59.0	48.0	48.9	51.2	54.6		
Cap MFD/V	7.5/440	20/370			S/T	0.95	0.91	0.82	0.67	0.97	0.94	0.85	0.69	1.00	0.97	0.87	0.71	1.00	1.00	0.91	0.74	1.00	1.00	0.91	0.74			
PTCR					Air Delivery in CFM - Dry Coil - No Filter (Add .05 static for Wet Coil)	AMPS	23.0	23.5	24.1	24.9	24.7	25.2	25.9	26.8	26.1	26.7	27.5	28.4	27.6	28.2	29.0	30.0	29.1	29.7	30.6	31.6		
Hi Press						HI PR	192	207	218	228	219	235	248	259	249	268	283	295	280	301	318	332	309	333	352	367		
Low Press						LO PR	67	71	77	82	69	74	80	86	73	77	84	90	76	81	88	94	79	84	91	97		
Operating Chg (No Lines)*	(R-22 Oz) 215					230 Volt External Static Press (Inch Water Column)												208 Volt External Static Press (Inch Water Column)										
Service Driers					Speed Tap				0.1 0.2 0.3 0.4 0.5 0.6 0.7				Speed Tap				0.1 0.2 0.3 0.4 0.5 0.6 0.7											
Liquid/Chg	30 Cu In / 17 oz				HI	2300	2250	2190	2125	2060	1990	1915	HI	2110	2065	2020	1975	1925	1860	1790								
Suction	30 Sq In				MD HI	2130	2090	2045	1995	1875	1805	1580	MD HI	1880	1855	1825	1790	1750	1695	1635								
Unit Weight	625				MD LO	1670	1650	1630	1600	1565	1525	1475	MD LO	1405	1390	1375	1355	1330	1295	1250								
					LO	1330	1315	1300	1280	1255	1225	1185	LO	1110	1100	1080	1060	1035	1000	950								

Style No: PGAD60G1K			Outdoor Ambient Temperature - Degrees F. Dry Bulb																								
			75				85				95				105				115								
			Entering Indoor Temperature - Degrees F. Wet Bulb																								
			59 63 67 71				59 63 67 71				59 63 67 71				59 63 67 71				59 63 67 71								
Voltage	208 / 230		Gas Type	NAT	IDB																						
Phase	1		Std Input	150																							
Ampacity	43.9		Low Fire Input	130																							
Wire Ga/Ft	6 / 76		Std Output	119																							
Delay Fuse	60		Low Fire Output	102	70	MBh	54.4	56.3	61.7	-	53.1	55.0	60.3	-	51.8	53.7	58.8	-	49.2	51.0	55.9	-	45.6	47.2	51.7	-	
Max. Fuse	70		Gas Valve (HSP)	HW		S/T	0.72	0.61	0.42	-	0.74	0.62	0.43	-	0.77	0.64	0.44	-	0.80	0.66	0.46	-	0.80	0.67	0.46	-	
Compressor	COPELAND		Regulation	SNAP		AMPS	22.5	22.9	23.6	-	24.1	24.6	25.3	-	25.5	26.1	26.8	-	26.9	27.5	28.3	-	28.3	29.0	29.8	-	
RLA	28.8		Manifold Press	3.5		HI PR	186	201	212	-	212	228	241	-	241	260	274	-	272	292	309	-	300	323	341	-	
LRA	169		Pilot Orifice	0.018	75	LO PR	65	69	75	-	67	71	78	-	70	75	82	-	74	79	86	-	76	81	89	-	
Cap MFD/V	80 / 440		Temp Rise	35 - 65		MBh	55.3	56.9	61.6	66.1	54.0	55.6	60.1	64.5	52.7	54.2	58.7	63.0	50.0	51.5	55.7	59.8	46.3	47.7	51.6	55.4	
CC Heater	NAMA001SC		Ignition Type	HSP		S/T	0.82	0.74	0.56	0.36	0.84	0.76	0.57	0.37	0.87	0.78	0.59	0.38	0.90	0.81	0.61	0.39	0.91	0.82	0.62	0.40	
Start Kit	Cond	Evap	Fan On/Off	TIME		AMPS	22.6	23.1	23.7	24.5	24.3	24.8	25.5	26.3	25.7	26.3	27.0	27.9	27.2	27.8	28.6	29.5	28.6	29.2	30.1	31.1	
Cond & Evap	Fan	Blower	Limit Set Max	130	80	HI PR	188	203	214	223	214	230	243	254	244	263	277	289	274	295	312	325	303	326	345	359	
Type	PSC	PSC	Heat Antic	0.58		LO PR	65	69	76	81	68	72	79	84	71	76	83	88	75	79	87	92	77	82	90	95	
Size	22	DD11-11				MBh	56.3	57.5	61.4	65.7	54.9	56.1	60.0	64.1	53.6	54.8	58.5	62.5	50.9	52.0	55.6	59.4	47.2	48.2	51.5	55.0	
Motor-HP	1/2	1				S/T	0.90	0.85	0.69	0.52	0.93	0.87	0.71	0.53	0.96	0.90	0.73	0.55	0.99	0.93	0.76	0.57	1.00	0.94	0.76	0.57	
Type	6	15.1			85	AMPS	22.8	23.3	23.9	24.7	24.5	25.0	25.7	26.6	25.9	26.5	27.3	28.2	27.4	28.0	28.8	29.8	28.8	29.4	30.3	31.4	
FLA	1.8	6				HI PR	190	205	216	225	216	233	246	256	246	265	280	292	277	298	315	329	306	330	348	363	
LRA	6	1140				LO PR	66	70	76	81	68	73	79	85	72	76	84	89	75	80	88	93	78	83	91	96	
RPM	1145	1140				MBh	57.2	58.4	61.1	65.2	55.9	57.0	59.7	63.7	54.5	55.6	58.2	62.1	51.8	52.8	55.3	59.0	48.0	48.9	51.2	54.6	
Cap MFD/V	7.5/440	20/370			S/T	0.95	0.91	0.82	0.67	0.97	0.94	0.85	0.69	1.00	0.97	0.87	0.71	1.00	1.00	0.91	0.74	1.00	1.00	0.91	0.74		
PTCR					Air Delivery in CFM - Dry Coil - No Filter (Add .05 static for Wet Coil)	AMPS	23.0	23.5	24.1	24.9	24.7	25.2	25.9	26.8	26.1	26.7	27.5	28.4	27.6	28.2	29.0	30.0	29.1	29.7	30.6	31.6	
Hi Press						HI PR	192	207	218	228	219	235	248	259	249	268	283	295	280	301	318	332	309	333	352	367	
Low Press						LO PR	67	71	77	82	69	74	80	86	73	77	84	90	76	81	88	94	79	84	91	97	
Operating Chg (No Lines)*	(R-22 Oz) 215					230 Volt External Static Press (Inch Water Column)				208 Volt External Static Press (Inch Water Column)																	
Service Driers					Speed Tap				Speed Tap																		
Liquid/Chg	30 Cu In / 17 oz				HI	2470	2400	2325	2250	2170	2085	2000	HI	2380	2315	2250	2185	2105	2020	1940							
Suction	30 Sq In				MD HI	2395	2335	2270	2200	2125	2050	1965	MD HI	2310	2250	2185	2125	2060	1980	1905							
Unit Weight	630				MD LO	2260	2205	2145	2080	2015	1940	1865	MD LO	2090	2045	1995	1945	1890	1820	1750							
					LO	2140	2095	2040	1985	1920	1855	1780	LO	1915	1885	1845	1805	1755	1700	1640							

Technical Service Data Sheets 1067984 & 1067985

Model or Style No. PGAA47D1K		Performance Data: 80°F Dry Bulb Indoor											
Specifications		Coil - Internal					Rated 1600 CFM .20 ESP Wet.						
		Low Wet Bulb (63°F)					High Wet Bulb (69°F)						
		Ambient Outdoor °F	Approx. MBTUH	Sens. Total Ratio	PSIG. Liquid (Head)	PSIG. Suct.	Unit Amps	Ambient Outdoor °F	Approx. MBTUH	Sens. Total Ratio	PSIG. Liquid (Head)	PSIG. Suct.	Unit Amps
Electrical: Voltage-Phase-Hz Branch Circuit Ampacity Wire Size/Max. Ft. Time Delay/HACR Brkr. Max. Fuse Boost Transformer	208/230-1-60 35.8 No. 6 / 97'	65	48.3	0.86	183	61	20.2	65	52.9	0.60	198	70	21.3
	45	75	47.3	0.88	205	64	21.6	75	51.7	0.62	221	74	22.8
	50	85	46.5	0.90	233	68	23.0	85	50.8	0.64	251	77	24.3
	---	95	45.3	0.92	265	71	24.4	95	49.5	0.65	286	81	25.8
	---	105	43.1	0.93	297	74	25.8	105	47.2	0.66	321	84	27.2
Fan Motor: H.P./Type FLA/LRA Speeds/CFM Cap. MFD/Volts	COND. 1/2 PSC EVAP. 1/2 PSC	115	39.4	0.93	328	77	27.2	115	43.2	0.66	354	87	28.7
	1.8 / 6.42 1 / 4500 7.5 / 440	Blower Performance Data (Add 0.05 In. W.C. for wet coil)											
	Heating Data												
	Compressor: FLA/LRA Run Cap. MFD./Volts Acc. Start Kit												
	Service Driers: Liquid/Charge Suction												
Ref. Charge (R-22 Oz.) 124		Gas Type Nat					External Static Pressure						
Clearances See Installation Instructions		Input (MBTUH) 90 / 75					Inches of W. C.						
		Output (MBTUH) 71 / 60											
		Gas Valve (HSP) HW											
		Regulation Type Snap											
		Manifold Pressure 3.5											
		Orifices 43/46											
		Pilot Orifice Size .018											
		Temp. Rise 0F 30-60											
		Ignition Type HSP											
		Fan Control (ON/OFF) TIME											
Clearances See Installation Instructions		Limit Control (MAX) 135					CFM @ 230V - Dry Coil (no filter)						
		Heat Anticipator .58											
		CFM @ 208V - Dry Coil (no filter)											
		TAP											
		LOW											
		MED L											
		MED H											
		HIGH											
		.10											
		.20											
.30													
.40													
.50													
.60													
.70													

Note: Optimum operating charge will produce 15° - 25° F suction line superheat at compressor with 82° F outdoor ambient and 80° F dry bulb (67° F wet bulb) indoor temperature at rated airflow.

1067984
9-22-94
AH-1

Model or Style No. PGAA47F1K		Performance Data: 80°F Dry Bulb Indoor											
Specifications		Coil - Internal					Rated 1600 CFM .30 ESP Wet.						
		Low Wet Bulb (63°F)					High Wet Bulb (69°F)						
		Ambient Outdoor °F	Approx. MBTUH	Sens. Total Ratio	PSIG. Liquid (Head)	PSIG. Suct.	Unit Amps	Ambient Outdoor °F	Approx. MBTUH	Sens. Total Ratio	PSIG. Liquid (Head)	PSIG. Suct.	Unit Amps
Electrical: Voltage-Phase-Hz Branch Circuit Ampacity Wire Size/Max. Ft. Time Delay/HACR Brkr. Max. Fuse Size Boost Transformer	208/230-1-60 36.0 No. 6 / 97'	65	48.3	0.86	183	61	20.2	65	52.9	0.60	198	70	21.3
	45	75	47.3	0.88	205	64	21.6	75	51.7	0.62	221	74	22.8
	50	85	45.6	0.90	233	68	23.0	85	50.8	0.64	251	77	24.3
	---	95	45.3	0.92	265	71	24.4	95	49.5	0.65	286	81	25.8
	---	105	43.1	0.93	297	74	25.8	105	47.2	0.66	321	84	27.2
Fan Motor: H.P./Type FLA/LRA Speeds/CFM Cap. MFD/Volts	COND. 1/2 PSC EVAP. 1 PSC	115	39.4	0.93	328	77	27.2	115	43.2	0.66	354	87	28.7
	1.8 / 6.42 1 / 4500 7.5 / 440	Blower Performance Data (add 0.05 In. W.C. for wet coil)											
	Heating Data												
	Compressor: FLA/LRA Run Cap. MFD./Volts Acc. Start Kit												
	Service Driers: Liquid/Charge Suction												
Ref. Charge (R-22 Oz.) 124		Gas Type Nat					External Static Pressure						
Clearances See Installation Instructions		Input (MBTUH) 135 / 110					Inches of W. C.						
		Output (MBTUH) 106 / 87											
		Gas Valve (HSP) HW											
		Regulation Type Snap											
		Manifold Pressure 3.5											
		Orifices 43/46											
		Pilot Orifice Size .018											
		Temp. Rise 0F 35-65											
		Ignition Type HSP											
		Fan Control (ON/OFF) TIME											
Clearances See Installation Instructions		Limit Control (MAX) 135					CFM @ 230V - Dry Coil (no filter)						
		Heat Anticipator .58											
		CFM @ 208V - Dry Coil (no filter)											
		TAP											
		LOW											
		MED L											
		MED H											
		HIGH											
		.10											
		.20											
.30													
.40													
.50													
.60													
.70													

Note: Optimum operating charge will produce 15° - 25° F suction line superheat at compressor with 82° F outdoor ambient and 80° F dry bulb (67° F wet bulb) indoor temperature at rated airflow.

1067985
9-22-94
AH-1

Technical Service Data Sheets 1067986 & 1067989

Model or Style No. PGAA60D1K		Performance Data: 80°F Dry Bulb Indoor											
Specifications		Coil – Internal					Rated 2000 CFM .30 ESP Wet.						
		Low Wet Bulb (63°F)					High Wet Bulb (69°F)						
		Ambient Outdoor °F	Approx. MBTUH	Sens. Total Ratio	PSIG. Liquid (Head)	PSIG. Suct.	Unit Amps	Ambient Outdoor °F	Approx. MBTUH	Sens. Total Ratio	PSIG. Liquid (Head)	PSIG. Suct.	Unit Amps
Electrical: Voltage–Phase–Hz Branch Circuit Ampacity Wire Size/Max. Ft. Time Delay/HACR Brk. Max. Fuse Boost Transformer	208/230–1–60 43.7 No. 6 / 70' 60 60 – – – –	65	59.9	0.86	197	63	25.2	65	65.5	0.60	213	72	26.5
		75	58.6	0.88	221	67	27.0	75	64.1	0.62	238	76	28.4
		85	57.6	0.90	251	70	28.7	85	63.0	0.64	271	80	30.3
		95	56.1	0.92	285	73	30.5	95	61.4	0.65	308	84	32.1
		105	53.5	0.93	321	76	32.2	105	58.5	0.66	346	87	33.9
		115	48.9	0.93	354	79	33.9	115	53.5	0.66	382	90	35.7
Fan Motor: H.P./Type FLA/LRA Speeds/CFM Cap. MFD/Volts	COND. 3 / 4 PSC 2.6 / 9.52 1 / 4500 10 / 440	EVAP. 1 PSC 5.0 / 8.75 4 / 2250 20 / 370	Heating Data					Blower Performance Data (add 0.05 In. W.C. for wet coil)					
Compressor: FLA/LRA Run Cap. MFD./Volts Acc. Start Kit	Copeland (Scroll) 28.8 / 169 55/440 NAMA001SC		Gas Type	Nat			External Static Pressure Inches of W. C.	CFM @ 230V – Dry Coil (no filter)					
Service Driers: Liquid/Charge Suction	30 cu in / 17oz 30 sq in		Input (MBTUH)	90 / 75				TAP	LOW	MED L	MED H	HIGH	
Ref. Charge (R-22 Oz.)	122		Output (MBTUH)	71 / 59				.10	1330	1670	2130	2300	
Clearances See Installation Instructions			Gas Valve (HSP)	HW				.20	1315	1650	2090	2250	
			Regulation Type	Snap				.30	1300	1630	2045	2190	
			Manifold Pressure	3.5				.40	1280	1600	1995	2125	
			Orifices	43/46				.50	1255	1565	1935	2060	
			Pilot Orifice Size	.018				.60	1225	1525	1875	1990	
			Temp. Rise 0F	33 / 60				.70	1185	1475	1805	1915	
			Ignition Type	HSP				CFM @ 208V – Dry Coil (no filter)					
			Fan Control (ON/OFF)	TIME				TAP	LOW	MED L	MED H	HIGH	
			Limit Control (MAX)	135				.10	1110	1405	1880	2110	
			Heat Anticipator	.58				.20	1100	1390	1855	2065	
								.30	1080	1375	1825	2020	
							.40	1060	1355	1790	1975		
							.50	1035	1330	1750	1925		
							.60	1000	1295	1695	1860		
							.70	950	1250	1635	1790		

Note: Optimum operating charge will produce 15° – 25° F suction line superheat at compressor with 82° F outdoor ambient and 80° F dry bulb (67° F wet bulb) indoor temperature at rated airflow.

1067986
9–22–94
AH–1

Model or Style No. PGAA60G1K		Performance Data: 80°F Dry Bulb Indoor											
Specifications		Coil – Internal					Rated 2000 CFM .30 ESP Wet.						
		Low Wet Bulb (63°F)					High Wet Bulb (69°F)						
		Ambient Outdoor °F	Approx. MBTUH	Sens. Total Ratio	PSIG. Liquid (Head)	PSIG. Suct.	Unit Amps	Ambient Outdoor °F	Approx. MBTUH	Sens. Total Ratio	PSIG. Liquid (Head)	PSIG. Suct.	Unit Amps
Electrical: Voltage–Phase–Hz Branch Circuit Ampacity Wire Size/Max. Ft. Time Delay Fuse Size Max. Fuse/HACR Brk. Boost Transformer	208/230–1–60 44.7 No. 6 / 70' 60 60 – – – –	65	59.9	0.86	197	63	25.2	65	65.5	0.60	213	72	26.5
		75	58.6	0.88	221	67	27.0	75	64.1	0.62	238	76	28.4
		85	57.6	0.90	251	70	28.7	85	63.0	0.64	271	80	30.3
		95	56.1	0.92	285	73	30.5	95	61.4	0.65	308	84	32.1
		105	53.5	0.93	321	76	32.2	105	58.5	0.66	346	87	33.9
		115	48.9	0.93	354	79	33.9	115	53.5	0.66	382	90	35.7
Fan Motor: H.P./Type FLA/LRA Speeds/CFM Cap. MFD/Volts	COND. 3 / 4 PSC 2.6 / 9.52 1 / 4500 10 / 440	EVAP. 1 PSC 6.0 / 15.14 4 / 2400 20 / 440	Heating Data					Blower Performance Data (Add 0.05 In. W.C. for wet coil)					
Compressor: FLA/LRA Run Cap. MFD./Volts Acc. Start Kit	Copeland (Scroll) 28.8 / 169 55 / 440 NAMA001SC		Gas Type	Nat			External Static Pressure Inches of W. C.	CFM @ 230V – Dry Coil (no filter)					
Service Driers: Liquid/Charge Suction	30 cu in / 17oz 30 sq in		Input (MBTUH)	150/130				TAP	LOW	MED L	MED H	HIGH	
Ref. Charge (R-22 Oz.)	122		Output (MBTUH)	119 / 102				.10	2140	2260	2395	2470	
Clearances See Installation Instructions			Gas Valve (HSP)	HW				.20	2095	2205	2335	2400	
			Regulation Type	Snap				.30	2040	2145	2270	2325	
			Manifold Pressure	3.5				.40	1985	2080	2200	2250	
			Orifices	43/46				.50	1920	2015	2125	2170	
			Pilot Orifice Size	.018				.60	1855	1940	2050	2085	
			Temp. Rise 0F	35–65				.70	1780	1865	1965	2000	
			Ignition Type	HSP				CFM @ 208V – Dry Coil (no filter)					
			Fan Control (ON/OFF)	TIME				TAP	LOW	MED L	MED H	HIGH	
			Limit Control (MAX)	130				.10	1915	2090	2310	2380	
			Heat Anticipator	.58				.20	1885	2045	2250	2315	
								.30	1845	1995	2185	2250	
							.40	1805	1945	2125	2185		
							.50	1755	1890	2060	2105		
							.60	1700	1820	1980	2020		
							.70	1640	1750	1905	1940		

Note: Optimum operating charge will produce 15° – 25° F suction line superheat at compressor with 82° F outdoor ambient and 80° F dry bulb (67° F wet bulb) indoor temperature at rated airflow.

1067989
9–22–94
AH–1

Technical Service Data Sheet 1068368

Model or Style No. PGAA60G1K																	
Specifications			Performance Data: 80°F Dry Bulb Indoor														
			Coil – Internal			Rated 2000 CFM			.30 ESP Wet.								
			Low Wet Bulb (63°F)						High Wet Bulb (69°F)								
Electrical: Voltage–Phase–Hz Branch Circuit Ampacity Wire Size/Max. Ft. Time Delay Fuse Size Max. Fuse/HACR Brk. Boost Transformer			208/230–1–60 44.7 No. 6 / 70' 60 60 – – – –														
Fan Motor: H.P./Type FLA/LRA Speeds/CFM Cap. MFD/Volts			COND. 3 / 4 PSC 2.6 / 9.52 1 / 4500 10 / 440			EVAP. 1 PSC 6.0 / 15.14 4 / 2400 20 / 440											
Compressor: FLA/LRA Run Cap. MFD./Volts Acc. Start Kit			Copeland (Scroll) 28.8 / 169 55 / 440 NAMA001SC														
Service Driers: Liquid/Charge Suction			30 cu in / 17oz 30 sq in														
Ref. Charge (R-22 Oz.)			122														
Clearances See Installation Instructions																	
			Heating Data									Blower Performance Data (Add 0.05 In. W.C. for wet coil)					
			Gas Type			Nat						External Static Pressure Inches of W. C.					
			Input (MBTUH)			150/130									CFM @ 230V – Dry Coil (no filter)		
			Output (MBTUH)			119 / 102									TAP LOW MED L MED H HIGH		
			Gas Valve (HSP)			HW									.10 2140 2260 2395 2470		
			Regulation Type			Snap									.20 2095 2205 2335 2400		
			Manifold Pressure			3.5									.30 2040 2145 2270 2325		
			Orifices			43/46									.40 1985 2080 2200 2250		
			Pilot Orifice Size			.018									.50 1920 2015 2125 2170		
			Temp. Rise 0F			35–65									.60 1855 1940 2050 2085		
			Ignition Type			HSP									.70 1780 1865 1965 2000		
			Fan Control (ON/OFF)			TIME									CFM @ 208V – Dry Coil (no filter)		
			Limit Control (MAX)			130									TAP LOW MED L MED H HIGH		
			Heat Anticipator			.58									.10 1915 2090 2310 2380		
															.20 1885 2045 2250 2315		
															.30 1845 1995 2185 2250		
															.40 1805 1945 2125 2185		
												.50 1755 1890 2060 2105					
												.60 1700 1820 1980 2020					
												.70 1640 1750 1905 1940					
Note: Optimum operating charge will produce 15° – 25° F suction line superheat at compressor with 82° F outdoor ambient and 80° F dry bulb (67° F wet bulb) indoor temperature at rated airflow.										1067989							
										9–22–94							
										AH-1							

Technical Service Data Sheet 7212097-A

					208/230 VOLT - 1 Phase - 60 HZ DIRECT DRIVE										
		MODELS			PGMD	18G040	24G060	24G075	30G060	30G075	36G060	36G075	36G095		
COOLING	TOTAL BTUH (1)					18,000	24,000	24,000	30,000	30,000	34,200	34,200	34,200		
	SENSIBLE BTUH					13,500	18,000	18,000	22,500	22,500	26,000	26,000	26,000		
	LATENT BTUH					4,500	6,000	6,000	7,500	7,500	8,200	8,200	8,200		
	SEER (2)					10.05	10.05	10.05	10.05	10.05	10.05	10.05	10.05	10.05	
GAS HEATING OPTION	INPUT BTUH	OUTPUT BTUH	AFUE % (2)	CALIF CSE											
	40,000	31,000	80.0	75.2	X										
	60,000	47,000	80.0	76.8		X		X		X					
	75,000	59,000	80.0	76.7			X		X			X			
	90,000	71,000	80.0	75.8			(5)		(5)			(5)			
	95,000	73,000	80.0	76.7										X	
	115,000	90,000	80.0	75.2										(5)	
TEMPERATURE RISE					45-75	45-75	45-75	45-75	45-75	30 - 60	45-75	45-75			
TYPE GAS / STAGE					NAT GAS / 1										
MIN / MAX VOLTAGE RANGE					197 / 253										
MIN. CIRCUIT AMPACITY					14.00	16.80	17.00	21.60	21.60	29.25	29.25	31.25			
RECOMD. OVER CURRENT DEVICE					20	25	25	35	35	45	45	45			
COMPRESSOR	TYPE / QTY. RLA				RECIPROCATING / 1										
					9.4	11.2	11.2	14.4	14.4	19.4	19.4	19.4			
EVAPORATOR COIL	FACE AREA SQ. FT.				3.56	3.56	3.56	3.56	3.56	3.56	3.56	3.56			
	FINS PER INCH / NO. OF ROWS				14 / 2	14 / 3	14 / 3	15 / 3	15 / 3	14 / 4	14 / 4	14 / 3			
	COIL MATERIAL				COPPER TUBE ALUMINUM FIN										
EVAP. BLOWER AND MOTOR	REFRIG. CONTROL				CAPTUBE METERING DEVICE										
	DIA. x WIDTH				10 x 6	10 x 6	10 x 8	10 x 8	10 x 8	11 x 8	11 x 8	11 x 9			
	DIRECT DRIVE	HP			1/8	1/4	1/3	1/3	1/3	1/2	1/2	3/4			
TYPE			PSC	PSC	PSC	PSC	PSC	PSC	PSC	PSC					
CONDENSER COIL	FLA (3)				1.5	2.1	2.3	2.3	2.3	3.6	3.6	5.6			
	FACE AREA SQ. FT.				8.35	8.35	8.35	11.47	11.47	11.47	11.47	11.47			
	FINS PER INCH / NO. OF ROWS				20 / 1	20 / 1	20 / 1	20 / 1	20 / 1	20 / 1	20 / 1	20 / 1			
CONDENSER FAN	COIL MATERIAL				COPPER TUBE / ALUMINUM FIN										
	DIA. (INCHES)				20	20	20	20	20	20	20	20			
CONDENSER FAN MOTOR	QUANTITY / NO. OF BLADES				1 / 4	1 / 4	1 / 4	1 / 4	1 / 4	1 / 4	1 / 4	1 / 4			
	HP				1/6	1/6	1/6	1/3	1/3	1/3	1/3	1/3			
COND. DRAIN	RPM				1145	1145	1145	1135	1135	1135	1135	1135			
	FLA (3)				0.8	0.8	0.8	1.4	1.4	1.4	1.4	1.4			
AIR FILTER	SIZE - OD			3/4	3/4	3/4	3/4	3/4	3/4	3/4	3/4	3/4			
OPERATING WEIGHT (LBS)	RECOM. AREA/SQ. IN		PERM. DISPOS.		320	320	320	400	400	576	576	576			
					400	400	400	500	500	480	480	480			
REFRIG. CHARGE	R-22 / OZ.				400										
						410		425		435					
							410		425		435				
													435		

- (1) BASED ON 80 F DB, 67 F WB ON EVAPORATOR COIL, 95 F AMBIENT ON CONDENSER & 230 VOLT SUPPLY. (208V MULTIPLIER .98)
- (2) DOE PRESCRIBED TEST METHOD
- (3) NAME PLATE AMPS ARE BASED ON THE RATED SPEED LISTED. HIGHER OR LOWER AMP DRAW COULD OCCUR.
- (4) AIR FILTERS IN RETURN DUCT SUPPLIED BY CONTRACTOR FOR 2 THRU 3 1/2 TON. INTERNAL FILTER RACK LESS FILTER SUPPLIED ON 4 - 5 TON.
- (5) ALTERNATE HEAT INPUT USING INPUT ADJUSTMENT KIT (FIELD INSTALLED ONLY) P. N. ZAXB023ILP.

CONTINUING ENGINEERING RESEARCH RESULTS IN STEADY IMPROVEMENT THEREFORE THESE SPECIFICATIONS ARE SUBJECT TO CHANGE WITHOUT NOTICE. ALWAYS CONSULT EQUIPMENT NAMEPLATE FOR EXACT ELECTRICAL REQUIREMENTS.

Technical Service Data Sheet 7212097-B

MODELS		PGMD	42G115	48G090	48G135	60G115	60G150
COOLING	TOTAL BTUH (1)		40,000	46,000	46,000	58,500	58,500
	SENSIBLE BTUH		30,400	34,500	34,500	43,875	43,875
	LATENT BTUH		10,000	11,500	11,500	14,625	14,625
	SEER (2)		10.05	10.05	10.05	10.05	10.05
GAS HEATING OPTION	INPUT BTUH	OUTPUT BTUH	AFUE % (2)	CALIF CSE			
	75,000	60,000	80.0	76.2		(5)	
	90,000	71,000	80.0	75.8		X	
	95,000	75,000	80.0	75.2	(5)		
	110,000	87,000	80.0	76.9		(6)	
	115,000	90,000	80.0	77.0	X		X
	135,000	106,000	80.0	76.1		X	(7)
	150,000	119,000	80.0	75.7			X
	TEMPERATURE RISE			45-75	30-60	35-65	30-60
TYPE GAS / STAGE			NAT / 1				
MIN / MAX VOLTAGE RANGE			197 / 253				
MIN. CIRCUIT AMPACITY			31.80	35.80	36.00	43.70	44.70
RECOMD. OVER CURRENT DEVICE			50	50	50	70	70
COMPRESSOR	TYPE / QTY.		SCROLL / 1				
	RLA		19.9	23.7	23.7	34.0	35.1
EVAPORATOR COIL	FACE AREA SQ. FT.		3.56	8.22	8.22	8.22	8.22
	FINS PER INCH / NO. OF ROWS		14 / 4	15 / 2	15 / 2	14 / 3	14 / 3
	COIL MATERIAL		COPPER TUBE / ALUMINUM FINNS				
	REFRIG. CONTROL		CAPILLARY TUBE METERING DEVICE				
EVAP. BLOWER AND MOTOR	DIA. x WIDTH		11 x 9	10 x 9	11 x 11	11 x 11	11 x 11
	DIRECT DRIVE	HP	3/4	1/2	1.0	1.0	1.0
		TYPE	PSC	PSC	PSC	PSC	PSC
		FLA (3)	5.6	4.4	4.6	5.0	6.0
CONDENSER COIL	FACE AREA SQ. FT.		11.47	17.2	17.2	17.2	17.2
	FINS PER INCH / NO. OF ROWS		20 / 1	20 / 1	20 / 1	20 / 1	20 / 1
	COIL MATERIAL		COPPER TUBE / ALUMNUM FINNS				
CONDENSER FAN	DIA. (INCHES)		20	22	22	22	22
	QUANTITY / NO OF BLADES		1 / 4	1 / 4	1 / 4	1 / 4	1 / 4
CONDENSER FAN MOTOR	HP		1/3	1/2	1/2	3/4	3/4
	RPM		1135	1155	1155	1155	1155
	FLA (3)		1.4	1.8	1.8	2.6	2.6
COND. DRAIN	SIZE - OD		3/4	3/4	3/4	3/4	3/4
AIR (4) FILTER	RECOM. AREA/SQ. IN	PERM.	505	461	461	576	576
		DISPOS.	680	768	768	960	960
OPERATING WEIGHT (LBS.)	90,000		450	600			
	115,000					625	
	135,000				610		
	150,000						630
REFRIG. CHARGE	R-22 / OZ.		82	129	129	122	122

(1) BASED ON 80 F. DB, 67 F. WB ON EVAPORATOR, 95 F. AMBIENT ON CONDENSER & 230VOLT 1 PHASE VOLT SUPPLY.(208V MULTIPLIER .98).

(2) DOE PRESCRIBED TEST METHOD.

(3) NAME PLATE AMPS ARE BASED ON THE RATED SPEED LISTED.HIGHER OR LOWER AMP DRAW COULD OCCUR.

(4) AIR FILTERS IN RETURN DUCT SUPPLIED BY CONTRACTOR FOR 2 THRU 3 1/2 TON. INTERNAL FILTER RACK LESS FILTER SUPPLIED ON 4 - 5 TON.

(5) ALTERNATE HEAT INPUT USING ADJUSTMENT KIT (FIELD INSTALLED ONLY). P.N. ZAXB023ILP

(6) ALTERNATE INPUT FOR PGME48G135 = 110,00 BTUH. (KIT NO. ZAXB023ILP)

(7) ALTERNATE INPUT FOR PGME60G150 = 130,000 BTUH. (KIT NO. ZAXB023ILP)

CONTINUING ENGINEERING RESEARCH RESULTS IN STEADY IMPROVEMENT THEREFORE THESE SPECIFICATIONS

ARE SUBJECT TO CHANGE WITHOUT NOTICE. ALWAYS CONSULT EQUIPMENT NAMEPLATE FOR EXACT ELECTRICAL REQUIREMENTS.

Technical Service Data Sheet 7212097-C

					208/230 VOLT - 1 Phase - 60 HZ DIRECT DRIVE				
MODELS				PGME	24G040	24G075	30G075	36G075	36G095
COOLING	TOTAL BTUH (1)				23,800	23,800	29,800	34,200	34,200
	SENSIBLE BTUH				17,850	17,850	22,052	25,310	25,310
	LATENT BTUH				5,950	5,950	7,748	8,892	8,892
	SEER (2)				12.05	12.05	12.05	12.05	12.05
GAS HEATING OPTION	INPUT BTUH	OUTPUT BTUH	AFUE % (2)	CALIF CSE					
	40,000	31,000	80.0	74.8	X				
	75,000	59,000	80.0	76.7		X	X	X	
	90,000	71,000	80.0	75.8		(5)	(5)	(5)	
	95,000	73,000	80.0	76.7					X
	115,000	90,000	80.0	75.2					(5)
TEMPERATURE RISE					30-60	45-75	45-75	45-75	45-75
TYPE GAS / STAGE					NAT GAS / 1				
MIN / MAX VOLTAGE RANGE					197 / 253				
MIN. CIRCUIT AMPACITY					17.9	18.1	20.5	27.4	27.4
RECOMD. OVER CURRENT DEVICE					25	25	30	45	45
COMPRESSOR	TYPE / QTY. RLA				SCROLL / 1				
					11.5	11.5	13.5	17.9	17.9
EVAPORATOR COIL	FACE AREA SQ. FT.				3.56	3.56	3.58	3.56	3.56
	FINS PER INCH/NO. OF ROWS				14 / 3	14 / 3	14 / 4	14 / 4	14 / 4
	COIL MATERIAL				COPPER TUBE ALUMINUM FIN				
	REFRIG. CONTROL				THERMAL EXPANSION VALVE				
EVAP. BLOWER AND MOTOR	DIA. x WIDTH				10 x 6	10 x 8	10 x 8	11 x 9	11 x 9
	DIRECT DRIVE	TYPE			1/4	1/3	1/3	1/2	1/2
		FLA (3)			PSC	PSC	PSC	PSC	PSC
		HP			2.1	2.3	2.3	3.6	3.6
CONDENSER COIL	FACE AREA SQ. FT.				11.47	11.47	11.47	11.47	11.47
	FINS PER INCH / NO. OF ROWS				20 / 1	20 / 1	20 / 1	20 / 1	20 / 1
	COIL MATERIAL				COPPER TUBE ALUMINUM FIN				
CONDENSER FAN	DIA. (INCHES)				20	20	20	20	20
	QUANTITY / NO. OF BLADES				1 / 4	1 / 4	1 / 4	1 / 4	1 / 4
CONDENSER FAN MOTOR	HP				1/3	1/3	1/3	1/3	1/3
	RPM				1145	1145	1145	1145	1145
	FLA (3)				1.4	1.4	1.4	1.4	1.4
COND. DRAIN	SIZE - OD				3/4	3/4	3/4	3/4	3/4
AIR (4) FILTER	RECOM.		PERM.		246	246	301	356	356
	AREA/SQ. IN		DISPOS.		400	400	487	576	576
OPERATING WEIGHT (LBS)	40,000				396	401			
	75,000						412	422	
	95,000								427
REFRIG. CHARGE	R-22 / OZ.				73	73	78	78	78

(1) BASED ON 80 F DB, 67 F WB ON EVAPORATOR COIL, 95 F AMBIENT ON CONDENSER & 230 VOLT SUPPLY. (208V MULTIPLIER .98)

(2) DOE PRESCRIBED TEST METHOD

(3) NAME PLATE AMPS ARE BASED ON THE RATED SPEED LISTED. HIGHER OR LOWER AMP DRAW COULD OCCUR.

(4) AIR FILTERS IN RETURN DUCT SUPPLIED BY CONTRACTOR FOR 2 THRU 3 TON. INTERNAL FILTER RACK LESS FILTER SUPPLIED ON 3.5 - 5 TON.

(5) ALTERNATE HEAT INPUT USING INPUT ADJUSTMENT KIT (FIELD INSTALLED ONLY) P.N. ZAXB023ILP

CONTINUING ENGINEERING RESEARCH RESULTS IN STEADY IMPROVEMENT THEREFORE THESE SPECIFICATIONS ARE SUBJECT TO CHANGE WITHOUT NOTICE. ALWAYS CONSULT EQUIPMENT NAMEPLATE FOR EXACT ELECTRICAL REQUIREMENTS.

Technical Service Data Sheet 7212097-D

MODELS					208/230 VOLT - 1 Phase - 60 HZ. DIRECT DRIVE					
					PGME	42G075	42G115	48G090	48G135	60G115
COOLING	TOTAL BTUH (1)				40,000	40,000	47,500	47,500	58,000	58,000
	SENSIBLE BTUH				30,800	30,800	37,050	37,050	42,340	42,340
	LATENT BTUH				9,200	9,200	10,450	10,450	15,660	15,660
	SEER (2)				12.05	12.05	12.05	12.05	12.05	12.05
GAS HEATING OPTION	INPUT BTUH	OUTPUT BTUH	AFUE % (2)	CALIF CSE						
	75,000	60,000	80.0	76.7	X		(5)			
	90,000	71,000	80.0	75.8	(5)		X			
	95,000	73,000	80.0	76.7		(5)			(5)	
	110,000	87,000	80.0	76.9				(6)		
	115,000	90,000	80.0	75.2		X			X	
	135,000	106,000	80.0	76.1				X		(7)
	150,000	119,000	80.0	76.0						X
TEMPERATURE RISE					30-60	35-65	30-60	35-65	30-60	35-65
TYPE GAS / STAGE					NAT. GAS / 1					
MIN / MAX VOLTAGE RANGE					197 / 253					
MIN. CIRCUIT AMPACITY					31.0	31.0	35.8	36.0	42.9	43.9
RECOMD. OVER CURRENT DEVICE					50	50	50	50	70	70
COMPRESSOR	TYPE / QTY. RLA				SCROLL / 1					
					19.9	19.9	23.7	23.7	28.8	28.8
EVAPORATOR COIL	FACE AREA SQ. FT.				8.22	8.22	8.22	8.22	8.22	8.22
	FINS PER INCH / NO. OF ROWS				14 / 3	14 / 3	14 / 3	14 / 3	14 / 4	14 / 4
	COIL MATERIAL				COPPER TUBE ALUMINUM FIN					
	REFRIG. CONTROL				THERMAL EXPANSION VALVE					
EVAP BLOWER AND MOTOR	DIA. x WIDTH				10 x 9	10 x 9	10 x 9	11 x 11	11 x 11	11 x 11
	DIRECT DRIVE	HP			1/2	1/2	1/2	1.0	1.0	1.0
		TYPE			PSC	PSC	PSC	PSC	PSC	PSC
		FLA (3)			4.4	4.4	4.4	4.6	5.0	6.0
CONDENSER COIL	FACE AREA SQ. FT.				17.2	17.2	17.2	17.2	17.2	17.2
	FINS PER INCH / NO. OF ROWS				20 / 2	20 / 2	20 / 2	20 / 2	20 / 2	20 / 2
	COIL MATERIAL				COPPER TUBE ALUMINUM FIN					
CONDENSER FAN	DIA. (INCHES)				22	22	22	22	22	22
	QUANTITY / NO. OF BLADES				1 / 4	1 / 4	1 / 4	1 / 4	1 / 4	1 / 4
CONDENSER FAN MOTOR	HP				1/2	1/2	1/2	1/2	1/2	1/2
	RPM				1145	1145	1145	1145	1145	1145
	FLA (3)				1.8	1.8	1.8	1.8	1.8	1.8
COND. DRAIN	SIZE - OD				3/4	3/4	3/4	3/4	3/4	3/4
AIR (4) FILTER	RECOM. AREA/SQ. IN		PERM. DISPOS.		411	411	466	466	575	575
					665	665	753	753	960	960
OPERATING WEIGHT (LBS.)	75,000				562					
	90,000						582			
	115,000					567			612	
	135,000							590		
	150,000									617
REFRIG. CHARGE	R-22 / OZ.				180	180	215	215	215	215

(1) BASED ON 80 F. DB, 67 F. WB ON EVAPORATOR, 95 F. AMBIENT ON CONDENSER & 230 VOLT 1 PHASE VOLT SUPPLY. (208V MULTIPLIER .98).

(2) DOE PRESCRIBED TEST METHOD.

(3) NAME PLATE AMPS ARE BASED ON THE RATED SPEED LISTED. HIGHER OR LOWER AMP DRAW COULD OCCUR.

(4) AIR FILTERS IN RETURN DUCT SUPPLIED BY CONTRACTOR FOR 2 THRU 3 TON. INTERNAL FILTER RACK LESS FILTER SUPPLIED ON 3 1/2 - 5 TON.

(5) ALTERNATE HEAT INPUT USING ADJUSTMENT KIT (FIELD INSTALLED ONLY) P. N. ZAXB023ILP.

(6) ALTERNATE INPUT FOR PGME48G135 = 110,00 BTUH. (KIT NO. ZAXB023ILP)

(7) ALTERNATE INPUT FOR PGME60G150 = 130,000 BTUH. (KIT NO. ZAXB023ILP)

CONTINUING ENGINEERING RESEARCH RESULTS IN STEADY IMPROVEMENT THEREFORE THESE SPECIFICATIONS

ARE SUBJECT TO CHANGE WITHOUT NOTICE. ALWAYS CONSULT EQUIPMENT NAMEPLATE FOR EXACT ELECTRICAL REQUIREMENTS.

Technical Service Data Sheet 7212109-A

					208/230 VOLT - 1 Phase - 60 HZ DIRECT DRIVE								
COOLING	MODELS				PGMD	18G040	24G060	24G075	30G060	30G075	36G060	36G075	36G095
	TOTAL BTUH (1)					18,000	24,000	24,000	30,000	30,000	34,200	34,200	34,200
	SENSIBLE BTUH					13,500	18,000	18,000	22,500	22,500	26,000	26,000	26,000
	LATENT BTUH					4,500	6,000	6,000	7,500	7,500	8,200	8,200	8,200
SEER (2)					10.05	10.05	10.05	10.05	10.05	10.05	10.05	10.05	
GAS HEATING OPTION	INPUT BTUH	OUTPUT BTUH	AFUE % (2)	CALIF CSE									
	40,000	31,000	80.0	75.2	X								
	60,000	47,000	80.0	76.8		X		X		X			
	75,000	59,000	80.0	76.7			X		X		X		
	90,000	71,000	80.0	75.8			(5)		(5)		(5)		
	95,000	73,000	80.0	76.7								X	
115,000	90,000	80.0	75.2									(5)	
TEMPERATURE RISE					45-75	45-75	45-75	45-75	45-75	30 - 60	45-75	45-75	
TYPE GAS / STAGE					NAT GAS / 1								
MIN / MAX VOLTAGE RANGE					197 / 253								
MIN. CIRCUIT AMPACITY					14.00	16.80	17.00	21.60	21.60	29.25	29.25	31.25	
RECOMD. OVER CURRENT DEVICE					20	25	25	35	35	45	45	45	
COMPRESSOR	TYPE / QTY. RLA				RECIPROCATING / 1								
					9.4	11.2	11.2	14.4	14.4	19.4	19.4	19.4	
EVAPORATOR COIL	FACE AREA SQ. FT.				3.56	3.56	3.56	3.56	3.56	3.56	3.56	3.56	
	FINS PER INCH / NO. OF ROWS				14 / 2	14 / 3	14 / 3	15 / 3	15 / 3	14 / 4	14 / 4	14 / 3	
	COIL MATERIAL				COPPER TUBE ALUMINUM FIN								
EVAP. BLOWER AND MOTOR	REFRIG. CONTROL				CAPTUBE METERING DEVICE								
	DIA. x WIDTH				10 x 6	10 x 6	10 x 8	10 x 8	10 x 8	11 x 8	11 x 8	11 x 9	
	DIRECT DRIVE	HP			1/8	1/4	1/3	1/3	1/3	1/2	1/2	3/4	
TYPE			PSC	PSC	PSC	PSC	PSC	PSC	PSC	PSC			
FLA (3)				1.5	2.1	2.3	2.3	2.3	3.6	3.6	5.6		
CONDENSER COIL	FACE AREA SQ. FT.				8.35	8.35	8.35	11.47	11.47	11.47	11.47	11.47	
	FINS PER INCH / NO. OF ROWS				20 / 1	20 / 1	20 / 1	20 / 1	20 / 1	20 / 1	20 / 1		
	COIL MATERIAL				COPPER TUBE / ALUMINUM FIN								
CONDENSER FAN	DIA. (INCHES)				20	20	20	20	20	20	20		
	QUANTITY / NO. OF BLADES				1 / 4	1 / 4	1 / 4	1 / 4	1 / 4	1 / 4	1 / 4		
CONDENSER FAN MOTOR	HP				1/6	1/6	1/6	1/3	1/3	1/3	1/3		
	RPM				1145	1145	1145	1135	1135	1135	1135		
	FLA (3)				0.8	0.8	0.8	1.4	1.4	1.4	1.4		
COND. DRAIN	SIZE - OD				3/4	3/4	3/4	3/4	3/4	3/4	3/4		
AIR FILTER	(4)	RECOM. AREA/SQ. IN		PERM. DISPOS.	320	320	320	400	400	576	576	576	
					400	400	400	500	500	480	480	480	
OPERATING WEIGHT (LBS)	40,000				400								
	60,000												
	75,000				410								
	95,000				410								
REFRIG. CHARGE	R-22 / OZ.				57	64	64	75	75	85	85	85	

- (1) BASED ON 80 F DB, 67 F WB ON EVAPORATOR COIL, 95 F AMBIENT ON CONDENSER & 230 VOLT SUPPLY. (208V MULTIPLIER .98)
- (2) DOE PRESCRIBED TEST METHOD
- (3) NAME PLATE AMPS ARE BASED ON THE RATED SPEED LISTED. HIGHER OR LOWER AMP DRAW COULD OCCUR.
- (4) AIR FILTERS IN RETURN DUCT SUPPLIED BY CONTRACTOR FOR 2 THRU 3 1/2 TON. INTERNAL FILTER RACK LESS FILTER SUPPLIED ON 4 - 5 TON.
- (5) ALTERNATE HEAT INPUT USING INPUT ADJUSTMENT KIT (FIELD INSTALLED ONLY) P. N. ZAXB023ILP.

CONTINUING ENGINEERING RESEARCH RESULTS IN STEADY IMPROVEMENT THEREFORE THESE SPECIFICATIONS ARE SUBJECT TO CHANGE WITHOUT NOTICE. ALWAYS CONSULT EQUIPMENT NAMEPLATE FOR EXACT ELECTRICAL REQUIREMENTS.

Technical Service Data Sheet 7212109-B

MODELS		PGMD	42G115	48G090	48G135	60G115	60G150
COOLING	TOTAL BTUH (1)		40,000	46,000	46,000	58,500	58,500
	SENSIBLE BTUH		30,400	34,500	34,500	43,875	43,875
	LATENT BTUH		10,000	11,500	11,500	14,625	14,625
	SEER (2)		10.05	10.05	10.05	10.05	10.05
GAS HEATING OPTION	INPUT BTUH	OUTPUT BTUH	AFUE % (2)	CALIF CSE			
	75,000	60,000	80.0	76.2		(5)	
	90,000	71,000	80.0	75.8		X	
	95,000	75,000	80.0	75.2	(5)		
	110,000	87,000	80.0	76.9		(6)	
	115,000	90,000	80.0	77.0	X		X
	135,000	106,000	80.0	76.1		X	(7)
	150,000	119,000	80.0	75.7			X
	TEMPERATURE RISE			45-75	30-60	35-65	30-60
TYPE GAS / STAGE			NAT / 1				
MIN / MAX VOLTAGE RANGE			197 / 253				
MIN. CIRCUIT AMPACITY			31.80	35.80	36.00	43.70	44.70
RECOMD. OVER CURRENT DEVICE			50	50	50	70	70
COMPRESSOR	TYPE / QTY.		SCROLL / 1				
	RLA		19.9	23.7	23.7	34.0	35.1
EVAPORATOR COIL	FACE AREA SQ. FT.		3.56	8.22	8.22	8.22	8.22
	FINS PER INCH / NO. OF ROWS		14 / 4	15 / 2	15 / 2	14 / 3	14 / 3
	COIL MATERIAL		COPPER TUBE / ALUMINUM FINS				
	REFRIG. CONTROL		CAPILLARY TUBE METERING DEVICE				
EVAP. BLOWER AND MOTOR	DIA. x WIDTH		11 x 9	10 x 9	11 x 11	11 x 11	11 x 11
	DIRECT DRIVE	HP	3/4	1/2	1.0	1.0	1.0
		TYPE	PSC	PSC	PSC	PSC	PSC
		FLA (3)	5.6	4.4	4.6	5.0	6.0
CONDENSER COIL	FACE AREA SQ. FT.		11.47	17.2	17.2	17.2	17.2
	FINS PER INCH / NO. OF ROWS		20 / 1	20 / 1	20 / 1	20 / 1	20 / 1
	COIL MATERIAL		COPPER TUBE / ALUMNUM FINS				
CONDENSER FAN	DIA. (INCHES)		20	22	22	22	22
	QUANTITY / NO OF BLADES		1 / 4	1 / 4	1 / 4	1 / 4	1 / 4
CONDENSER FAN MOTOR	HP		1/3	1/2	1/2	3/4	3/4
	RPM		1135	1155	1155	1155	1155
	FLA (3)		1.4	1.8	1.8	2.6	2.6
COND. DRAIN	SIZE - OD		3/4	3/4	3/4	3/4	3/4
AIR (4) FILTER	RECOM. AREA/SQ. IN		505	461	461	576	576
	PERM. DISPOS.		680	768	768	960	960
OPERATING WEIGHT (LBS.)	90,000		450	600			
	115,000					625	
	135,000				610		
	150,000						630
REFRIG. CHARGE	R-22 / OZ.		82	129	129	122	122

(1) BASED ON 80 F. DB, 67 F. WB ON EVAPORATOR, 95 F. AMBIENT ON CONDENSER & 230VOLT 1 PHASE VOLT SUPPLY. (208V MULTIPLIER .98).

(2) DOE PRESCRIBED TEST METHOD.

(3) NAME PLATE AMPS ARE BASED ON THE RATED SPEED LISTED. HIGHER OR LOWER AMP DRAW COULD OCCUR.

(4) AIR FILTERS IN RETURN DUCT SUPPLIED BY CONTRACTOR FOR 2 THRU 3 1/2 TON. INTERNAL FILTER RACK LESS FILTER SUPPLIED ON 4 - 5 TON.

(5) ALTERNATE HEAT INPUT USING ADJUSTMENT KIT (FIELD INSTALLED ONLY). P.N. ZAXB023ILP

(6) ALTERNATE INPUT FOR PGME48G135 = 110,00 BTUH. (KIT NO. ZAXB023ILP)

(7) ALTERNATE INPUT FOR PGME60G150 = 130,000 BTUH. (KIT NO. ZAXB023ILP)

CONTINUING ENGINEERING RESEARCH RESULTS IN STEADY IMPROVEMENT THEREFORE THESE SPECIFICATIONS

ARE SUBJECT TO CHANGE WITHOUT NOTICE. ALWAYS CONSULT EQUIPMENT NAMEPLATE FOR EXACT ELECTRICAL REQUIREMENTS.

Technical Service Data Sheet 7212109-C

					208/230 VOLT - 1 Phase - 60 HZ DIRECT DRIVE				
MODELS				PGME	24G040	24G075	30G075	36G075	36G095
COOLING	TOTAL BTUH (1)				23,800	23,800	29,800	34,200	34,200
	SENSIBLE BTUH				17,850	17,850	22,052	25,310	25,310
	LATENT BTUH				5,950	5,950	7,748	8,892	8,892
	SEER (2)				12.05	12.05	12.05	12.05	12.05
GAS HEATING OPTION	INPUT BTUH	OUTPUT BTUH	AFUE % (2)	CALIF CSE					
	40,000	31,000	80.0	74.8	X				
	75,000	59,000	80.0	76.7		X	X	X	
	90,000	71,000	80.0	75.8		(5)	(5)	(5)	
	95,000	73,000	80.0	76.7					X
	115,000	90,000	80.0	75.2					(5)
TEMPERATURE RISE					30-60	45-75	45-75	45-75	45-75
TYPE GAS / STAGE					NAT GAS / 1				
MIN / MAX VOLTAGE RANGE					197 / 253				
MIN. CIRCUIT AMPACITY					17.9	18.1	20.5	27.4	27.4
RECOMD. OVER CURRENT DEVICE					25	25	30	45	45
COMPRESSOR	TYPE / QTY. RLA				SCROLL / 1				
					11.5	11.5	13.5	17.9	17.9
EVAPORATOR COIL	FACE AREA SQ. FT.				3.56	3.56	3.58	3.56	3.56
	FINS PER INCH/NO. OF ROWS				14 / 3	14 / 3	14 / 4	14 / 4	14 / 4
	COIL MATERIAL				COPPER TUBE ALUMINUM FIN				
	REFRIG. CONTROL				THERMAL EXPANSION VALVE				
EVAP. BLOWER AND MOTOR	DIA. x WIDTH				10 x 6	10 x 8	10 x 8	11 x 9	11 x 9
	DIRECT DRIVE	TYPE			1/4	1/3	1/3	1/2	1/2
		FLA (3)			PSC	PSC	PSC	PSC	PSC
		HP			2.1	2.3	2.3	3.6	3.6
CONDENSER COIL	FACE AREA SQ. FT.				11.47	11.47	11.47	11.47	11.47
	FINS PER INCH / NO. OF ROWS				20 / 1	20 / 1	20 / 1	20 / 1	20 / 1
	COIL MATERIAL				COPPER TUBE ALUMINUM FIN				
CONDENSER FAN	DIA. (INCHES)				20	20	20	20	20
	QUANTITY / NO. OF BLADES				1 / 4	1 / 4	1 / 4	1 / 4	1 / 4
CONDENSER FAN MOTOR	HP				1/3	1/3	1/3	1/3	1/3
	RPM				1145	1145	1145	1145	1145
COND. DRAIN	FLA (3)				1.4	1.4	1.4	1.4	1.4
	SIZE - OD				3/4	3/4	3/4	3/4	3/4
AIR (4) FILTER	RECOM. AREA/SQ. IN		PERM. DISPOS.		246	246	301	356	356
					400	400	487	576	576
OPERATING WEIGHT (LBS)	40,000				396	401			
	75,000						412	422	
	95,000								427
REFRIG. CHARGE	R-22 / OZ.				73	73	78	78	78

(1) BASED ON 80 F DB, 67 F WB ON EVAPORATOR COIL, 95 F AMBIENT ON CONDENSER & 230 VOLT SUPPLY. (208V MULTIPLIER .98)

(2) DOE PRESCRIBED TEST METHOD

(3) NAME PLATE AMPS ARE BASED ON THE RATED SPEED LISTED. HIGHER OR LOWER AMP DRAW COULD OCCUR.

(4) AIR FILTERS IN RETURN DUCT SUPPLIED BY CONTRACTOR FOR 2 THRU 3 TON. INTERNAL FILTER RACK LESS FILTER SUPPLIED ON 3.5 - 5 TON.

(5) ALTERNATE HEAT INPUT USING INPUT ADJUSTMENT KIT (FIELD INSTALLED ONLY) P.N. ZAXB023ILP

CONTINUING ENGINEERING RESEARCH RESULTS IN STEADY IMPROVEMENT THEREFORE THESE SPECIFICATIONS ARE SUBJECT TO CHANGE WITHOUT NOTICE. ALWAYS CONSULT EQUIPMENT NAMEPLATE FOR EXACT ELECTRICAL REQUIREMENTS.

Technical Service Data Sheet 7212109-D

MODELS					208/230 VOLT - 1 Phase - 60 HZ. DIRECT DRIVE					
					PGME	42G075	42G115	48G090	48G135	60G115
COOLING	TOTAL BTUH (1)				40,000	40,000	47,500	47,500	58,000	58,000
	SENSIBLE BTUH				30,800	30,800	37,050	37,050	42,340	42,340
	LATENT BTUH				9,200	9,200	10,450	10,450	15,660	15,660
	SEER (2)				12.05	12.05	12.05	12.05	12.05	12.05
GAS HEATING OPTION	INPUT BTUH	OUTPUT BTUH	AFUE % (2)	CALIF CSE						
	75,000	60,000	80.0	76.7	X		(5)			
	90,000	71,000	80.0	75.8	(5)		X			
	95,000	73,000	80.0	76.7		(5)			(5)	
	110,000	87,000	80.0	76.9				(6)		
	115,000	90,000	80.0	75.2		X			X	
	135,000	106,000	80.0	76.1				X		(7)
	150,000	119,000	80.0	76.0						X
TEMPERATURE RISE					30-60	35-65	30-60	35-65	30-60	35-65
TYPE GAS / STAGE					NAT. GAS / 1					
MIN / MAX VOLTAGE RANGE					197 / 253					
MIN. CIRCUIT AMPACITY					31.0	31.0	35.8	36.0	42.9	43.9
RECOMD. OVER CURRENT DEVICE					50	50	50	50	70	70
COMPRESSOR	TYPE / QTY. RLA				SCROLL / 1					
					19.9	19.9	23.7	23.7	28.8	28.8
EVAPORATOR COIL	FACE AREA SQ. FT.				8.22	8.22	8.22	8.22	8.22	8.22
	FINS PER INCH / NO. OF ROWS				14 / 3	14 / 3	14 / 3	14 / 3	14 / 4	14 / 4
	COIL MATERIAL				COPPER TUBE ALUMINUM FIN					
	REFRIG. CONTROL				THERMAL EXPANSION VALVE					
EVAP BLOWER AND MOTOR	DIA. x WIDTH				10 x 9	10 x 9	10 x 9	11 x 11	11 x 11	11 x 11
	DIRECT DRIVE	HP			1/2	1/2	1/2	1.0	1.0	1.0
		TYPE			PSC	PSC	PSC	PSC	PSC	PSC
		FLA (3)			4.4	4.4	4.4	4.6	5.0	6.0
CONDENSER COIL	FACE AREA SQ. FT.				17.2	17.2	17.2	17.2	17.2	17.2
	FINS PER INCH / NO. OF ROWS				20 / 2	20 / 2	20 / 2	20 / 2	20 / 2	20 / 2
	COIL MATERIAL				COPPER TUBE ALUMINUM FIN					
CONDENSER FAN	DIA. (INCHES)				22	22	22	22	22	22
	QUANTITY / NO. OF BLADES				1 / 4	1 / 4	1 / 4	1 / 4	1 / 4	1 / 4
CONDENSER FAN MOTOR	HP				1/2	1/2	1/2	1/2	1/2	1/2
	RPM				1145	1145	1145	1145	1145	1145
	FLA (3)				1.8	1.8	1.8	1.8	1.8	1.8
COND. DRAIN	SIZE - OD				3/4	3/4	3/4	3/4	3/4	3/4
AIR (4) FILTER	RECOM. AREA/SQ. IN		PERM. DISPOS.		411	411	466	466	575	575
					665	665	753	753	960	960
OPERATING WEIGHT (LBS.)	75,000				562					
	90,000						582			
	115,000					567			612	
	135,000							590		
	150,000									617
REFRIG. CHARGE	R-22 / OZ.				180	180	215	215	215	215

(1) BASED ON 80 F. DB, 67 F. WB ON EVAPORATOR, 95 F. AMBIENT ON CONDENSER & 230 VOLT 1 PHASE VOLT SUPPLY. (208V MULTIPLIER .98).

(2) DOE PRESCRIBED TEST METHOD.

(3) NAME PLATE AMPS ARE BASED ON THE RATED SPEED LISTED. HIGHER OR LOWER AMP DRAW COULD OCCUR.

(4) AIR FILTERS IN RETURN DUCT SUPPLIED BY CONTRACTOR FOR 2 THRU 3 TON. INTERNAL FILTER RACK LESS FILTER SUPPLIED ON 3 1/2 - 5 TON.

(5) ALTERNATE HEAT INPUT USING ADJUSTMENT KIT (FIELD INSTALLED ONLY) P. N. ZAXB023ILP.

(6) ALTERNATE INPUT FOR PGME48G135 = 110,00 BTUH. (KIT NO. ZAXB023ILP)

(7) ALTERNATE INPUT FOR PGME60G150 = 130,000 BTUH. (KIT NO. ZAXB023ILP)

CONTINUING ENGINEERING RESEARCH RESULTS IN STEADY IMPROVEMENT THEREFORE THESE SPECIFICATIONS

ARE SUBJECT TO CHANGE WITHOUT NOTICE. ALWAYS CONSULT EQUIPMENT NAMEPLATE FOR EXACT ELECTRICAL REQUIREMENTS.

WIRING DIAGRAM INDEX

(Diagrams Appear In Numerical Order On Pages Following Index)

MODEL NUMBER	LADDER DIAGRAM	CONNECTION DIAGRAM	MODEL NUMBER	LADDER DIAGRAM	CONNECTION DIAGRAM
AXB ACCESSORY ECONOMIZERS			G6P		
AXB020EC		30503B-W	G6P024A3A1	1065407-A	1065327
AXB020EPD		31503B-W	G6P024A3B1	1065407-A	1065327
AXB020HE		4532403-W	G6P024A3C1	1065407-A	1065327
AXB020HPA		4532503-W	G6P030A3B1	1065407-A	1065327
AXB020HPD		32503B-W	G6P030A3C1	1065407-A	1065327
AXB030EC		30504B-W	G6P036A3B1	1065407-A	1065327
AXB030EM		4531404-W	G6P036A3C1	1065407-A	1065327
AXB030EPA		4531504W	G6P036A3D1	1065407-A	1065327
AXB030EPD		31504B-W			
AXB030HE		4532404-W	PGAA		
AXB030HPA		4532504-W	PGAA18B1K1	1054383-A	1065326
AXB030HPD		32504B-W	PGAA18B1K3	1067903	1067904
			PGAA18C1K1	1054383-A	1065326
			PGAA18C1K3	1067903	1067904
			PGAA24B1K1	1054383-A	1065326
			PGAA24B1K3	1067903	1067904
			PGAA24C1K1	1054383-A	1065326
			PGAA24C1K3	1067903	1067904
			PGAA24D1K1	1054383-A	1065326
			PGAA24D1K3	1067903	1067904
			PGAA29C1K1	1065407	1065327
			PGAA29D1K1	1065407	1065327
			PGAA30C1K1	1054383-A	1065326
			PGAA30C1K3	1067903	1067904
			PGAA30D1K1	1054383-A	1065326
			PGAA30D1K3	1067903	1067904
			PGAA36C1K1	1054383-A	1065326
			PGAA36C1K2	1065525-B	1066307
			PGAA36C1K3	1067903	1067925
			PGAA36D1K1	1065407-A	1065327
			PGAA36D1K2	1065525-B	1066307
			PGAA36D1K3	1067903	1067925
G4P					
G4P018A3A1	1054383-A	1065326			
G4P018A3B1	1054383-A	1065326			
G4P024A3A1	1054383-A	1065326			
G4P024A3B1	1054383-A	1065326			
G4P030A3B1	1054383-A	1065326			
G4P030A3C1	1054383-A	1065326			
G4P036A3C2	1065525-B	1066307			
G4P036A3D2	1065525-B	1066307			
G4P042A3B1	1065407	1065327			
G4P042A3D1	1065407	1065327			
G4P047A3C1	1065525-B	1065521-A			
G4P047A3E1	1065525-B	1065521-A			
G4P060A3D1	1065525-B	1065521-A			
G4P060A3F1	1065525-B	1065521-A			

MODEL NUMBER	LADDER DIAGRAM	CONNECTION DIAGRAM	MODEL NUMBER	LADDER DIAGRAM	CONNECTION DIAGRAM
			PGAD		
PGAA36E1K1	1065407-A	1065327	PGAD24B1K1	1065407-A	1065327
PGAA36E1K2	1065525-B	1066307	PGAD24B1K3	1067917	1067916
PGAA36E1K3	1067903	1067925	PGAD24D1K1	1065407-A	1065327
PGAA42C1K1	1065407-A	1065327	PGAD24D1K3	1067917	1067916
PGAA42C1K3	1067917	1067916	PGAD30D1K1	1065407-A	1065327
PGAA42E1K1	1065407-A	1065327	PGAD30D1K3	1067917	1067916
PGAA42E1K3	1067917	1067916	PGAD36D1K1	1065407-A	1065327
PGAA47D1K1	1065525-B	1065521-A	PGAD36D1K2	1065407-A	1065327
PGAA47D1K3	1067962	1067961	PGAD36D1K3	1067917	1067916
PGAA47F1K1	1065525-B	1065521-A	PGAD36E1K1	1065407-A	1065327
PGAA47F1K3	1067962	1067961	PGAD36E1K3	1067917	1067916
PGAA48D1K1	1065525-B	1065521-A	PGAD42D1K1	1065407-A	1065327
PGAA48D2K1	1065525-B	1065521-A	PGAD42D1K3	1068243	1068244
PGAA48F1K1	1065525-B	1065521-A	PGAD42E1K1	1065407-A	1065327
PGAA48F2K1	1065525-B	1065521-A	PGAD42E1K3	1068243	1068244
PGAA60D1K1	1065525-B	1065521-A	PGAD47D1K1	1065525-B	1065521-A
PGAA60D1K3	1067962	1067961	PGAD47D1K3	1067962	1067961
PGAA60D2K1	1065525-B	1065521-A	PGAD47F1K1	1065525-B	1065521-A
PGAA60E1K1	1065525-B	1065521-A	PGAD47F1K3	1067962	1067961
PGAA60E1K3	1067962	1067961	PGAD60E1K1	1065525-B	1065521-A
PGAA60E2K1	1065525-B	1065521-A	PGAD60E1K3	1067962	1067961
PGAA60G1K1	1065525-B	1065521-A	PGAD60G1K1	1065525-B	1065521-A
PGAA60G1K3	1067962	1067961	PGAD60G1K3	1067962	1067961
PGAA60G2K1	1065525-B	1065521-A			
			PGAB		
PGAB18B1K1	1065407-A	1065327	PGMD		
PGAB18C1K1	1065407-A	1065327			
PGAB24B1K1	1065407-A	1065327	PGMD18G040	1067778	1067779
PGAB24C1K1	1065407-A	1065327	PGMD18G0401	1068002	1068010
PGAB24D1K1	1065407-A	1065327	PGMD18G0402	1068002	1068010
PGAB30C1K1	1065407-A	1065327	PGMD24G060	1067778	1067779
PGAB30D1K1	1065407-A	1065327	PGMD24G0601	1068002	1068010
PGAB36C1K1	1065407-A	1065327	PGMD24G0602	1068002	1068010
PGAB36D1K1	1065407-A	1065327	PGMD24G075	1067778	1067779
PGAB36E1K1	1065407-A	1065327	PGMD24G0751	1068002	1068010
			PGMD24G0752	1068002	1068010

MODEL NUMBER	LADDER DIAGRAM	CONNECTION DIAGRAM	MODEL NUMBER	LADDER DIAGRAM	CONNECTION DIAGRAM
PGMD30G060	1067778	1067779	PGME30G075	1067574	1067575
PGMD30G0601	1068002	1068010	PGME30G0751	1068005	1068014
PGMD30G0602	1068002	1068010	PGME30G0752	1068005	1068014
PGMD30G075	1067778	1067779	PGME36G075	1067574	1067575
PGMD30G0751	1068002	1068010	PGME36G0751	1068005	1068014
PGMD30G0752	1068002	1068010	PGME36G0752	1068005	1068014
PGMD36G060	1067778	1067779	PGME36G095	1067574	1067575
PGMD36G0601	1068002	1068011	PGME36G0951	1068005	1068014
PGMD36G0602	1068002	1068011	PGME36G0952	1068005	1068014
PGMD36G075	1067778	1067779	PGME42G075	1067574	1067575
PGMD36G0751	1068002	1068011	PGME42G0751	1068278	1068279
PGMD36G0752	1068002	1068011	PGME42G0752	1068278	1068279
PGMD36G095	1067778	1067785	PGME42G115	1067574	1067575
PGMD36G0951	1068002	1068011	PGME42G1151	1068278	1068279
PGMD36G0952	1068002	1068011	PGME42G1152	1068278	1068279
PGMD42G115	1068003	1068012	PGME48G090	1067664	1067663
PGMD42G1151	1068003	1068012	PGME48G0901	1068006	1068015
PGMD42G1152	1068003	1068012	PGME48G0902	1068006	1068015
PGMD48G090	1067817	1067818	PGME48G135	1067664	1067663
PGMD48G0901	1068004	1068013	PGME48G1351	1068006	1068015
PGMD48G0902	1068004	1068013	PGME48G1352	1068006	1068015
PGMD48G135	1067817	1067818	PGME60G115	1067664	1067663
PGMD48G1351	1068004	1068013	PGME60G1151	1068006	1068015
PGMD48G1352	1068004	1068013	PGME60G1152	1068006	1068015
PGMD60G115	1067817	1067818	PGME60G150	1067664	1067663
PGMD60G1151	1068004	1068013	PGME60G1501	1068006	1068015
PGMD60G1152	1068004	1068013	PGME60G1502	1068006	1068015
PGMD60G150	1067817	1067818			
PGMD60G1501	1068004	1068013			
PGMD60G1502	1068004	1068013			

PGME

PGME24G040	1067574	1067575
PGME24G0401	1068005	1068014
PGME24G0402	1068005	1068014
PGME24G075	1067574	1067575
PGME24G0751	1068005	1068014
PGME24G0752	1068005	1068014

Wiring Diagram # 1. (Part # 30503B-W)

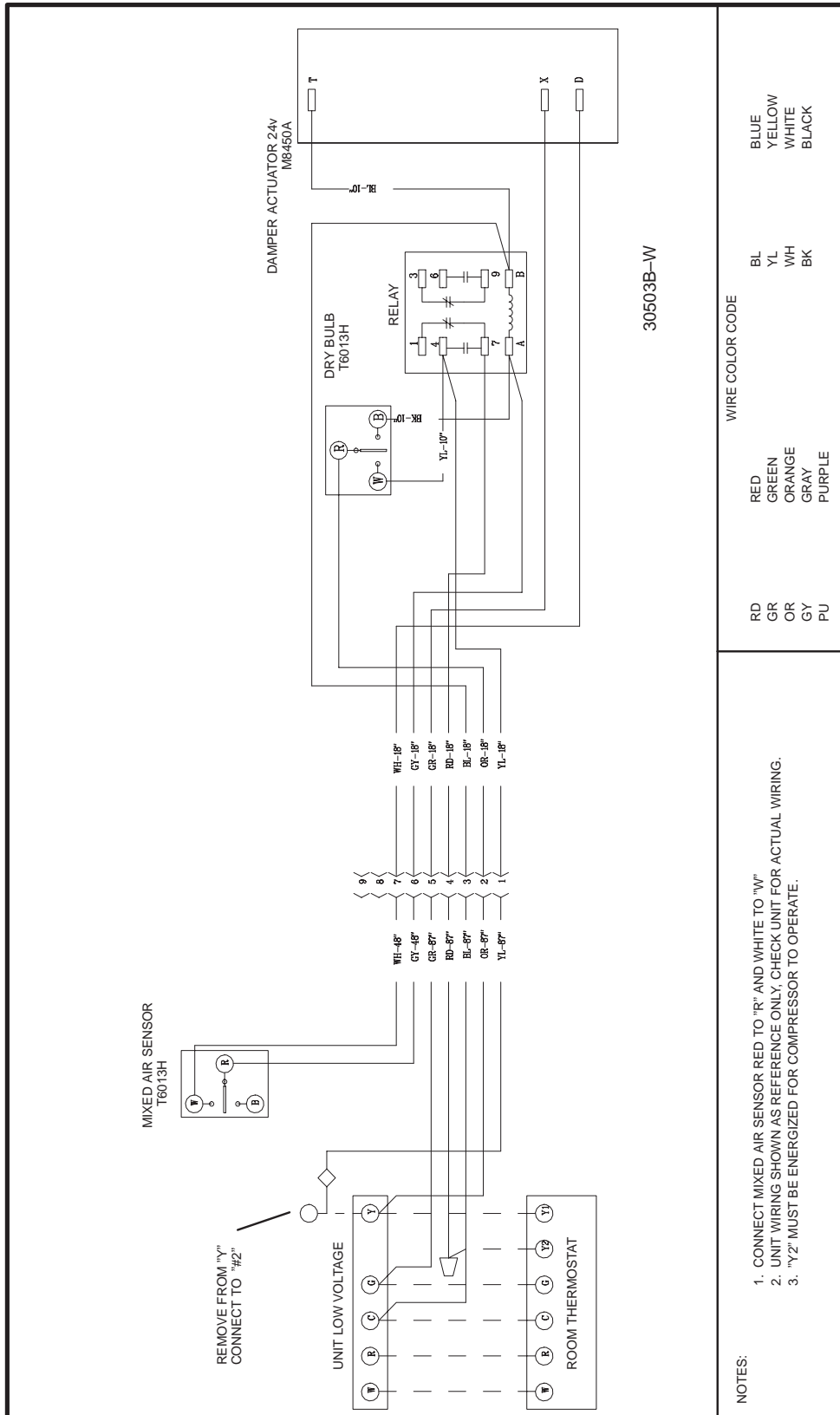

Wiring Diagram # 2. (Part # 30504B-W)

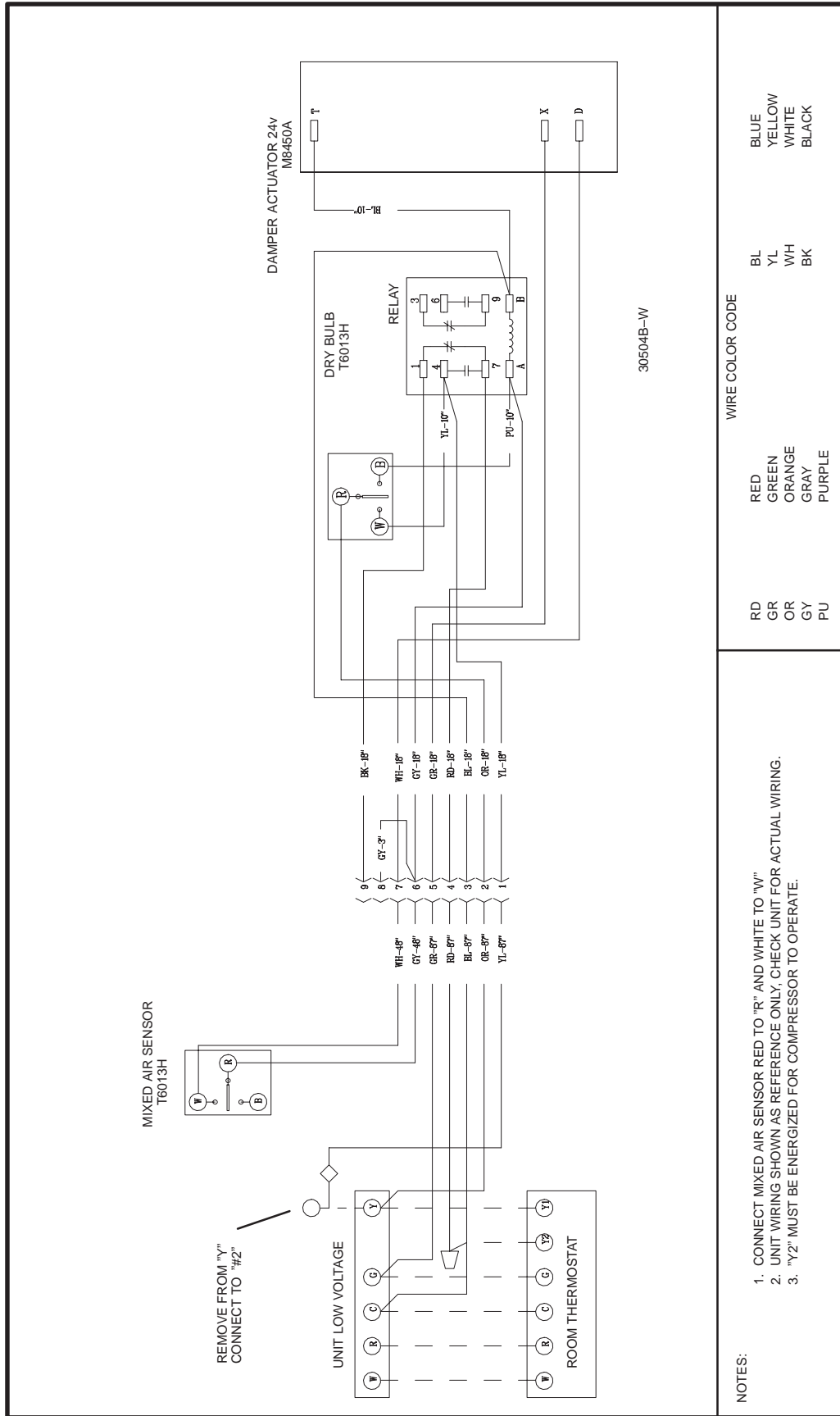

NOTES:
 1. CONNECT MIXED AIR SENSOR RED TO "R" AND WHITE TO "W"
 2. UNIT WIRING SHOWN AS REFERENCE ONLY, CHECK UNIT FOR ACTUAL WIRING.
 3. "Y2" MUST BE ENERGIZED FOR COMPRESSOR TO OPERATE.

Wiring Diagram # 3. (Part # 31503B-W)

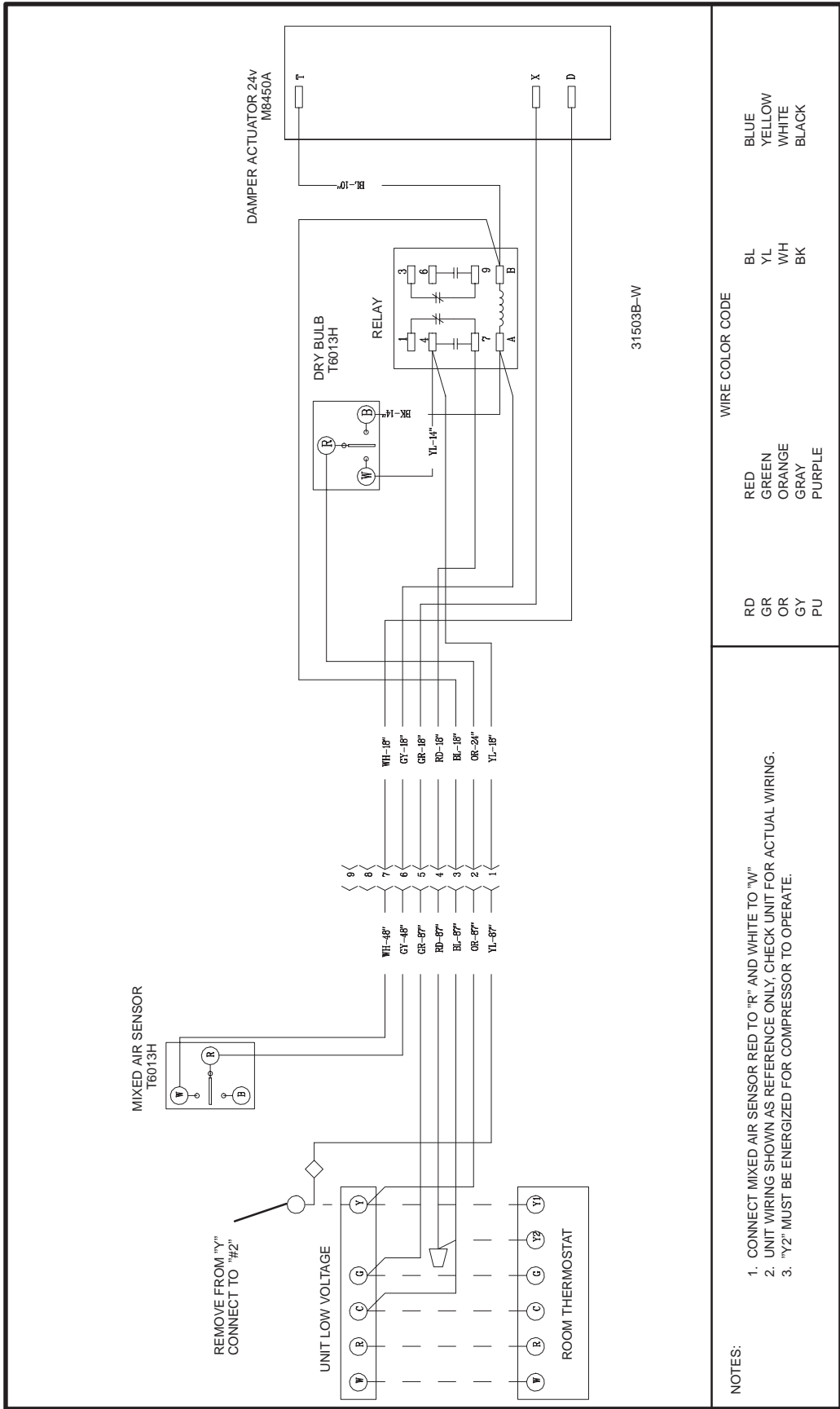

NOTES:
 1. CONNECT MIXED AIR SENSOR RED TO "R" AND WHITE TO "W"
 2. UNIT WIRING SHOWN AS REFERENCE ONLY, CHECK UNIT FOR ACTUAL WIRING.
 3. "Y2" MUST BE ENERGIZED FOR COMPRESSOR TO OPERATE.

Wiring Diagram # 4. (Part # 31504B-W)

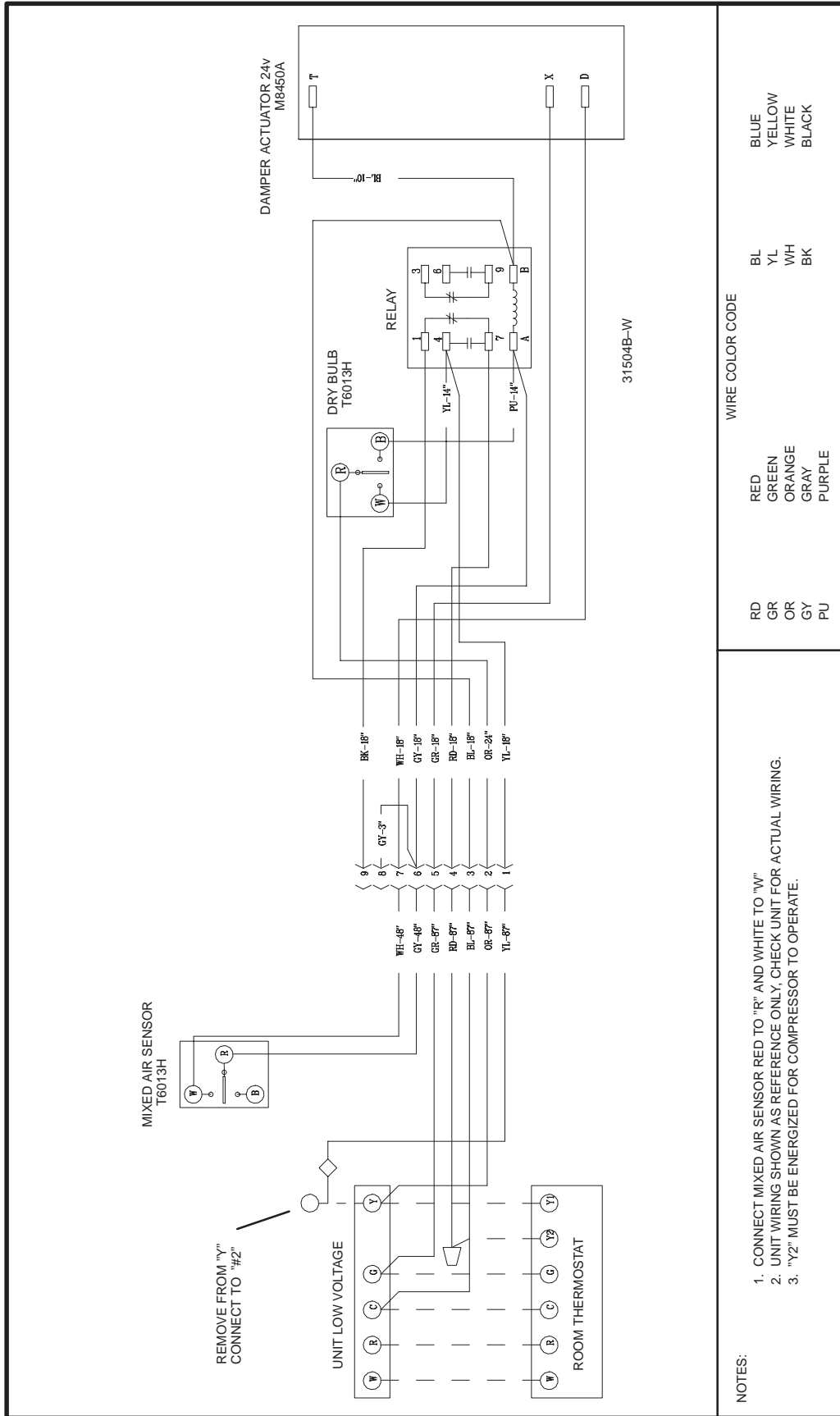

Wiring Diagram # 5. (Part # 32503B-W)

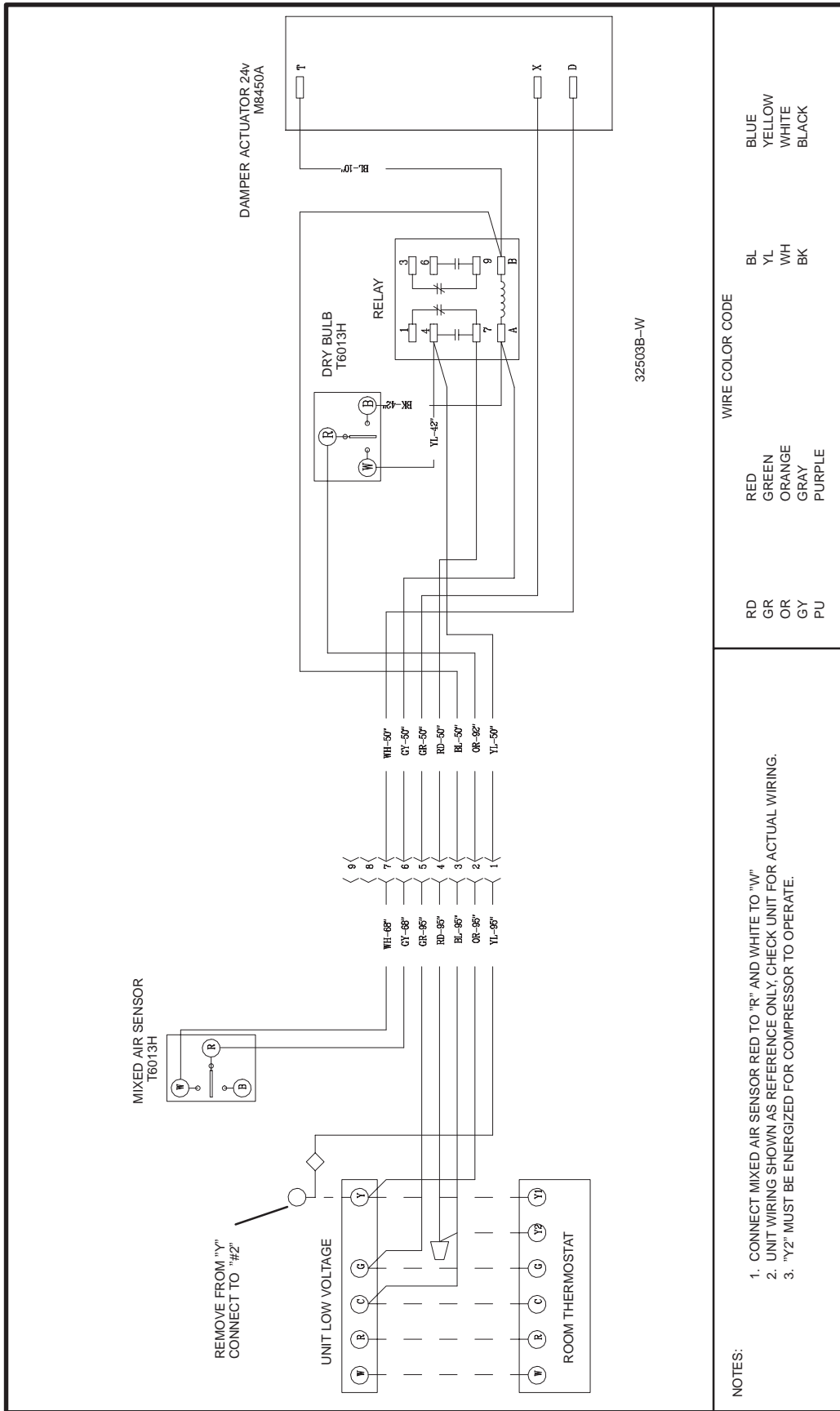

Wiring Diagram # 6. (Part # 32504B-W)

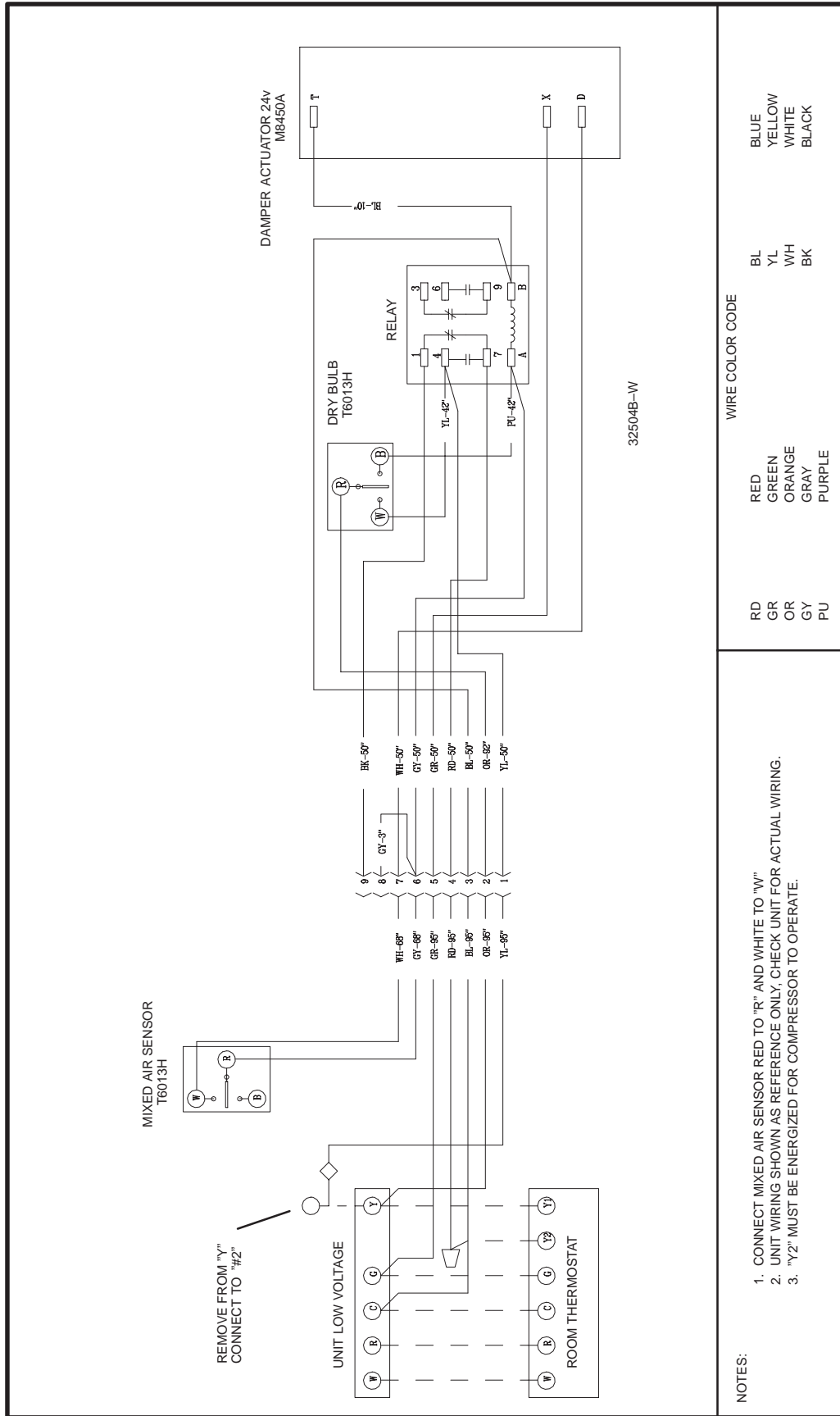

Wiring Diagram # 7. (Part # 1054383-A)

LADDER WIRING DIAGRAM

DANGER: ELECTRICAL SHOCK HAZARD
DISCONNECT POWER BEFORE SERVICING

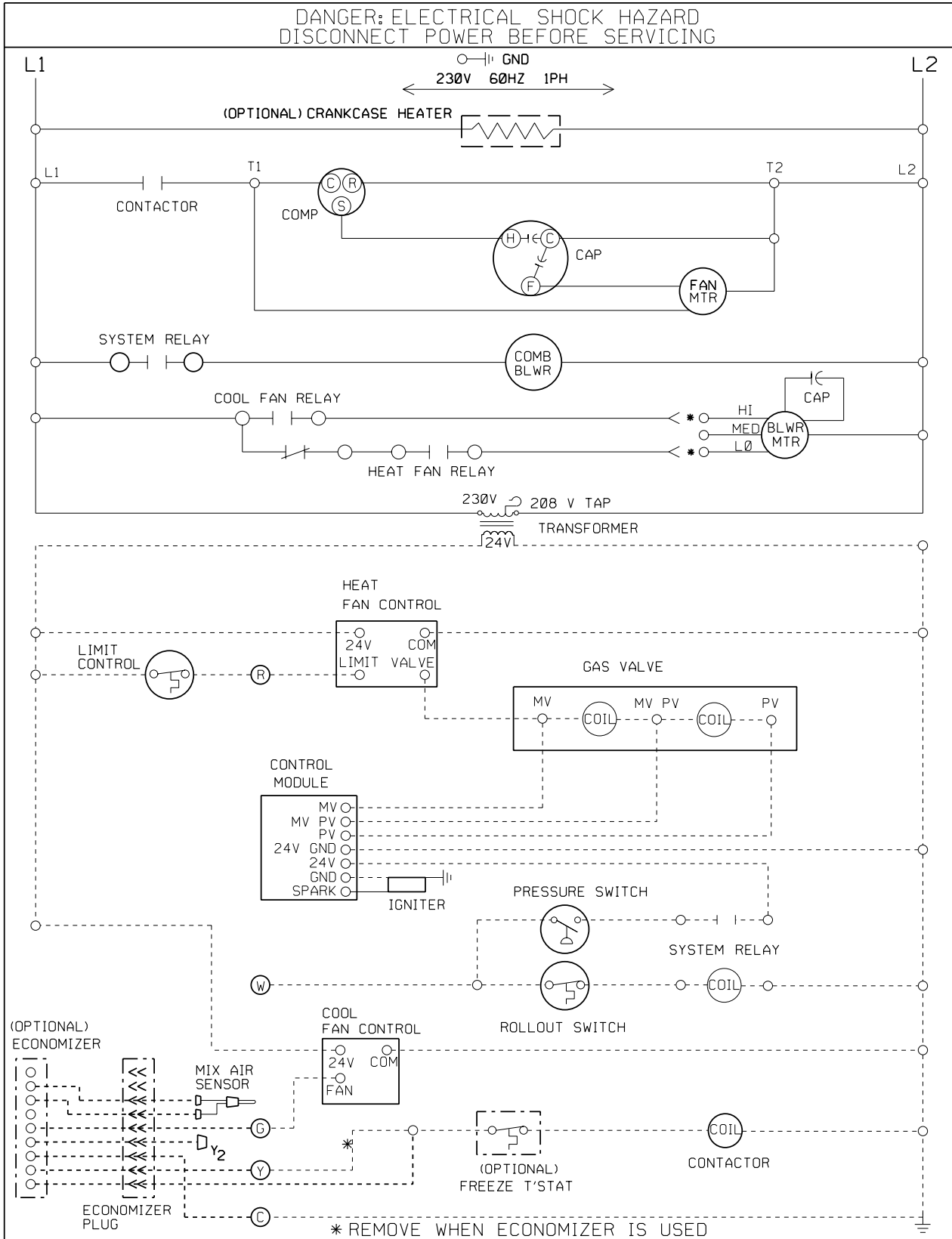

1054383-A

Wiring Diagram # 8. (Part # 1065326)

CONNECTION WIRING DIAGRAM

DANGER: ELECTRICAL SHOCK HAZARD
DISCONNECT POWER BEFORE SERVICING

USE COPPER CONDUCTORS ONLY
208/230V 60HZ 1PH

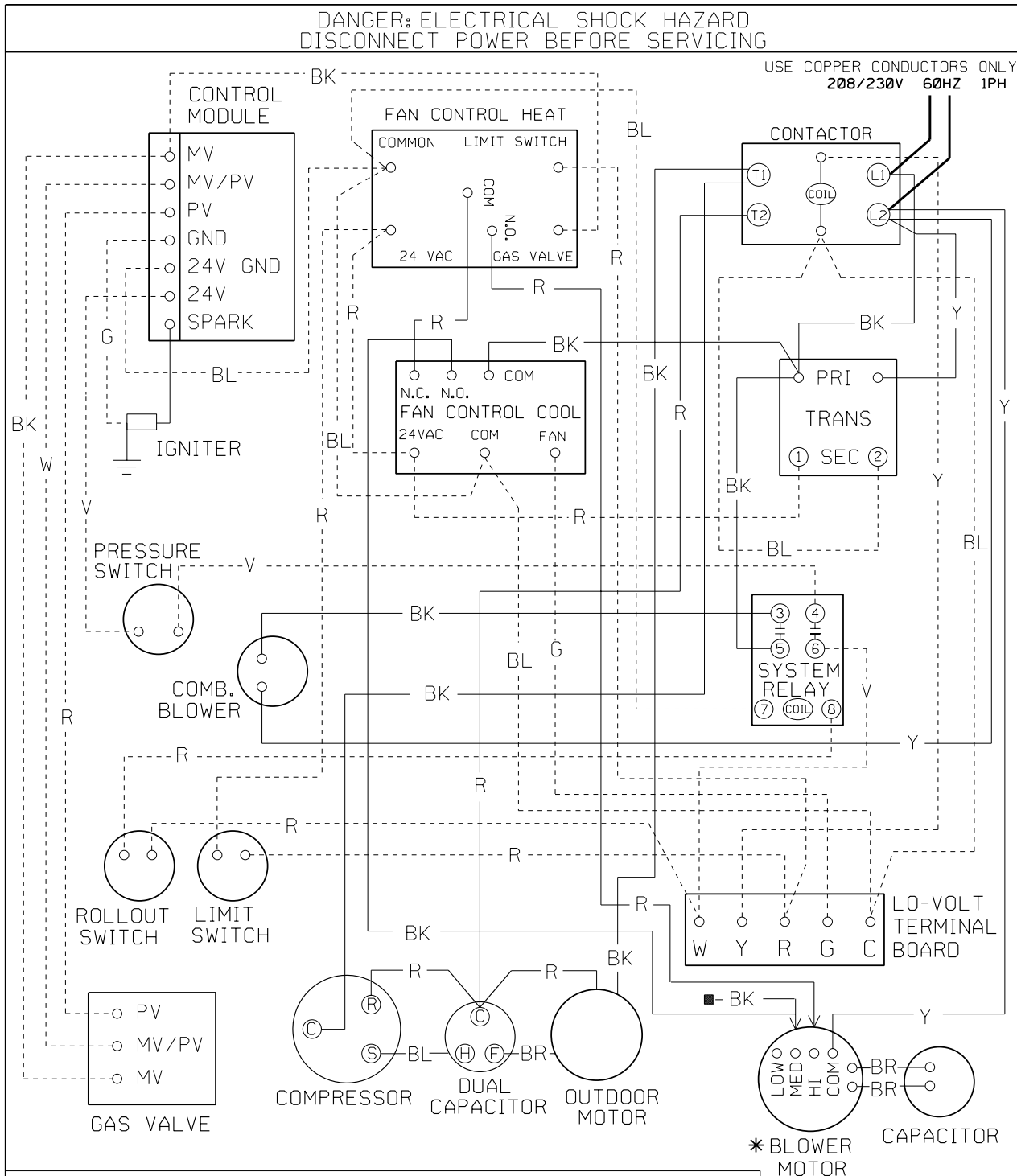

IF ANY OF THE ORIGINAL WIRE AS SUPPLIED WITH THE APPLIANCE MUST BE REPLACED, IT MUST BE REPLACED WITH TYPE AWM-105°C OR ITS EQUIVALENT.

* SEE INSTALLATION INSTRUCTIONS FOR PROPER HEATING AND COOLING CONNECTIONS FOR YOUR UNIT

—	LINE VOLTAGE FACTORY	COLOR CODE:	BLACK	BK	GREEN	G	WHITE	W
—	LINE VOLTAGE FIELD		BLUE	BL	ORANGE	O	YELLOW	Y
---	LOW VOLTAGE FACTORY		BROWN	BR	RED	R		
---	LOW VOLTAGE FIELD		GRAY	GY	VIOLET	V		

1065326

Wiring Diagram # 9. (Part # 1065327)

CONNECTION WIRING DIAGRAM

DANGER: ELECTRICAL SHOCK HAZARD
DISCONNECT POWER BEFORE SERVICING

USE COPPER CONDUCTORS ONLY
208/230V 60HZ 1PH

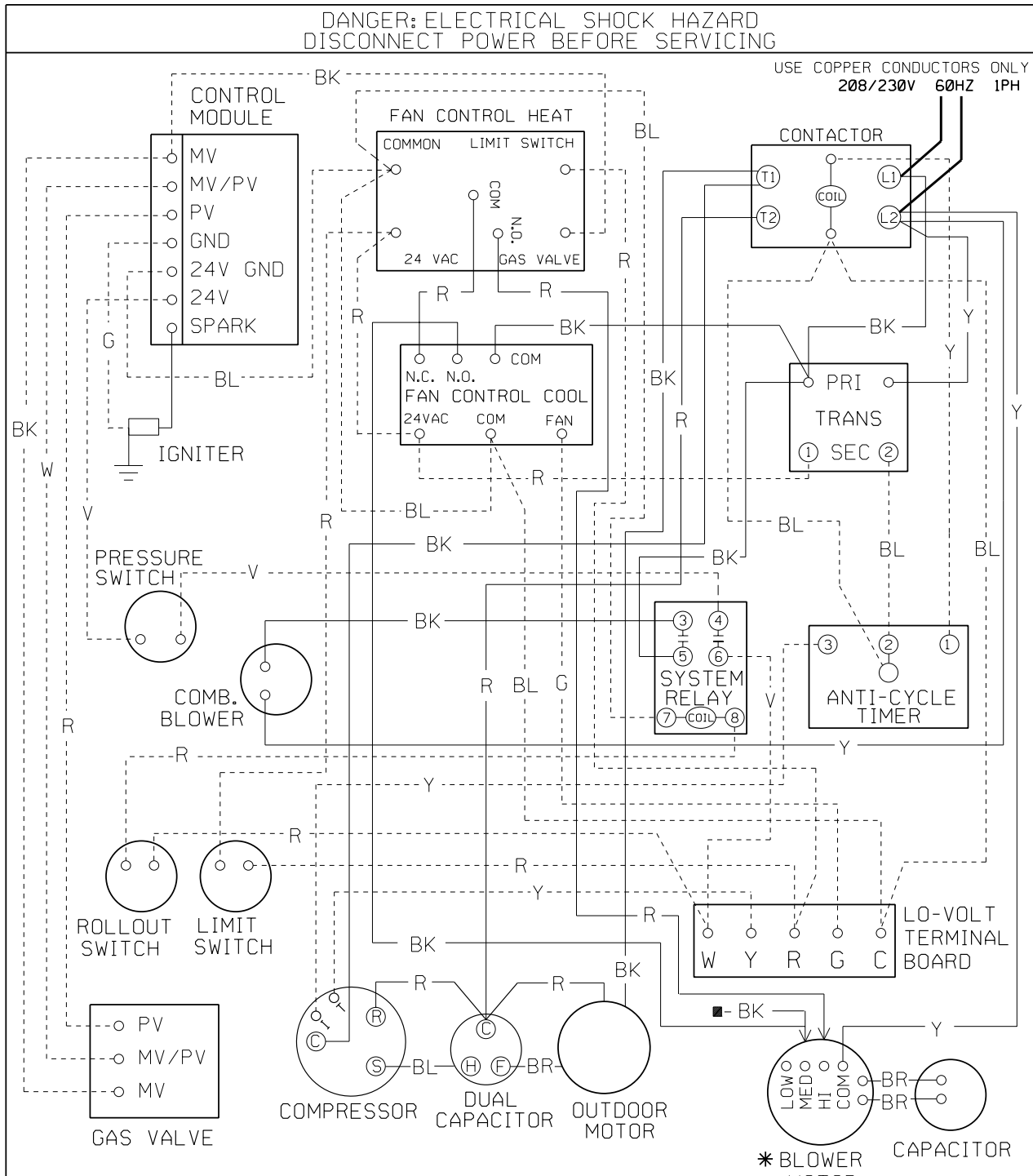

IF ANY OF THE ORIGINAL WIRE AS SUPPLIED WITH THE APPLIANCE MUST BE REPLACED, IT MUST BE REPLACED WITH TYPE AWM-105°C OR ITS EQUIVALENT.

* SEE INSTALLATION INSTRUCTIONS FOR PROPER HEATING AND COOLING CONNECTIONS FOR YOUR UNIT

— LINE VOLTAGE FACTORY	COLOR CODE:	BLACK BK	GREEN G	WHITE W
— LINE VOLTAGE FIELD		BLUE BL	ORANGE O	YELLOW Y
- - - LOW VOLTAGE FACTORY		BROWN BR	RED R	
- - - LOW VOLTAGE FIELD		GRAY GY	VIOLET V	

1065327

Wiring Diagram # 10. (Part # 1065407)

LADDER WIRING DIAGRAM

DANGER: ELECTRICAL SHOCK HAZARD
DISCONNECT POWER BEFORE SERVICING

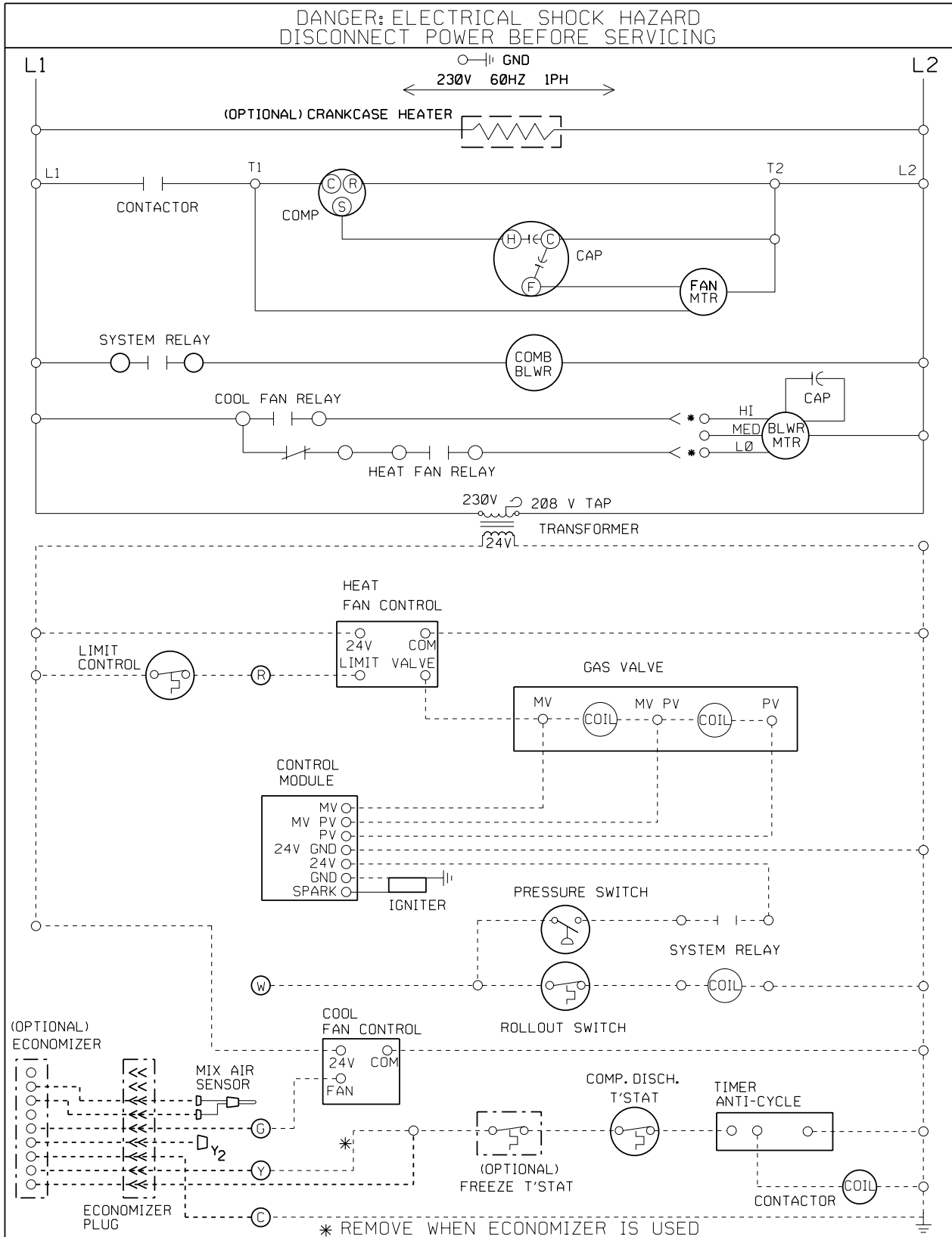

1065407-A

Wiring Diagram # 11. (Part # 1065407-A)

LADDER WIRING DIAGRAM

DANGER: ELECTRICAL SHOCK HAZARD
DISCONNECT POWER BEFORE SERVICING

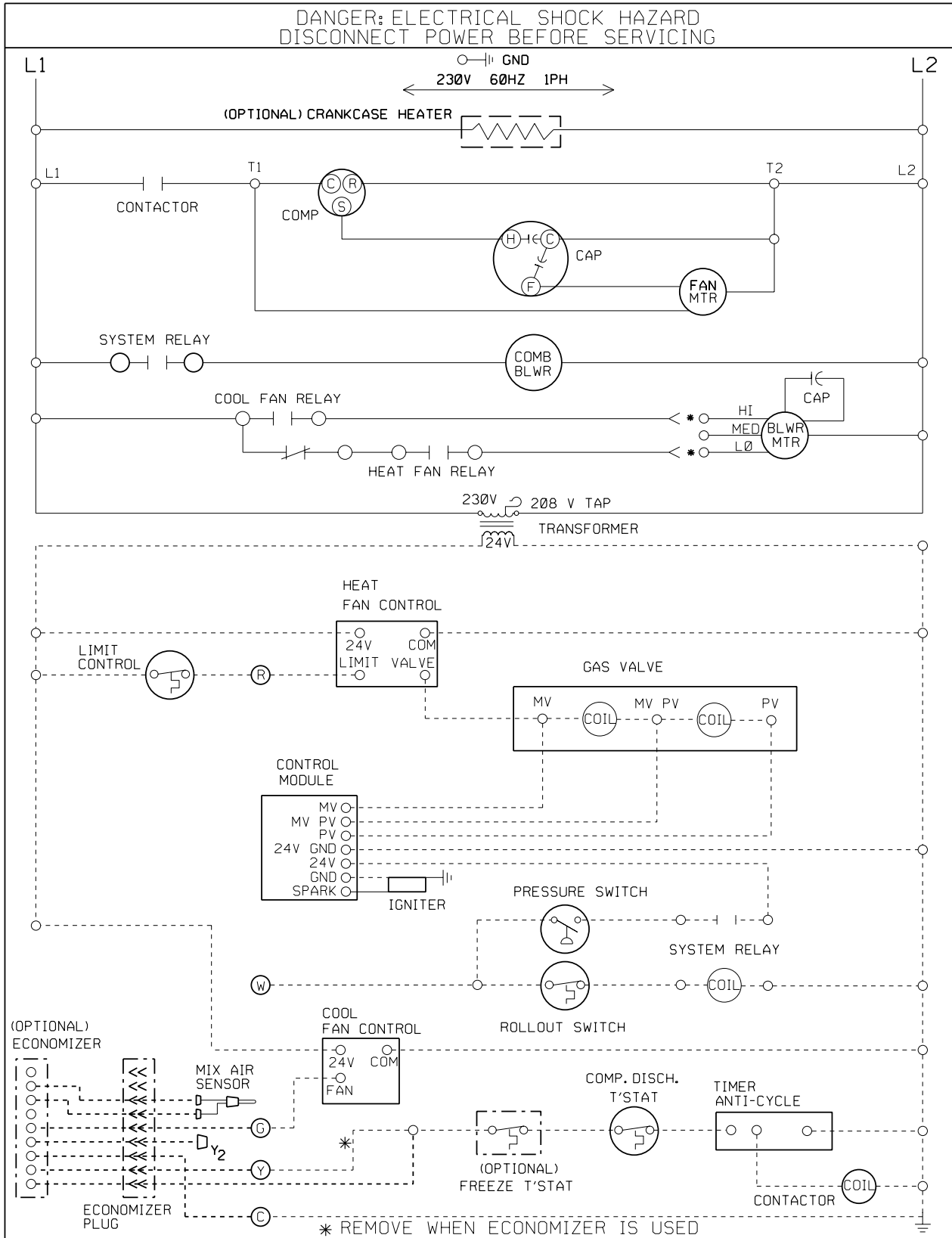

1065407-A

Wiring Diagram # 12. (Part # 1065521-A)

CONNECTION WIRING DIAGRAM

DANGER: ELECTRICAL SHOCK HAZARD
DISCONNECT POWER BEFORE SERVICING

USE COPPER CONDUCTORS ONLY
208/230V 60HZ 1PH

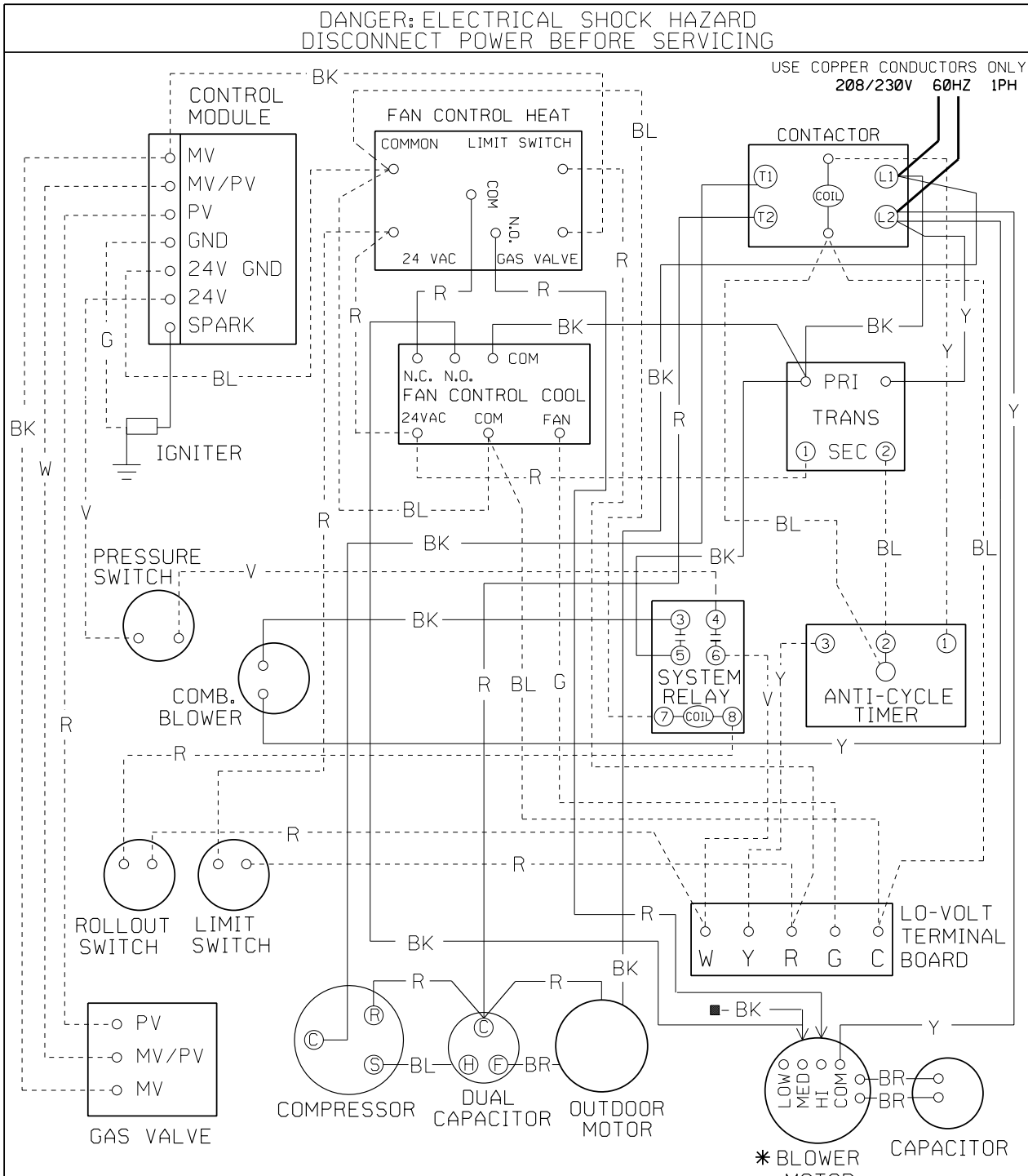

IF ANY OF THE ORIGINAL WIRE AS SUPPLIED WITH THE APPLIANCE MUST BE REPLACED, IT MUST BE REPLACED WITH TYPE AWM-105°C OR ITS EQUIVALENT.

* SEE INSTALLATION INSTRUCTIONS FOR PROPER HEATING AND COOLING CONNECTIONS FOR YOUR UNIT

— LINE VOLTAGE FACTORY	COLOR CODE:	BLACK BK	GREEN G	WHITE W
— LINE VOLTAGE FIELD		BLUE BL	ORANGE O	YELLOW Y
- - - LOW VOLTAGE FACTORY		BROWN BR	RED R	
- - - LOW VOLTAGE FIELD		GRAY GY	VIOLET V	

1065521-A

Wiring Diagram # 13. (Part # 106525-B)

LADDER WIRING DIAGRAM

DANGER: ELECTRICAL SHOCK HAZARD
DISCONNECT POWER BEFORE SERVICING

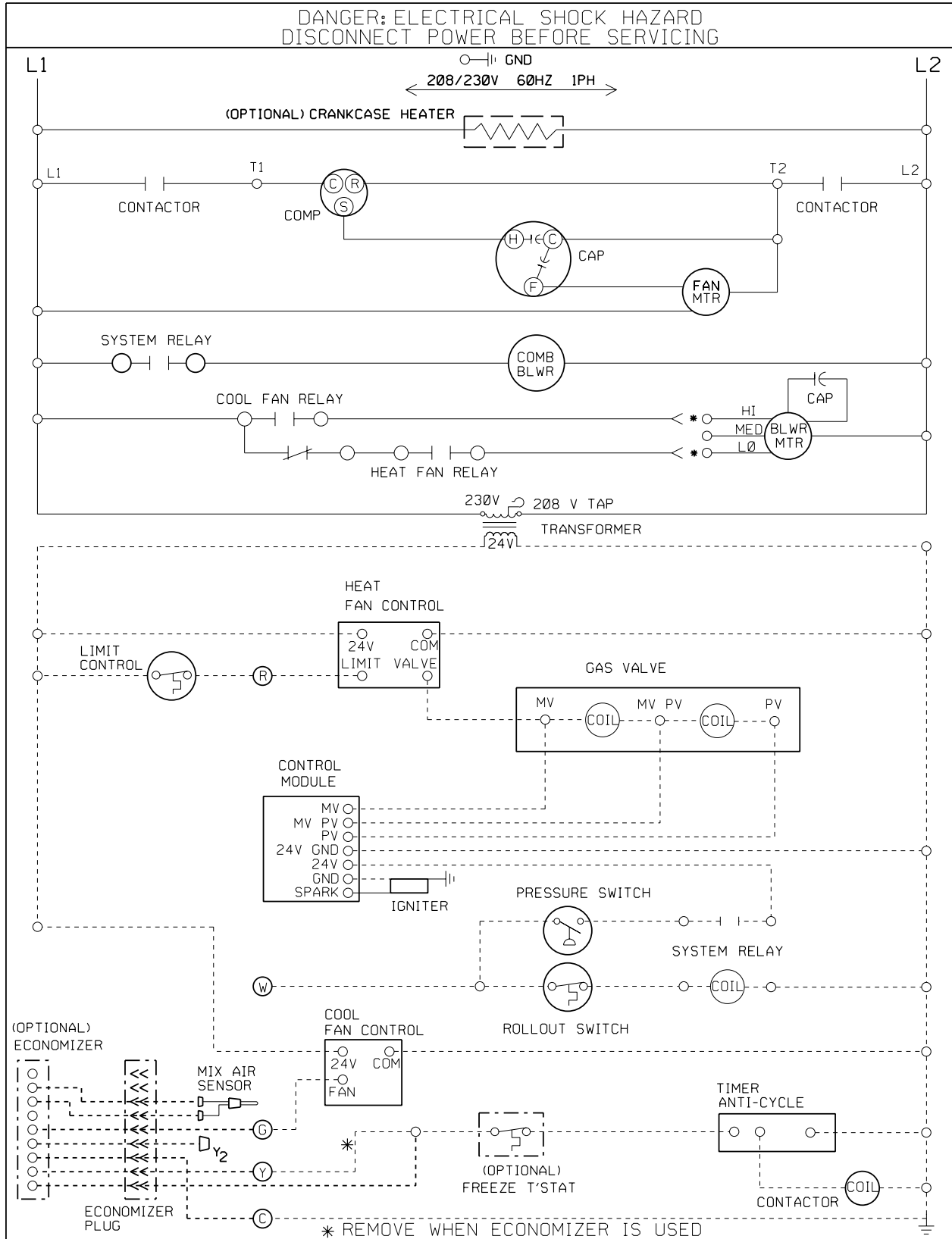

106525-B

Wiring Diagram # 14. (Part # 1066307)

CONNECTION WIRING DIAGRAM

DANGER: ELECTRICAL SHOCK HAZARD
DISCONNECT POWER BEFORE SERVICING

USE COPPER CONDUCTORS ONLY
208/230V 60HZ 1PH

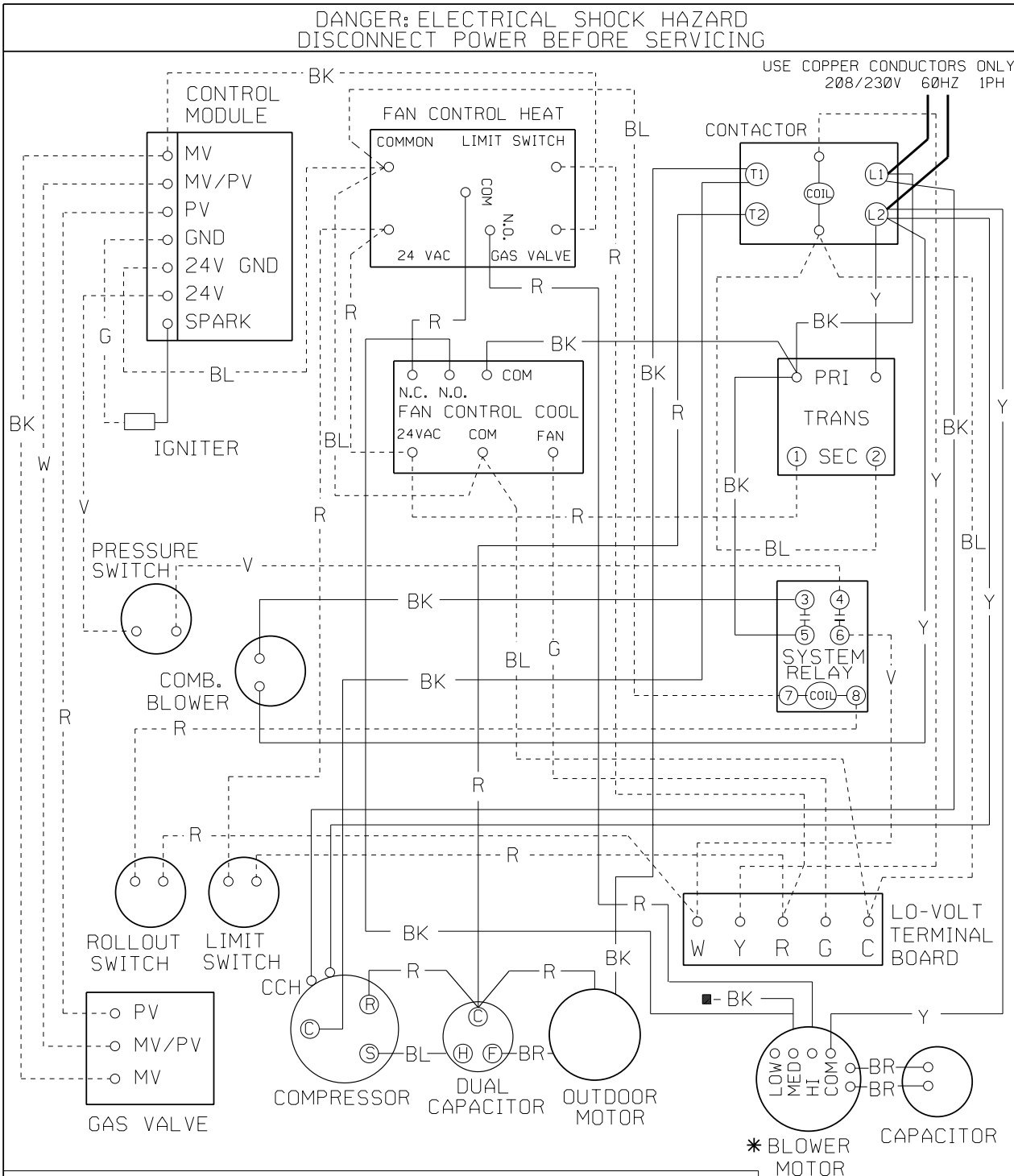

IF ANY OF THE ORIGINAL WIRE AS SUPPLIED WITH THE APPLIANCE MUST BE REPLACED, IT MUST BE REPLACED WITH TYPE AWM-105°C OR ITS EQUIVALENT.

* SEE INSTALLATION INSTRUCTIONS FOR PROPER HEATING AND COOLING CONNECTIONS FOR YOUR UNIT

—	LINE VOLTAGE FACTORY	COLOR CODE:	BLACK	BK	GREEN	G	WHITE	W
—	LINE VOLTAGE FIELD		BLUE	BL	ORANGE	O	YELLOW	Y
- - -	LOW VOLTAGE FACTORY		BROWN	BR	RED	R		
- - -	LOW VOLTAGE FIELD		GRAY	GY	VIOLET	V		

1066307

Wiring Diagram # 15. (Part # 1067574)

LADDER WIRING DIAGRAM

DANGER: ELECTRICAL SHOCK HAZARD
DISCONNECT POWER BEFORE SERVICING

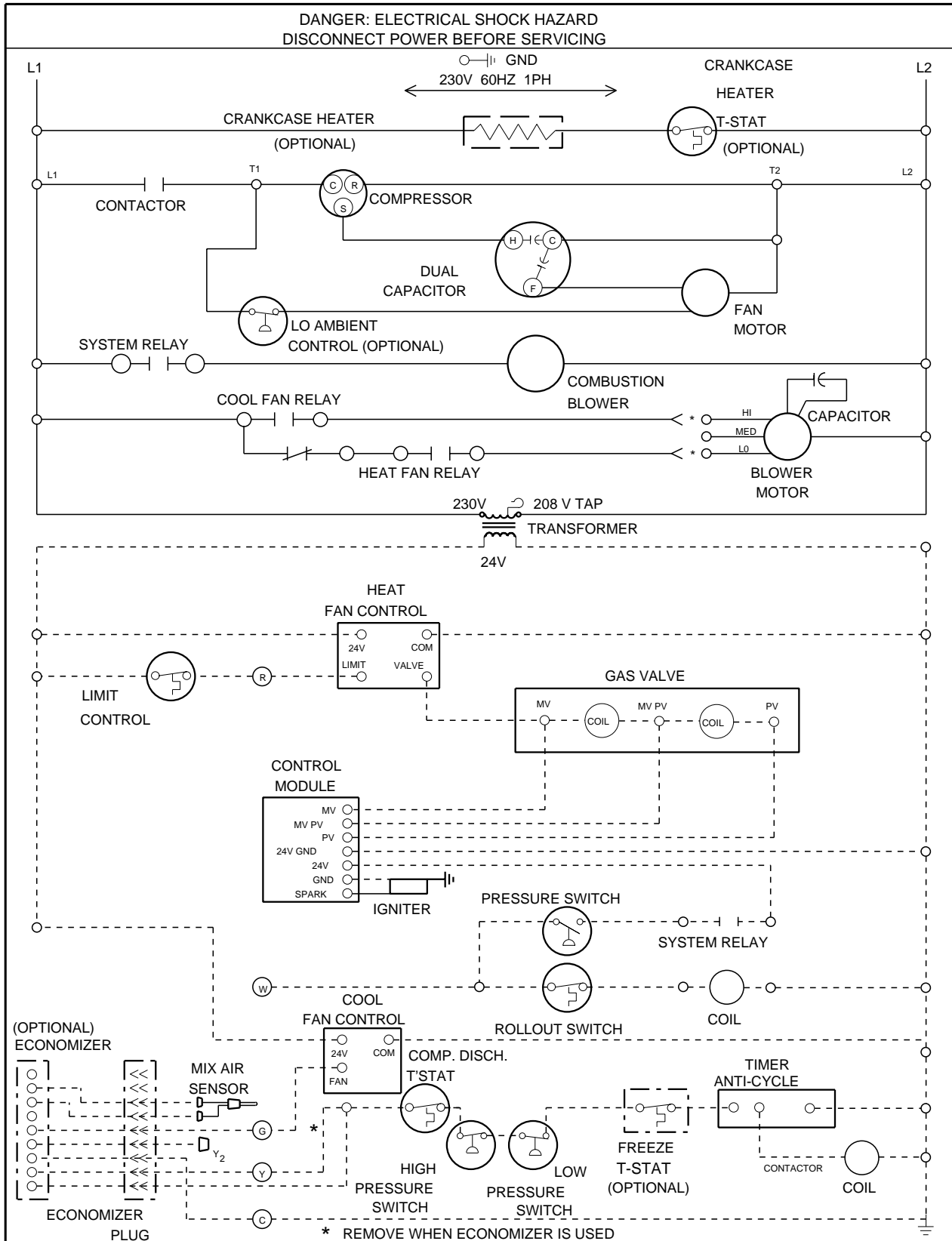

1067574

Wiring Diagram # 16. (Part # 1067575)

CONNECTION WIRING DIAGRAM

**DANGER: ELECTRICAL SHOCK HAZARD
DISCONNECT POWER BEFORE SERVICING**

USE COPPER CONDUCTORS ONLY
208/230V 60HZ 1PH

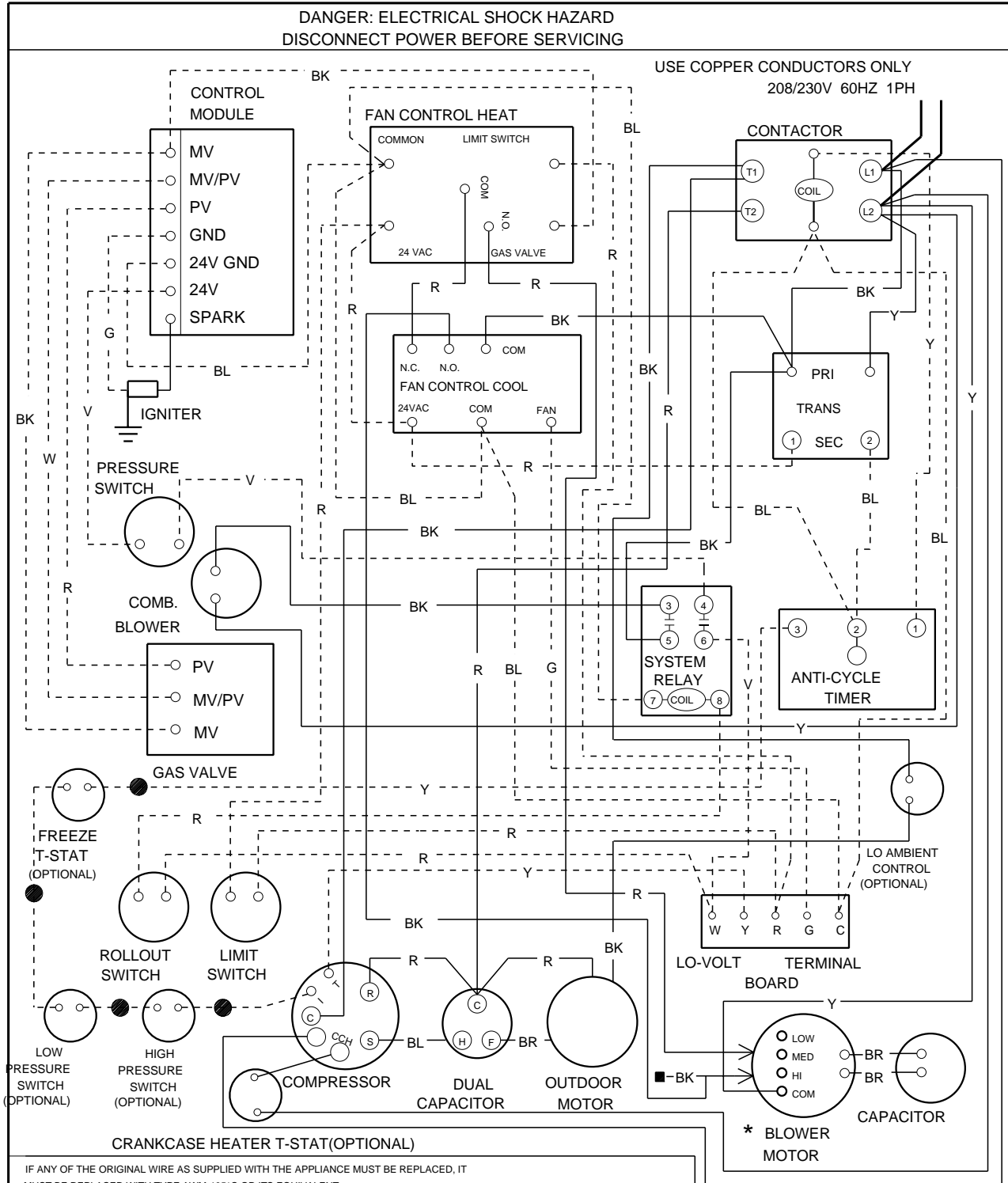

IF ANY OF THE ORIGINAL WIRE AS SUPPLIED WITH THE APPLIANCE MUST BE REPLACED, IT MUST BE REPLACED WITH TYPE AWM-105°C OR ITS EQUIVALENT.

* SEE INSTALLATION INSTRUCTIONS FOR PROPER HEATING AND COOLING CONNECTIONS FOR YOUR UNIT

<p>— LINE VOLTAGE FACTORY</p> <p>— LINE VOLTAGE FIELD</p> <p>— LOW VOLTAGE FACTORY</p> <p>— LOW VOLTAGE FIELD</p>	<p>COLOR CODE:</p> <p>BLACK BK</p> <p>BLUE BL</p> <p>BROWN BR</p> <p>GRAY GY</p> <p>GREEN G</p> <p>ORANGE O</p> <p>RED R</p> <p>VIOLET V</p> <p>WHITE W</p> <p>YELLOW Y</p>	<p>1067575</p>
---	---	----------------

Wiring Diagram # 17. (Part # 1067663)

CONNECTION WIRING DIAGRAM

DANGER: ELECTRICAL SHOCK HAZARD
DISCONNECT POWER BEFORE SERVICING

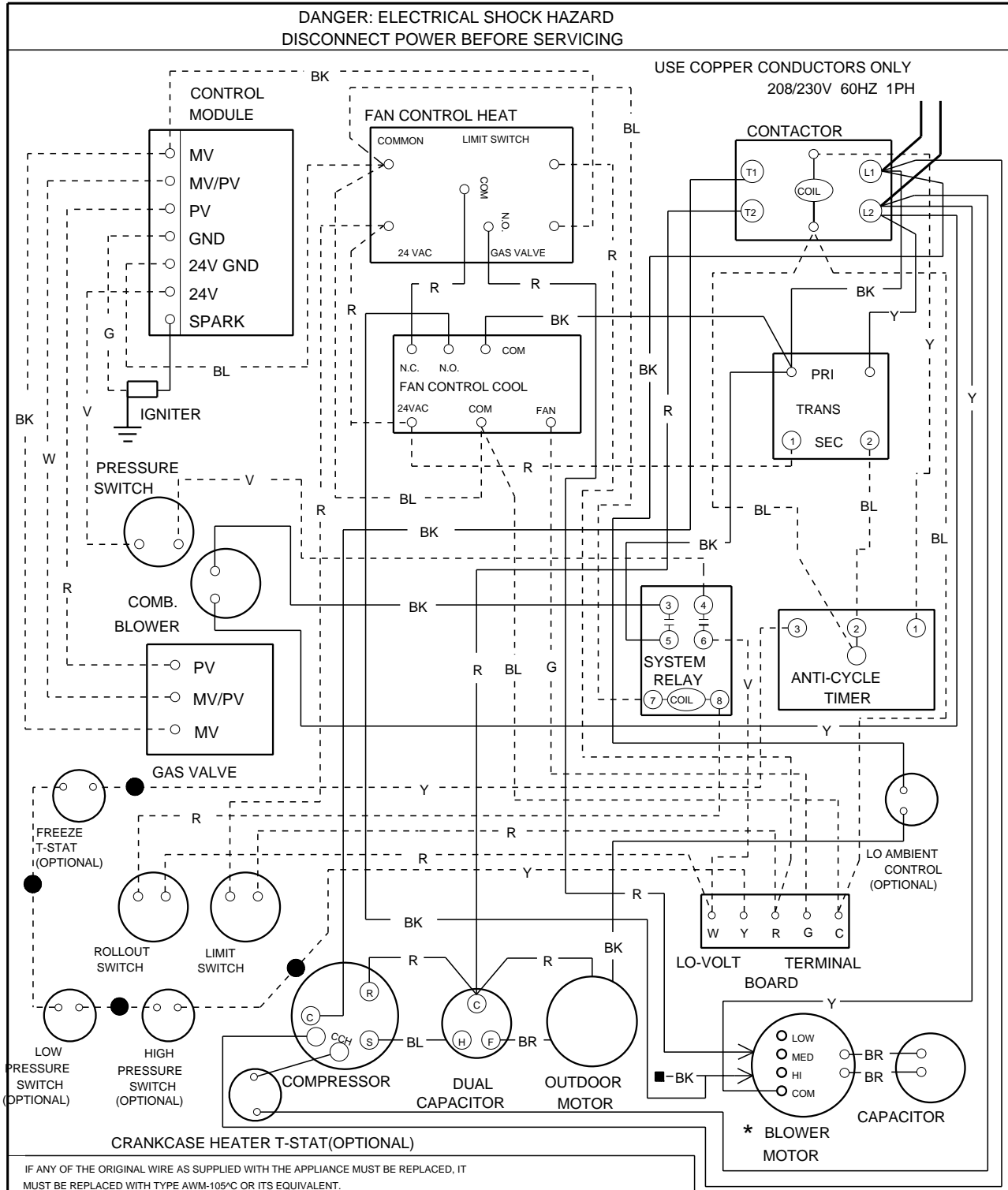

* SEE INSTALLATION INSTRUCTIONS FOR PROPER HEATING AND COOLING CONNECTIONS FOR YOUR UNIT

—	LINE VOLTAGE FACTORY	COLOR CODE:	BLACK	BK	GREEN	G	WHITE	W
—	LINE VOLTAGE FIELD		BLUE	BL	ORANGE	O	YELLOW	Y
—	LOW VOLTAGE FACTORY		BROWN	BR	RED	R		
—	LOW VOLTAGE FIELD		GRAY	GY	VIOLET	V		

1067663

Wiring Diagram # 18. (Part # 1067664)

LADDER WIRING DIAGRAM

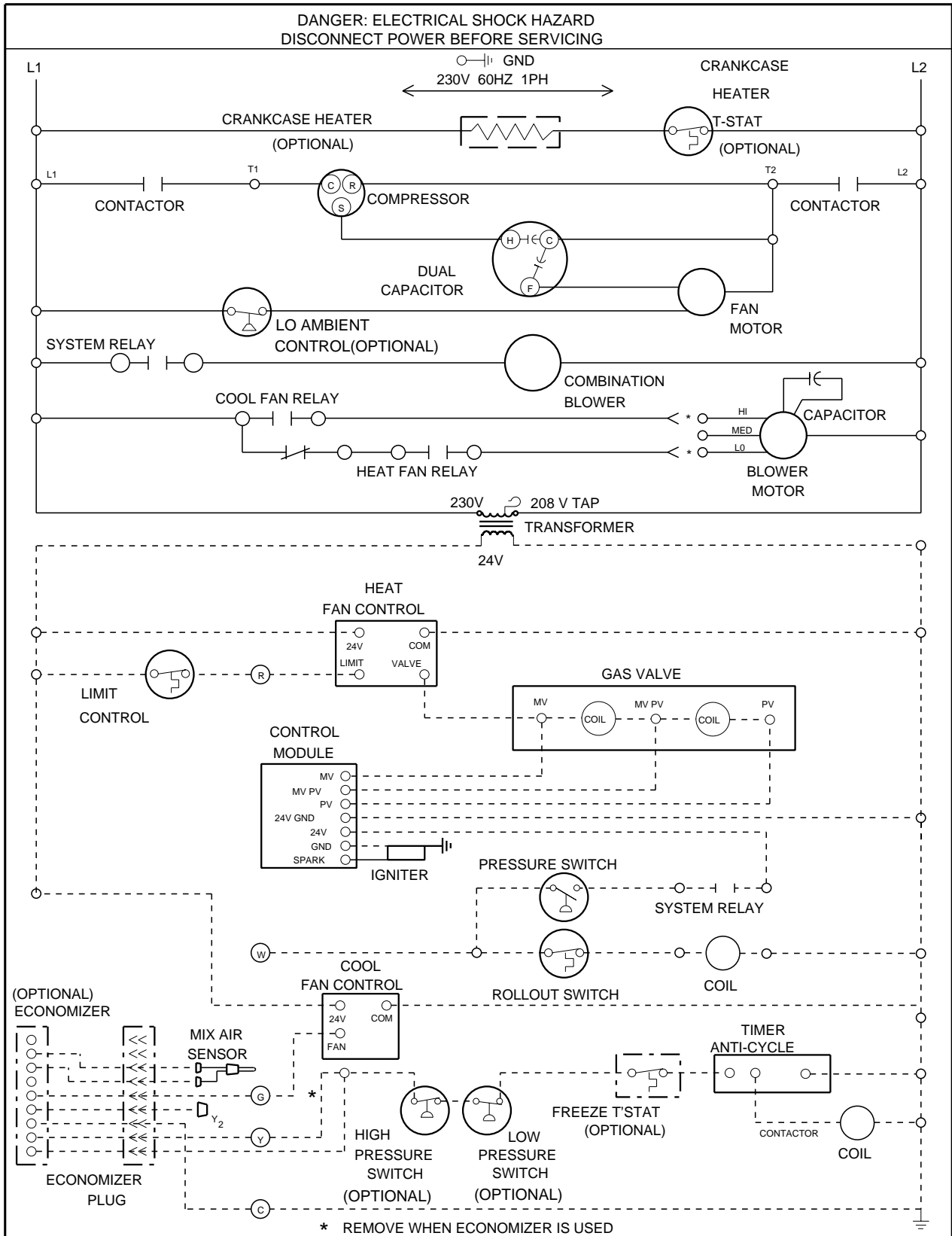

1067664

Wiring Diagram # 19. (Part # 1067778)

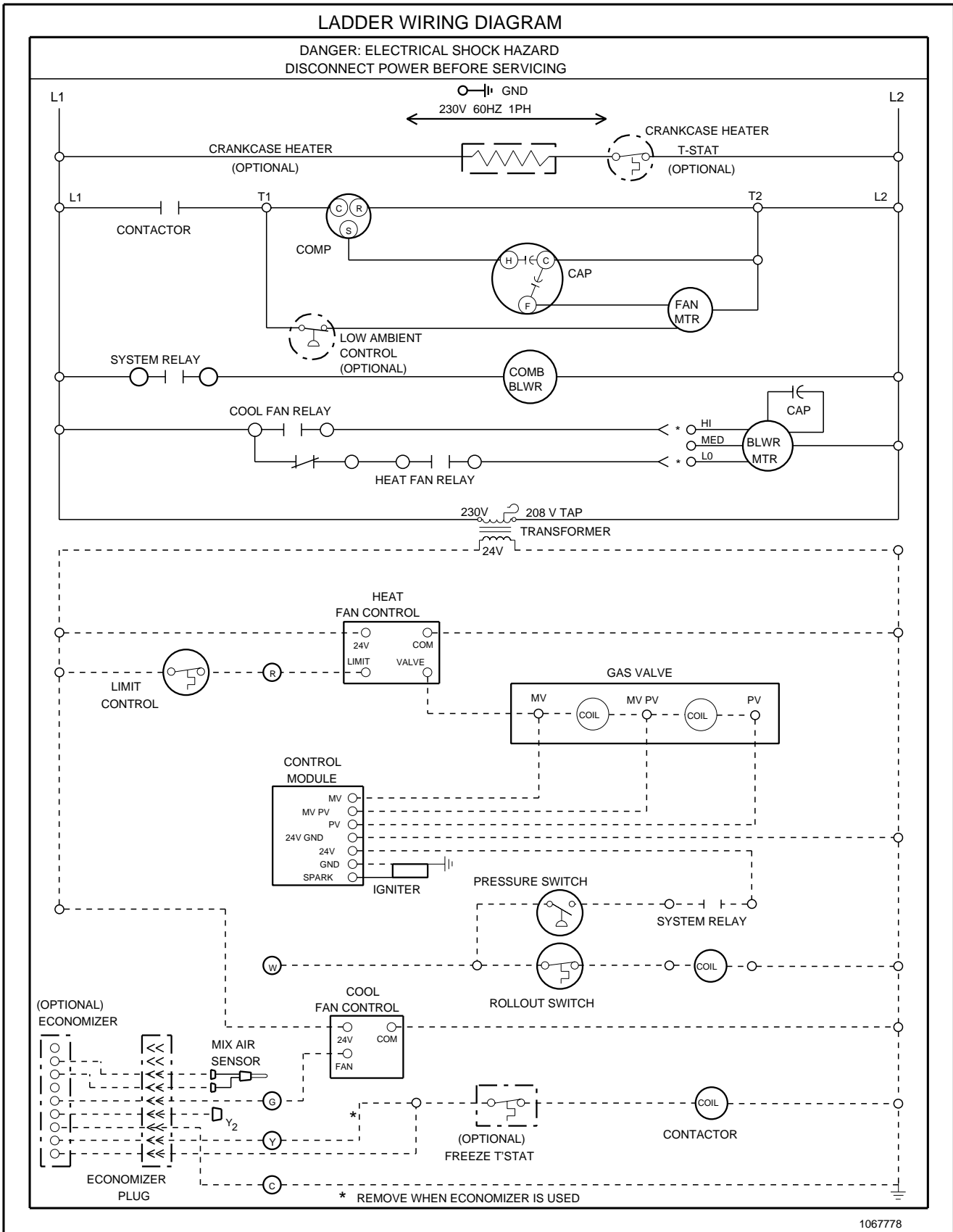

Wiring Diagram # 20. (Part # 1067779)

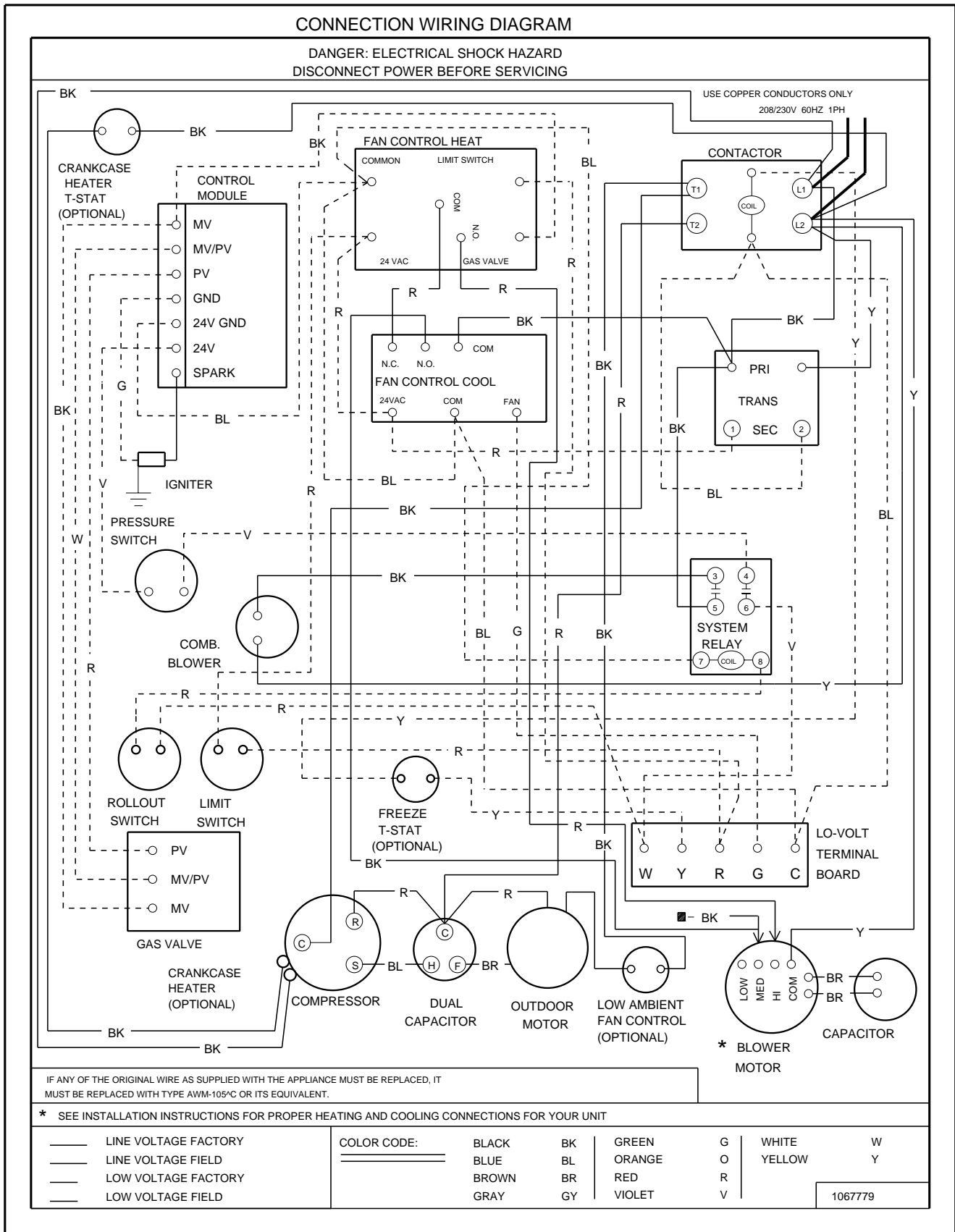

Wiring Diagram # 21. (Part # 1067785)

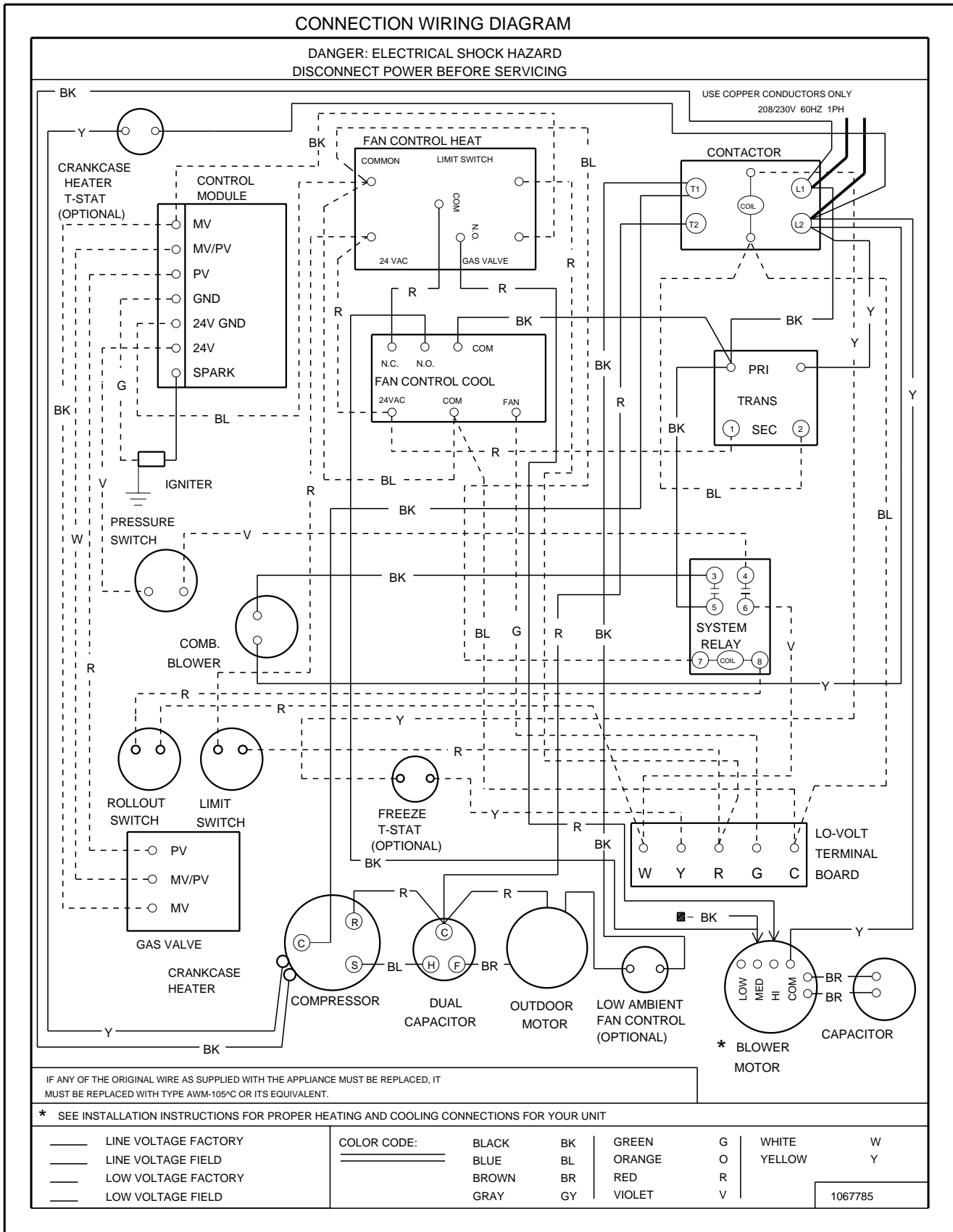

Wiring Diagram # 22. (Part # 1067817)

LADDER WIRING DIAGRAM

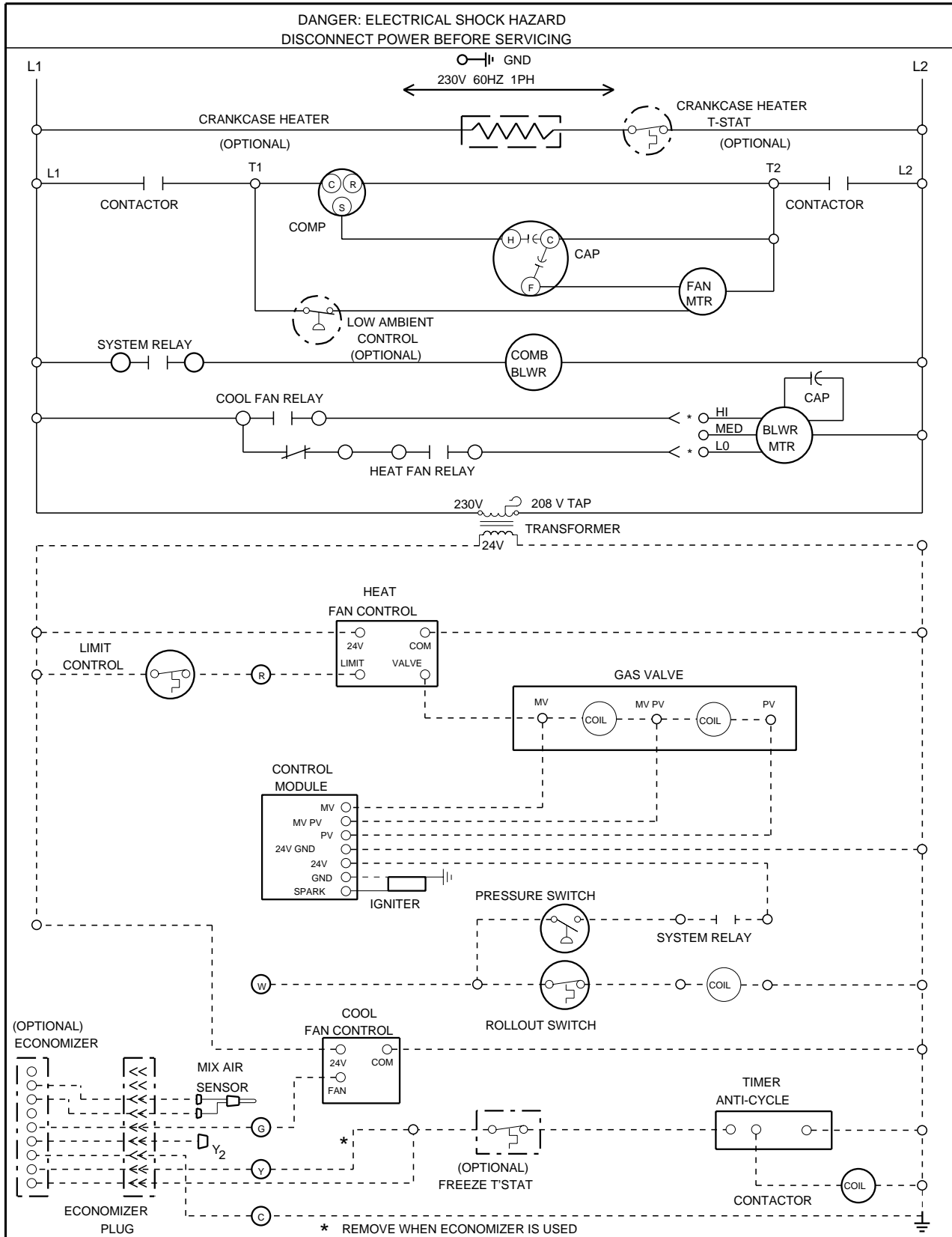

1067817

Wiring Diagram # 23. (Part # 1067818)

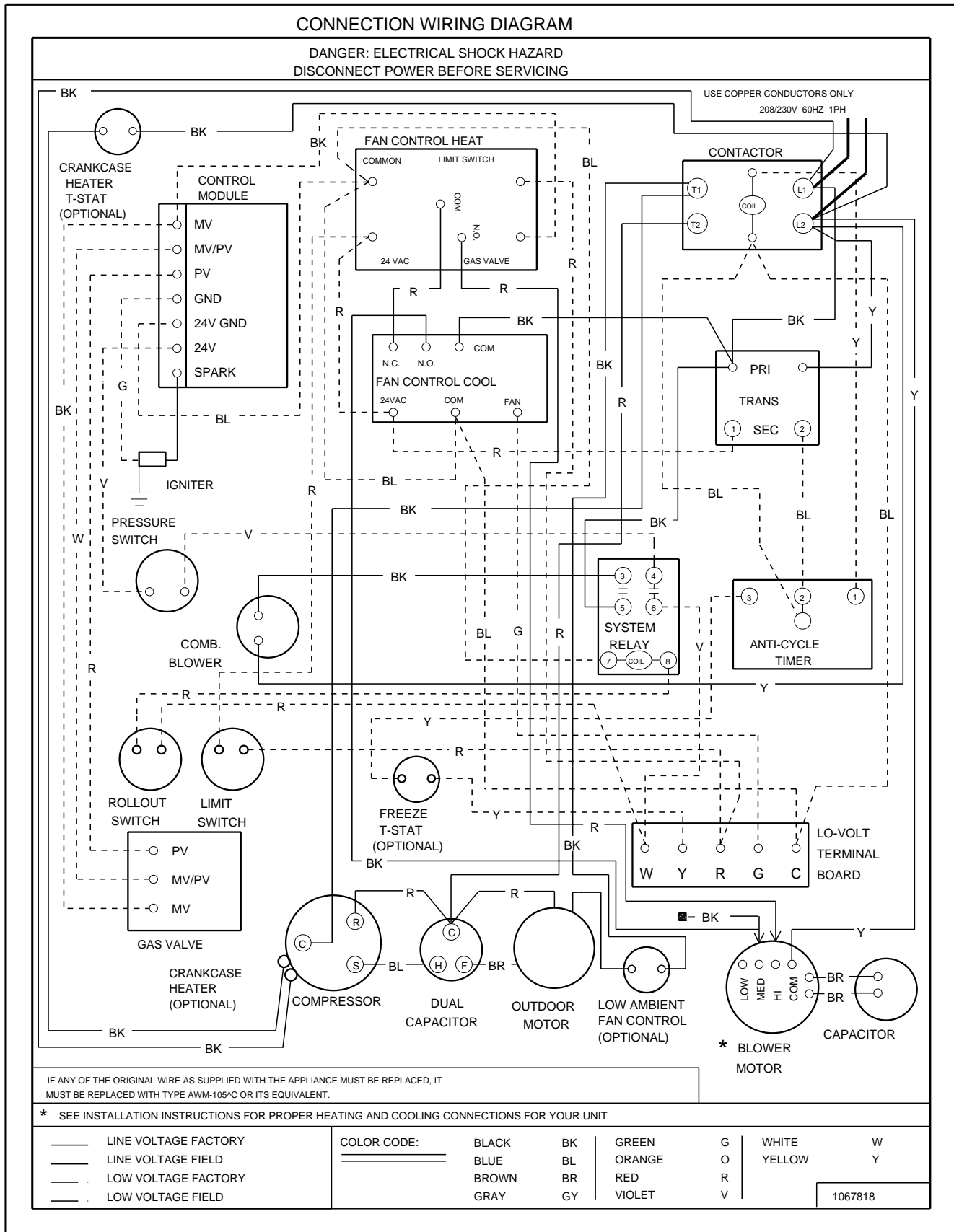

Wiring Diagram # 24. (Part # 1067903)

LADDER WIRING DIAGRAM

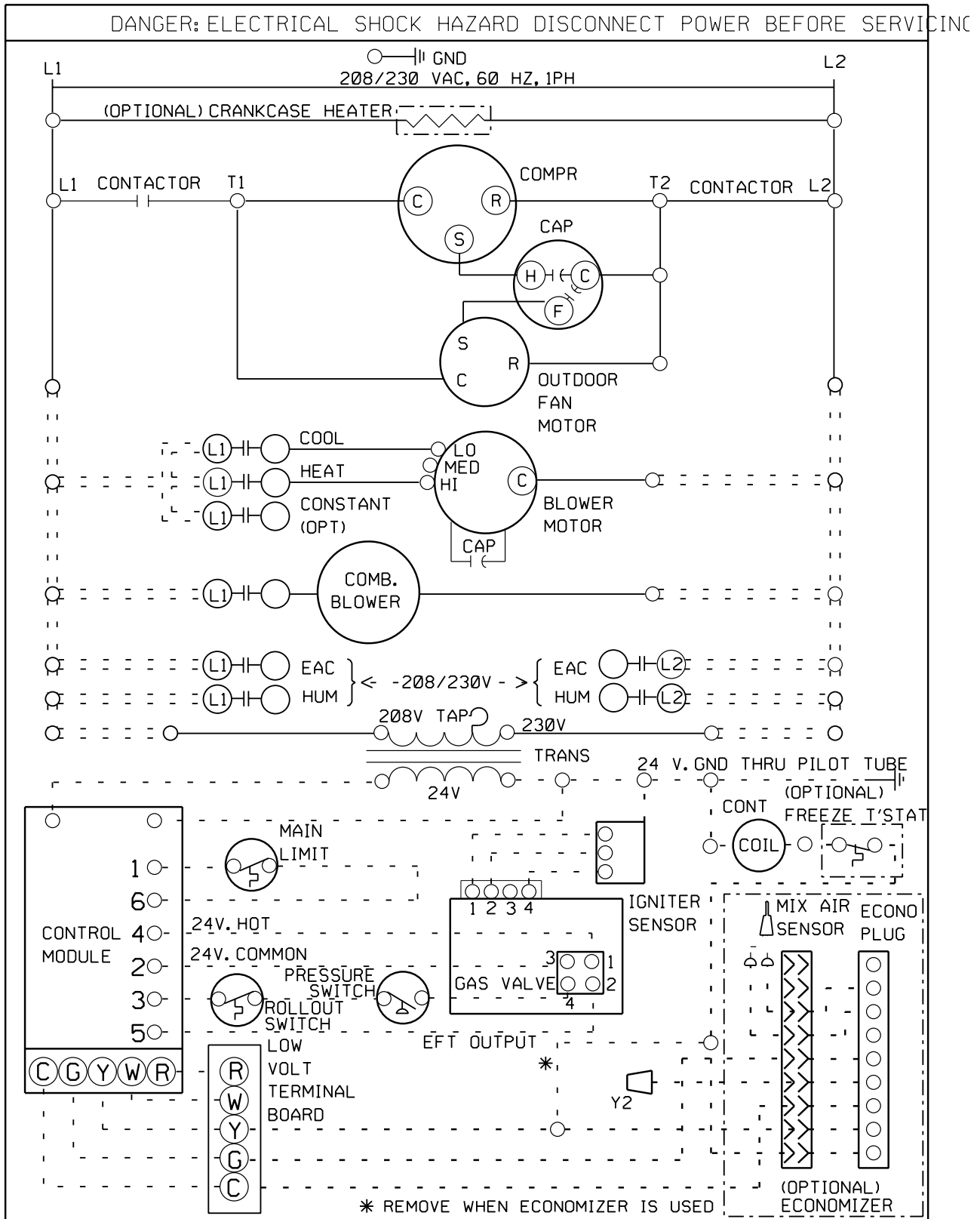

1067903

Wiring Diagram # 25. (Part # 1067904)

CONNECTION WIRING DIAGRAM

DANGER: ELECTRICAL SHOCK HAZARD DISCONNECT POWER BEFORE SERVICING

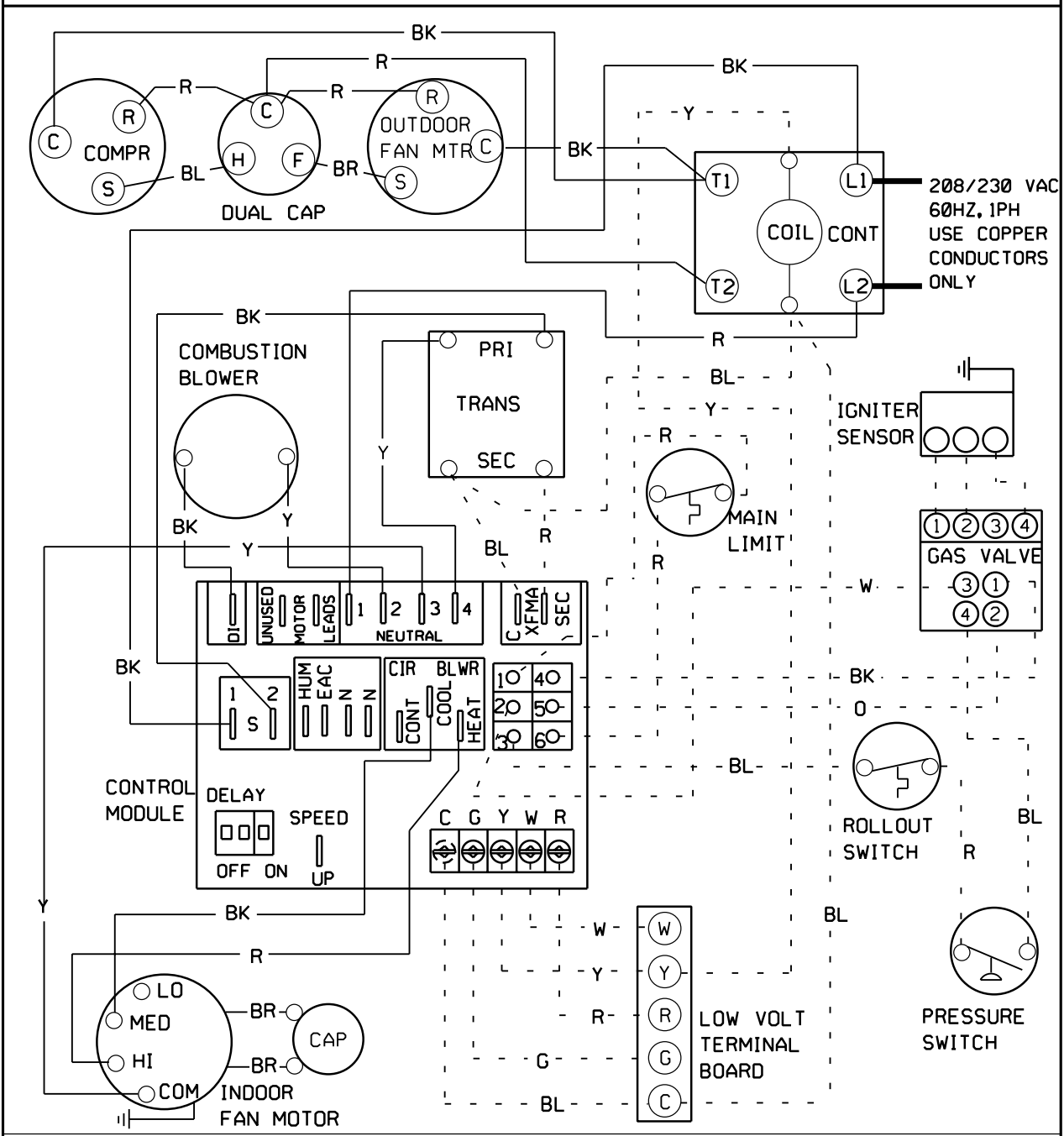

IF ANY OF THE ORIGINAL WIRE AS SUPPLIED WITH THE APPLIANCE MUST BE REPLACED, IT MUST BE REPLACED WITH TYPE AWM-105°C OR ITS EQUIVALENT.

* SEE INSTALLATION INSTRUCTIONS FOR PROPER HEATING AND COOLING CONNECTIONS FOR YOUR UNIT

—	LINE VOLTAGE FACTORY	COLOR CODE:	BLACK	BK	GREEN	G	WHITE	W
—	LINE VOLTAGE FIELD		BLUE	BL	ORANGE	O	YELLOW	Y
- - -	LOW VOLTAGE FACTORY		BROWN	BR	RED	R		
- - -	LOW VOLTAGE FIELD		GRAY	GY	VIOLET	V		
≡	INTERNAL CIR BRD WIRING							

Wiring Diagram # 26. (Part # 1067916)

CONNECTION WIRING DIAGRAM

DANGER: ELECTRICAL SHOCK HAZARD DISCONNECT POWER BEFORE SERVICING

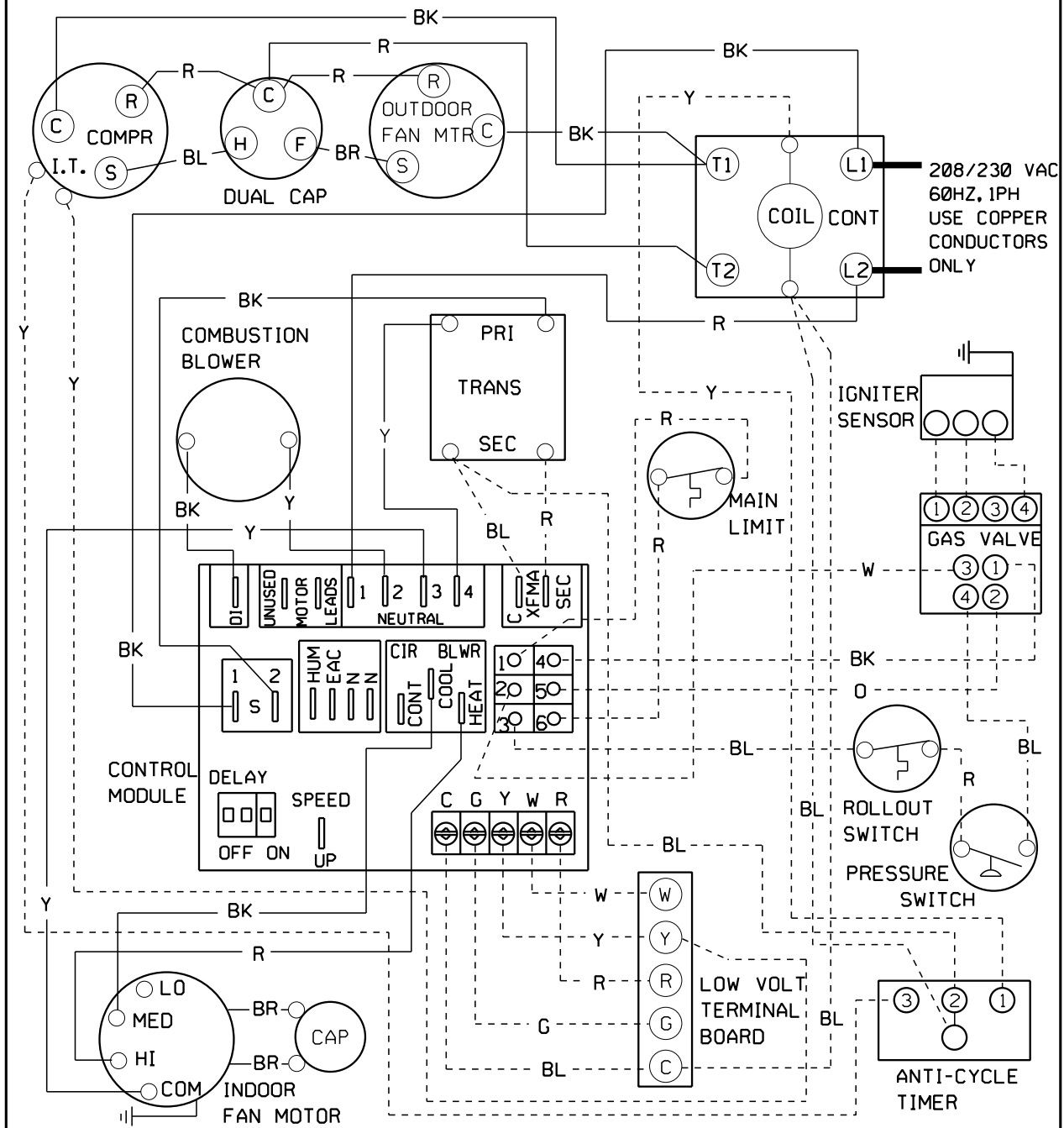

IF ANY OF THE ORIGINAL WIRE AS SUPPLIED WITH THE APPLIANCE MUST BE REPLACED, IT MUST BE REPLACED WITH TYPE AWM-105°C OR ITS EQUIVALENT.

* SEE INSTALLATION INSTRUCTIONS FOR PROPER HEATING AND COOLING CONNECTIONS FOR YOUR UNIT

— LINE VOLTAGE FACTORY - - - LOW VOLTAGE FACTORY = = = INTERNAL CIRCUIT
 — LINE VOLTAGE FIELD - - - LOW VOLTAGE FIELD BOARD WIRING

COLOR CODE:	GREEN ORANGE	G O	BLACK BLUE	BK BL	BROWN GRAY	BR GY	RED VIOLET	R V	WHITE YELLOW	W Y
-------------	-----------------	--------	---------------	----------	---------------	----------	---------------	--------	-----------------	--------

Wiring Diagram # 27. (Part # 1067917)

LADDER WIRING DIAGRAM

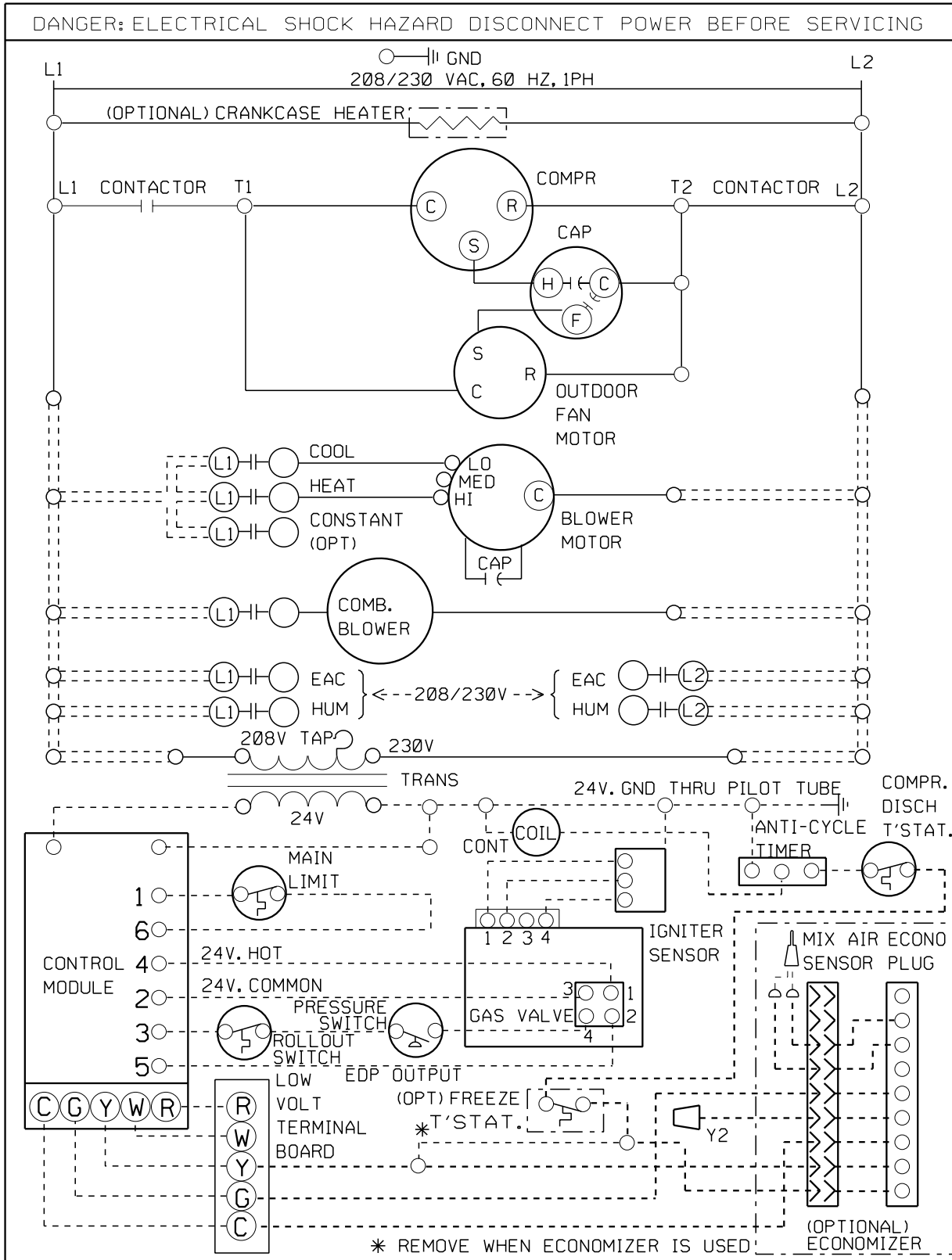

1067917

Wiring Diagram # 28. (Part # 1067925)

CONNECTION WIRING DIAGRAM

DANGER: ELECTRICAL SHOCK HAZARD DISCONNECT POWER BEFORE SERVICING

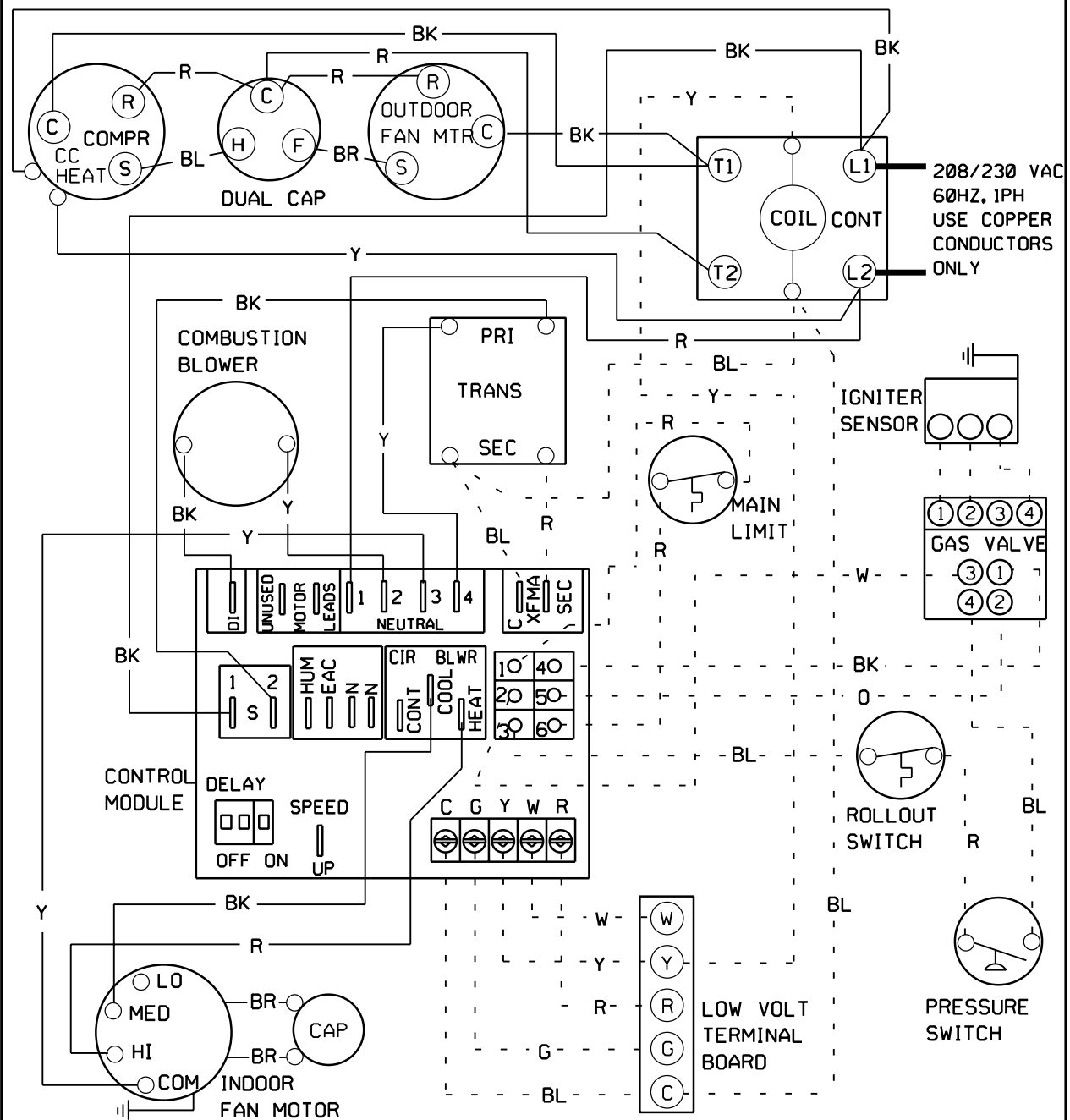

IF ANY OF THE ORIGINAL WIRE AS SUPPLIED WITH THE APPLIANCE MUST BE REPLACED, IT MUST BE REPLACED WITH TYPE AWM-105°C OR ITS EQUIVALENT.

* SEE INSTALLATION INSTRUCTIONS FOR PROPER HEATING AND COOLING CONNECTIONS FOR YOUR UNIT

—	LINE VOLTAGE FACTORY	COLOR CODE:	BLACK	BK	GREEN	G	WHITE	W
—	LINE VOLTAGE FIELD		BLUE	BL	ORANGE	O	YELLOW	Y
- - -	LOW VOLTAGE FACTORY		BROWN	BR	RED	R		
- - -	LOW VOLTAGE FIELD		GRAY	GY	VIOLET	V		
—	INTERNAL CIR BRD WIRING							

Wiring Diagram # 29. (Part # 1067961)

CONNECTION WIRING DIAGRAM

DANGER: ELECTRICAL SHOCK HAZARD DISCONNECT POWER BEFORE SERVICING

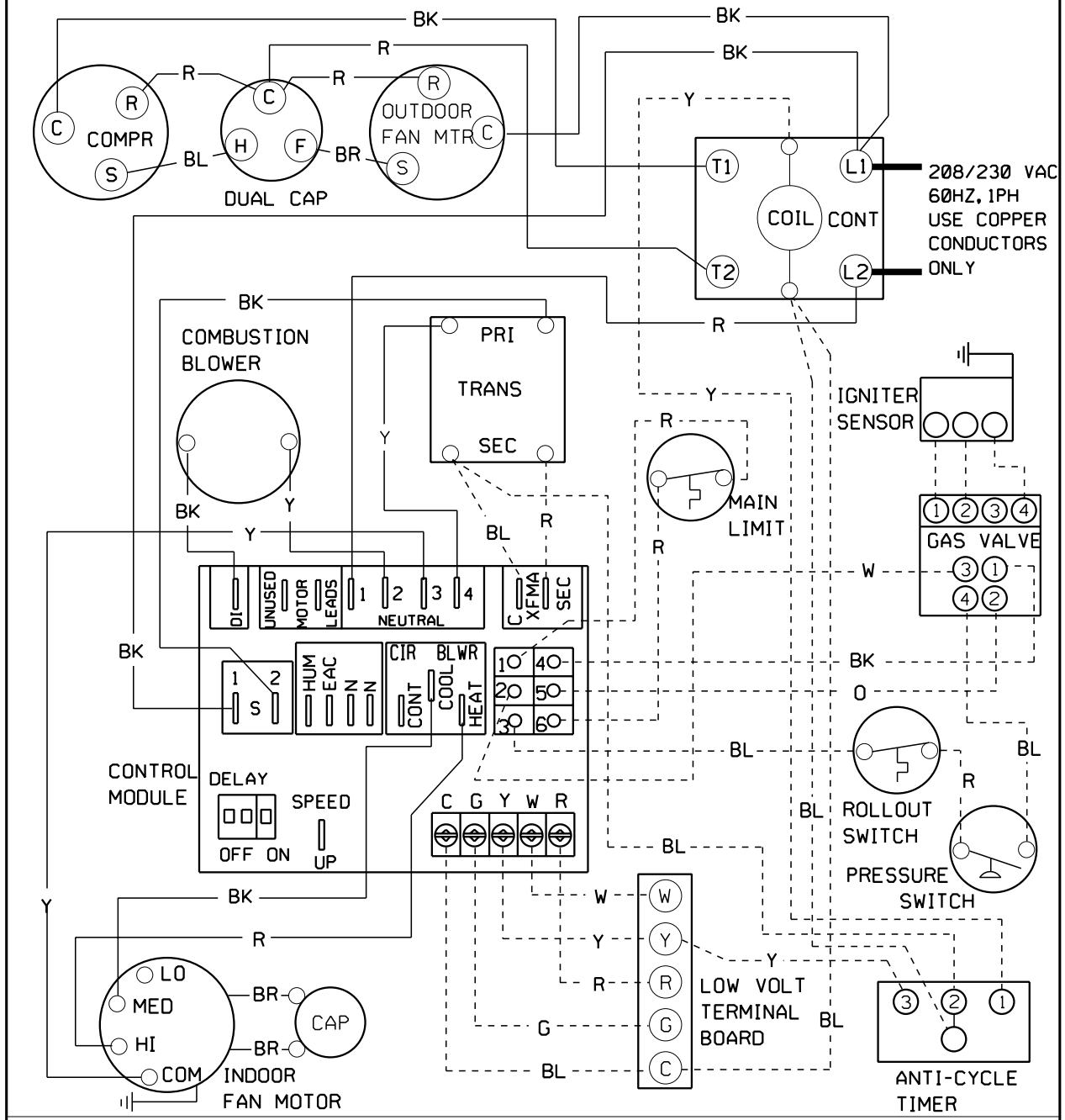

IF ANY OF THE ORIGINAL WIRE AS SUPPLIED WITH THE APPLIANCE MUST BE REPLACED, IT MUST BE REPLACED WITH TYPE AWM-105°C OR ITS EQUIVALENT.

* SEE INSTALLATION INSTRUCTIONS FOR PROPER HEATING AND COOLING CONNECTIONS FOR YOUR UNIT

—	LINE VOLTAGE FACTORY	COLOR CODE:	BLACK	BK	GREEN	G	WHITE	W
—	LINE VOLTAGE FIELD		BLUE	BL	ORANGE	O	YELLOW	Y
- - -	LOW VOLTAGE FACTORY		BROWN	BR	RED	R		
- - -	LOW VOLTAGE FIELD		GRAY	GY	VIOLET	V		
—	INTERNAL CIR BRD WIRING							

Wiring Diagram # 30. (Part # 1067962)

LADDER WIRING DIAGRAM

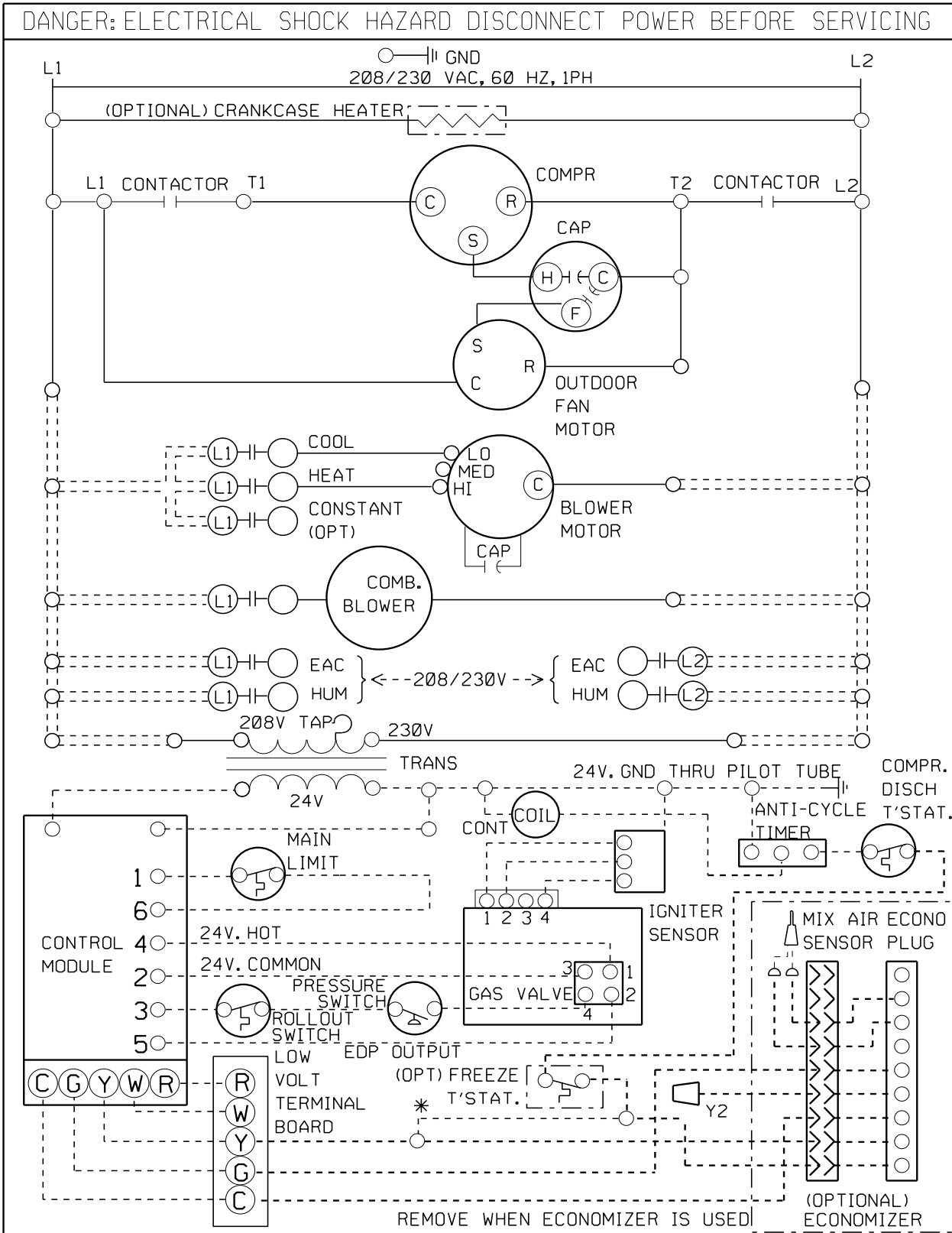

1067962

Wiring Diagram # 31. (Part # 1068002)

LADDER WIRING DIAGRAM

DANGER: ELECTRICAL SHOCK HAZARD DISCONNECT POWER BEFORE SERVICING

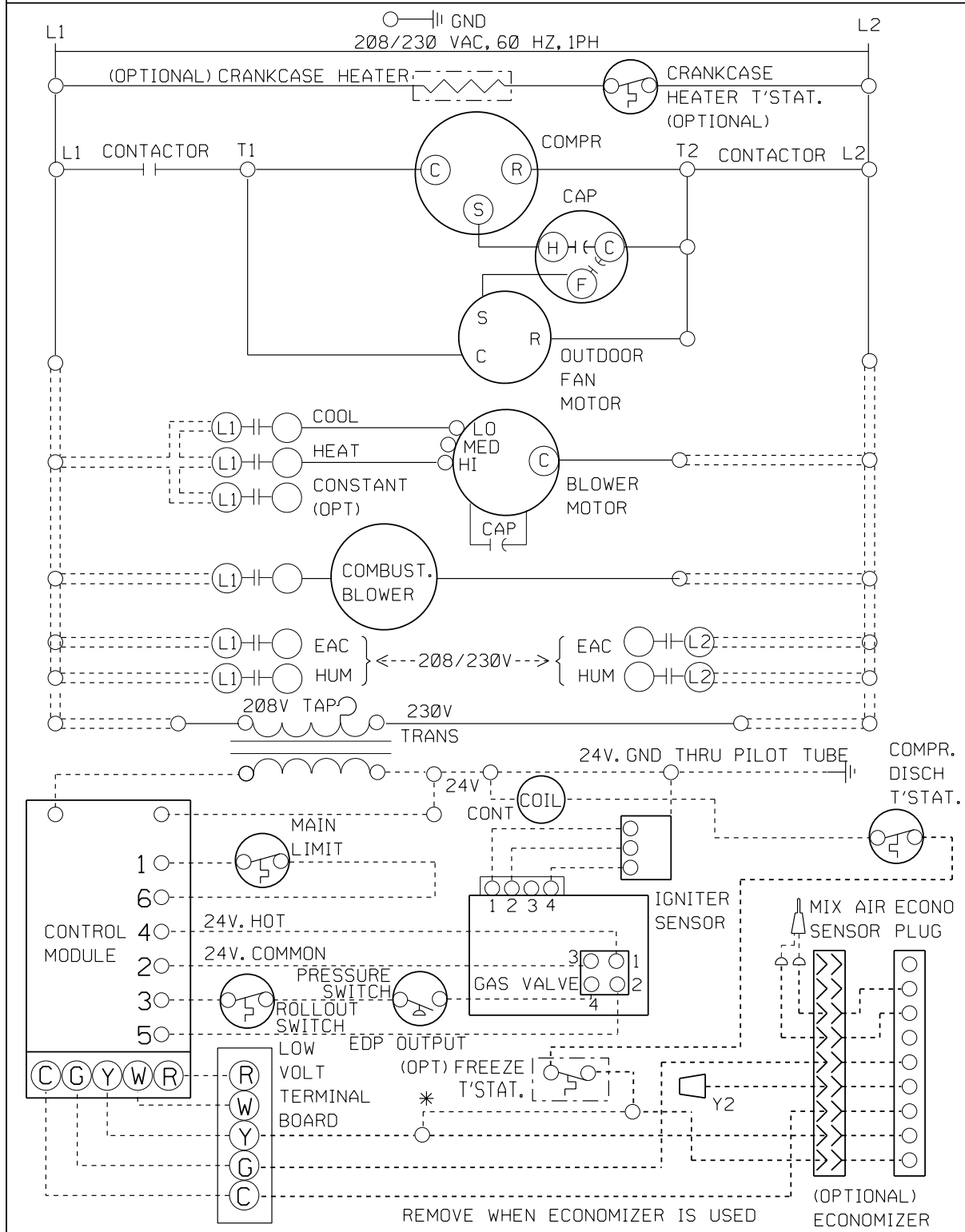

1068002

Wiring Diagram # 32. (Part # 1068003)

CONNECTION WIRING DIAGRAM

DANGER: ELECTRICAL SHOCK HAZARD DISCONNECT POWER BEFORE SERVICING

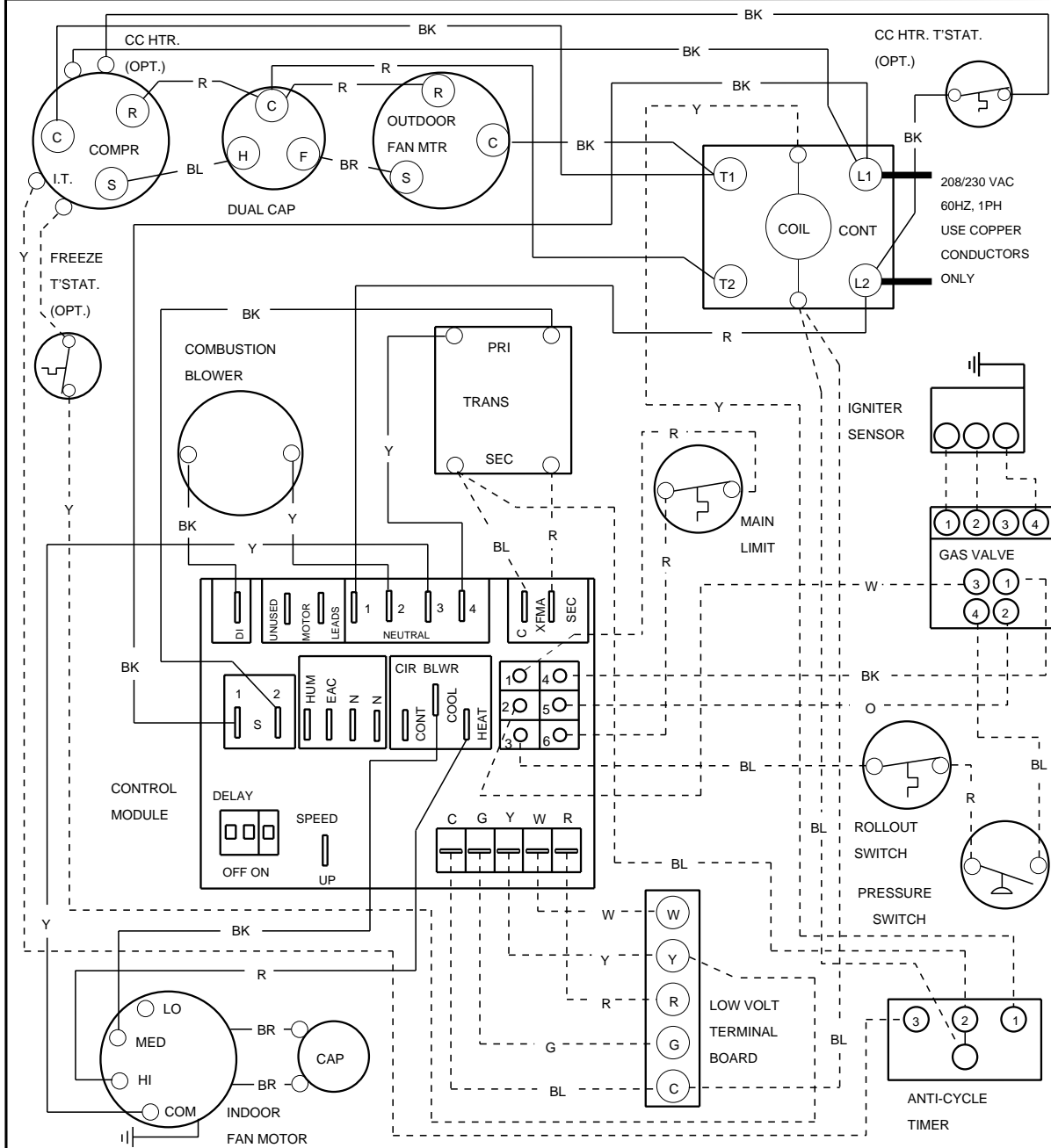

IF ANY OF THE ORIGINAL WIRE AS SUPPLIED WITH THE APPLIANCE MUST BE REPLACED, IT MUST BE REPLACED WITH TYPE AWM-105°C OR ITS EQUIVALENT.

* SEE INSTALLATION INSTRUCTIONS FOR PROPER HEATING AND COOLING CONNECTIONS FOR YOUR UNIT

—	LINE VOLTAGE FACTORY	COLOR CODE :	BLACK BK	GREEN G	WHITE W
—	LINE VOLTAGE FIELD		BLUE BL	ORANGE O	YELLOW Y
- - -	LOW VOLTAGE FACTORY		BROWN BR	RED R	
- - -	LOW VOLTAGE FIELD		GRAY GY	VIOLET V	

1068003

Wiring Diagram # 33. (Part # 1068004)

LADDER WIRING DIAGRAM

DANGER: ELECTRICAL SHOCK HAZARD DISCONNECT POWER BEFORE SERVICING

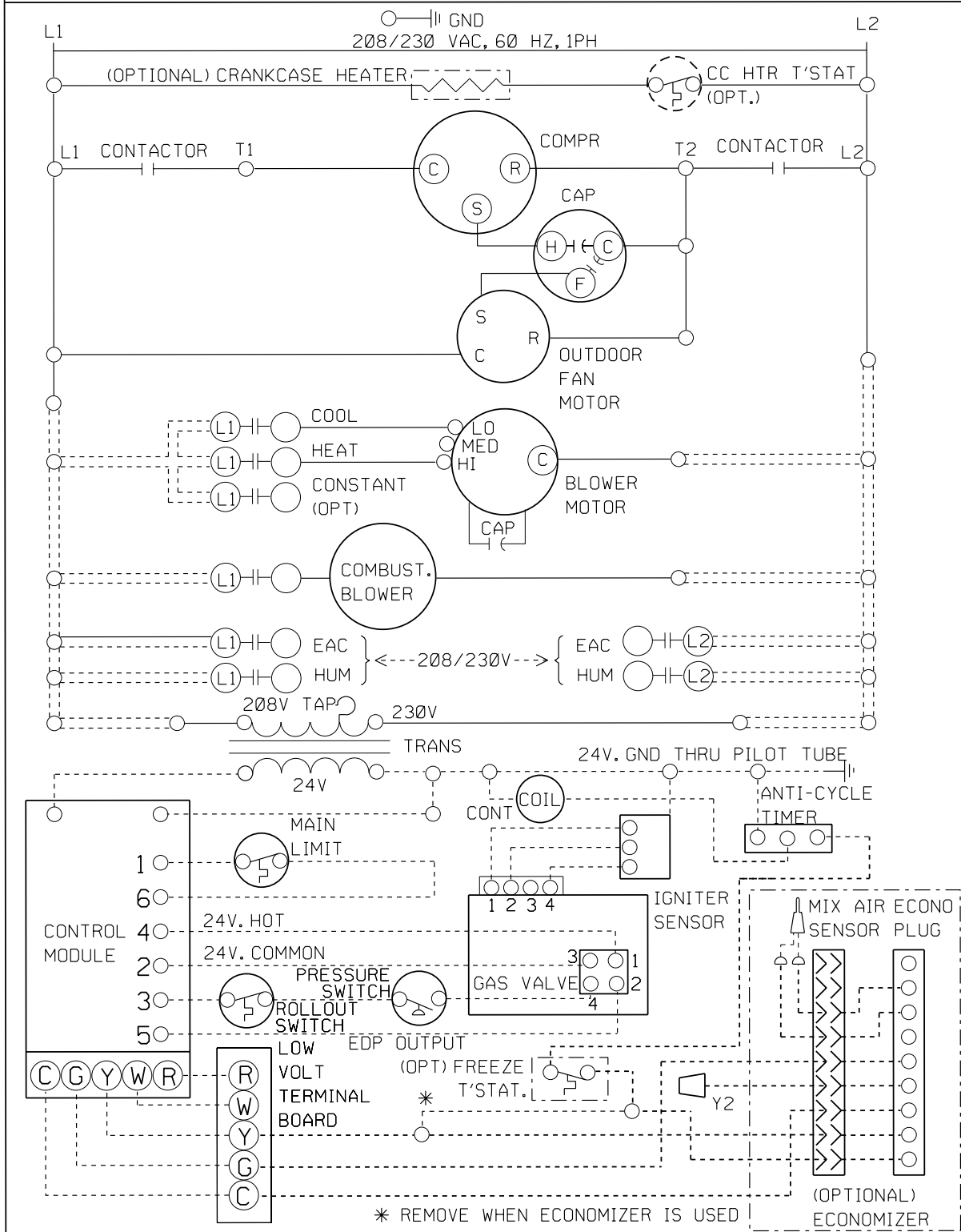

1068004

Wiring Diagram # 34. (Part # 1068005)

LADDER WIRING DIAGRAM

DANGER: ELECTRICAL SHOCK HAZARD DISCONNECT POWER BEFORE SERVICING

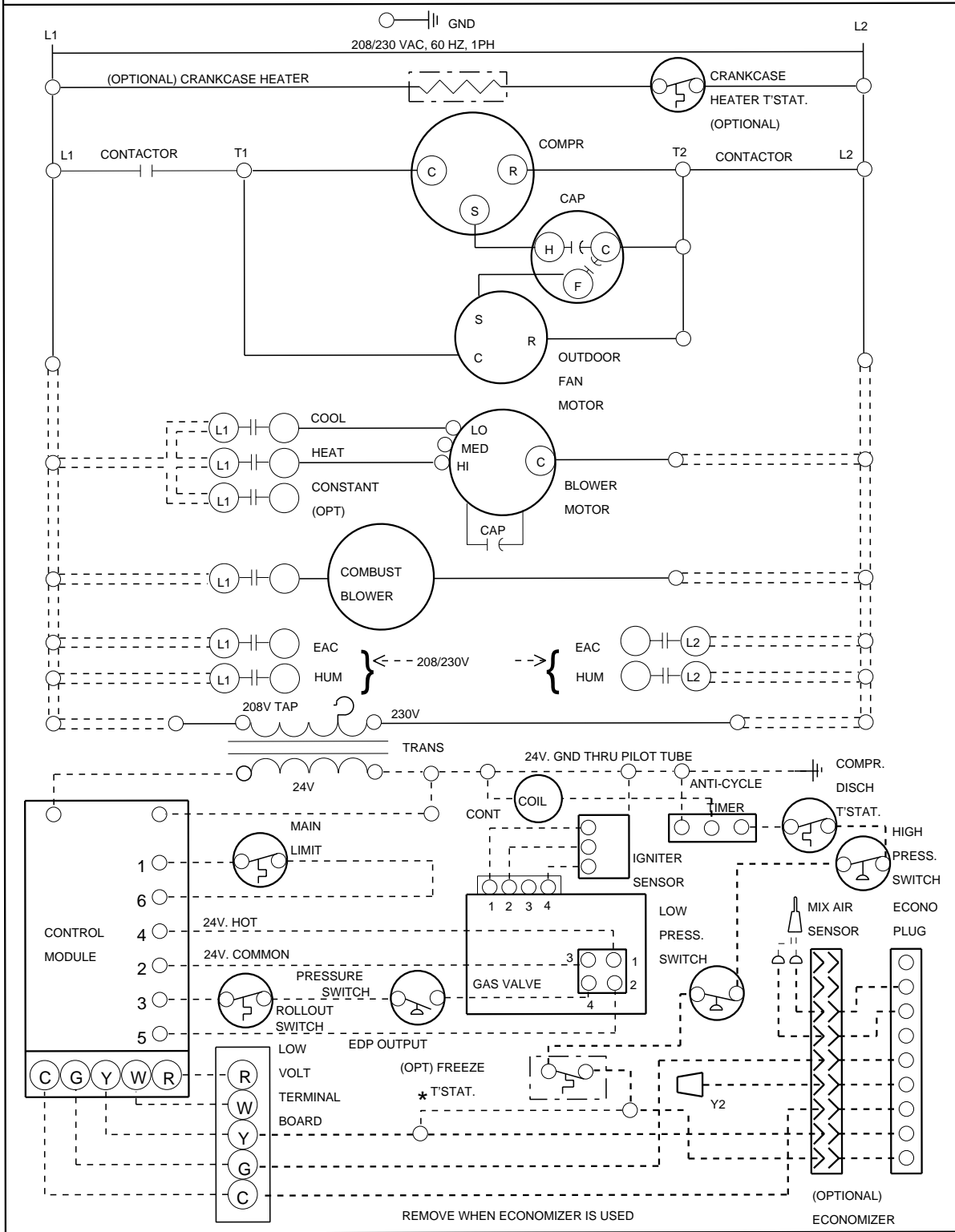

1068005

Wiring Diagram # 35. (Part #1068006)

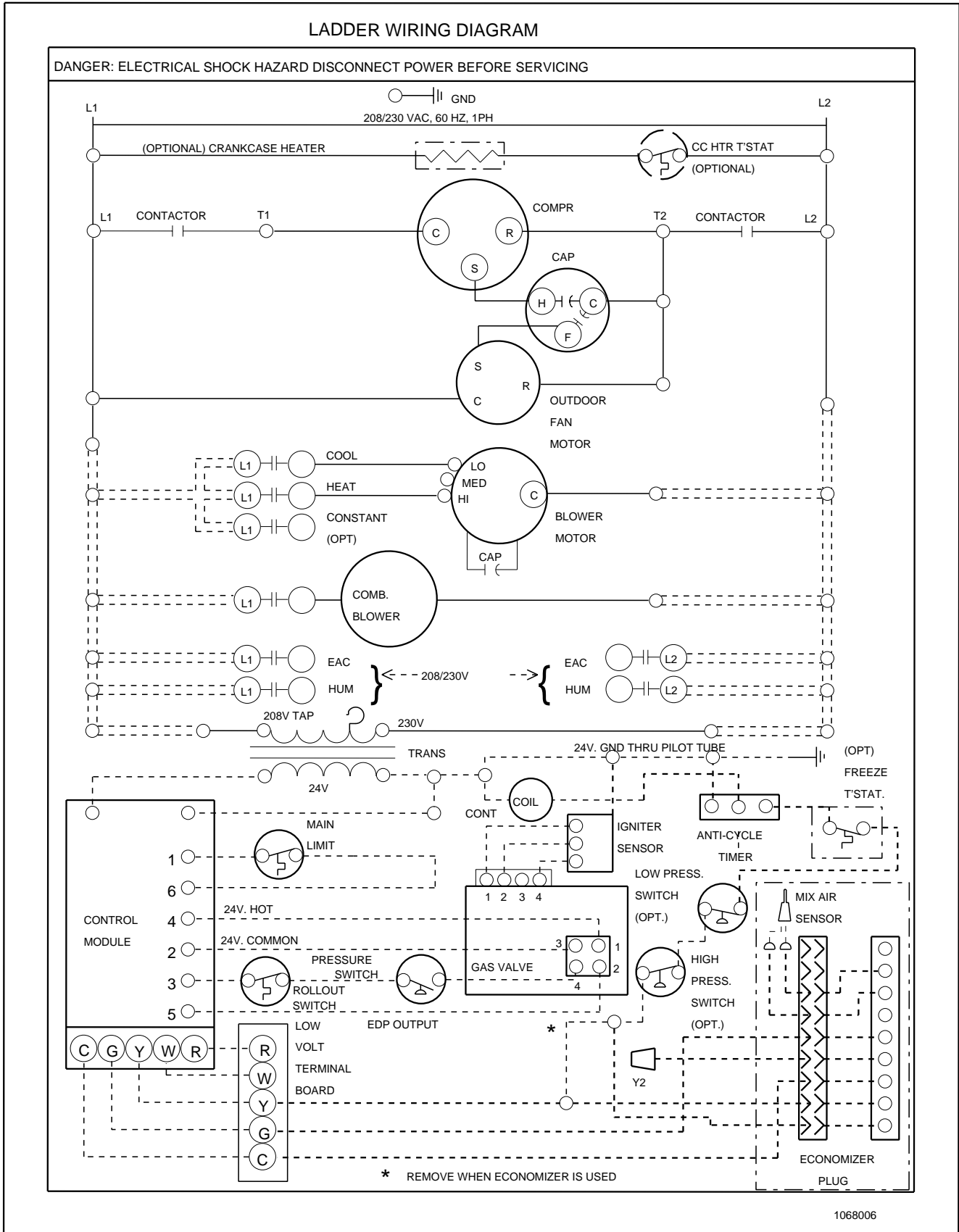

Wiring Diagram # 36. (Part # 1068010)

CONNECTION WIRING DIAGRAM

DANGER: ELECTRICAL SHOCK HAZARD DISCONNECT POWER BEFORE SERVICING

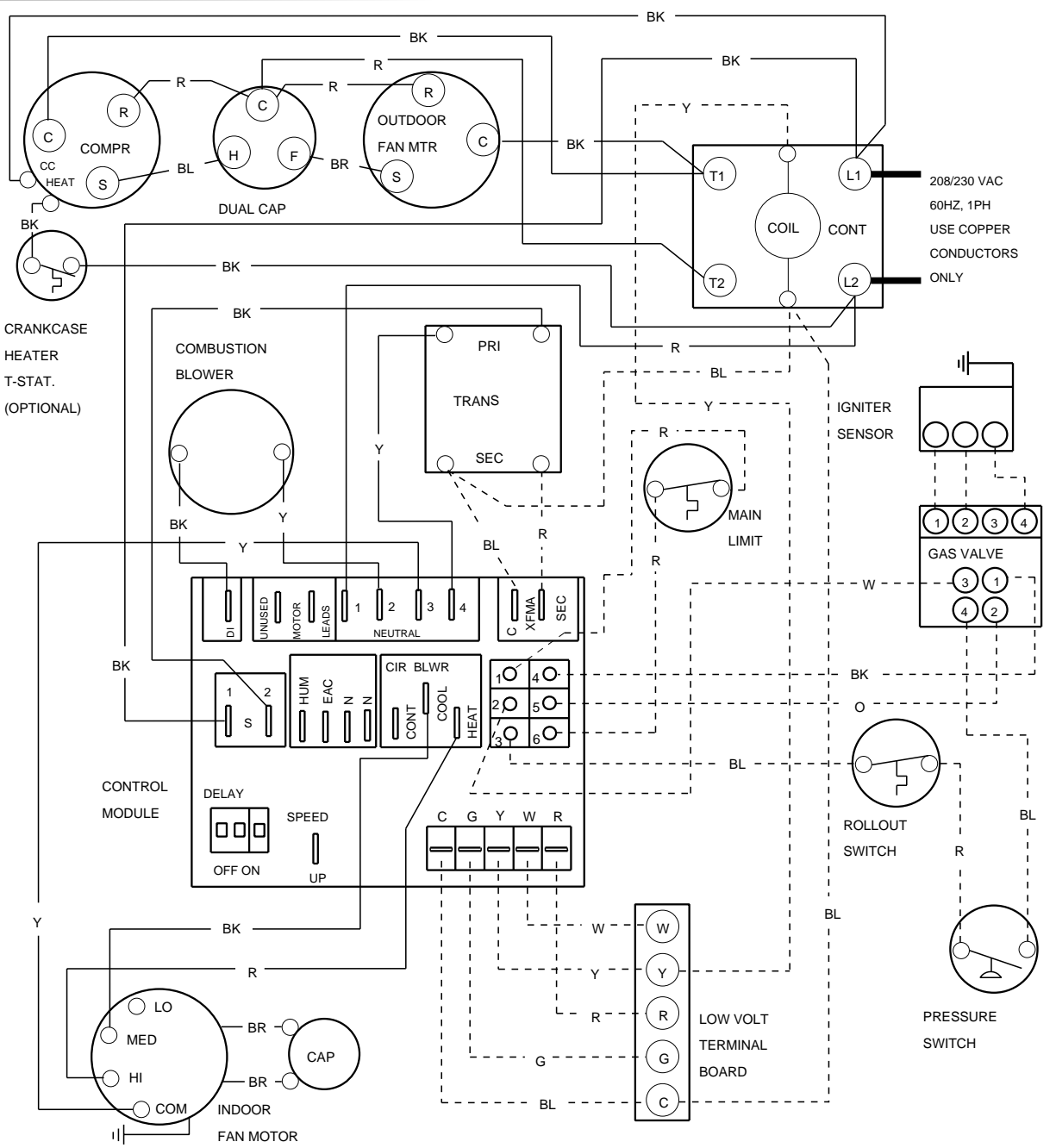

IF ANY OF THE ORIGINAL WIRE AS SUPPLIED WITH THE APPLIANCE MUST BE REPLACED, IT MUST BE REPLACED WITH TYPE AWM-105°C OR ITS EQUIVALENT.

* SEE INSTALLATION INSTRUCTIONS FOR PROPER HEATING AND COOLING CONNECTIONS FOR YOUR UNIT

—	LINE VOLTAGE FACTORY	COLOR CODE :	BLACK BK	GREEN G	WHITE W
—	LINE VOLTAGE FIELD		BLUE BL	ORANGE O	YELLOW Y
- - -	LOW VOLTAGE FACTORY		BROWN BR	RED R	
- - -	LOW VOLTAGE FIELD		GRAY GY	VIOLET V	

1068010

Wiring Diagram # 37. (Part # 1068011)

CONNECTION WIRING DIAGRAM

DANGER: ELECTRICAL SHOCK HAZARD DISCONNECT POWER BEFORE SERVICING

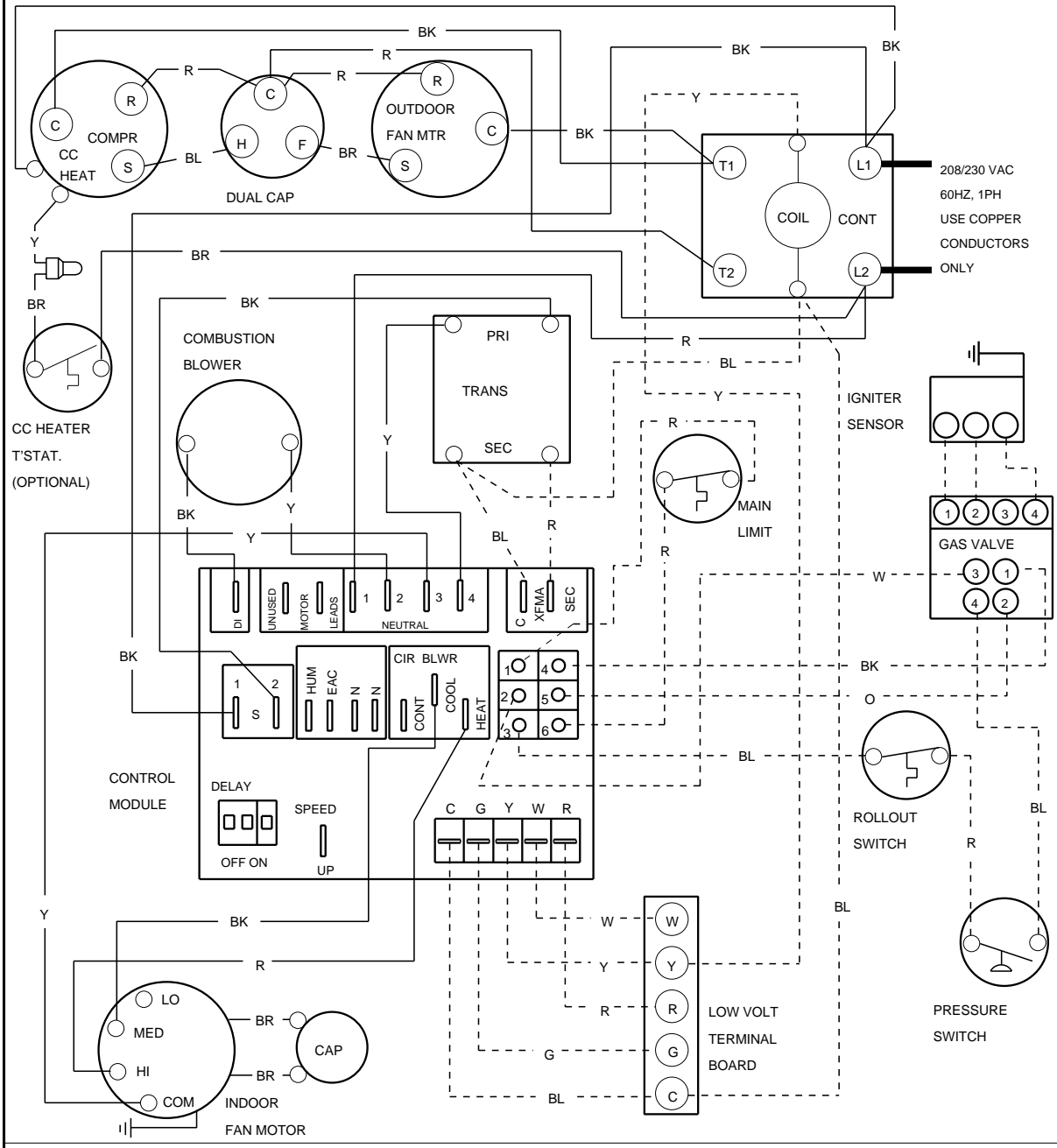

IF ANY OF THE ORIGINAL WIRE AS SUPPLIED WITH THE APPLIANCE MUST BE REPLACED, IT MUST BE REPLACED WITH TYPE AWM-105°C OR ITS EQUIVALENT.

* SEE INSTALLATION INSTRUCTIONS FOR PROPER HEATING AND COOLING CONNECTIONS FOR YOUR UNIT

——	LINE VOLTAGE FACTORY	COLOR CODE	BLACK BK	GREEN G	WHITE W
— — —	LINE VOLTAGE FIELD		BLUE BL	ORANGE O	YELLOW Y
- - -	LOW VOLTAGE FACTORY		BROWN BR	RED R	
- - -	LOW VOLTAGE FIELD		GRAY GY	VIOLET V	

Wiring Diagram # 38. (Part # 1068012)

LADDER WIRING DIAGRAM

DANGER: ELECTRICAL SHOCK HAZARD DISCONNECT POWER BEFORE SERVICING

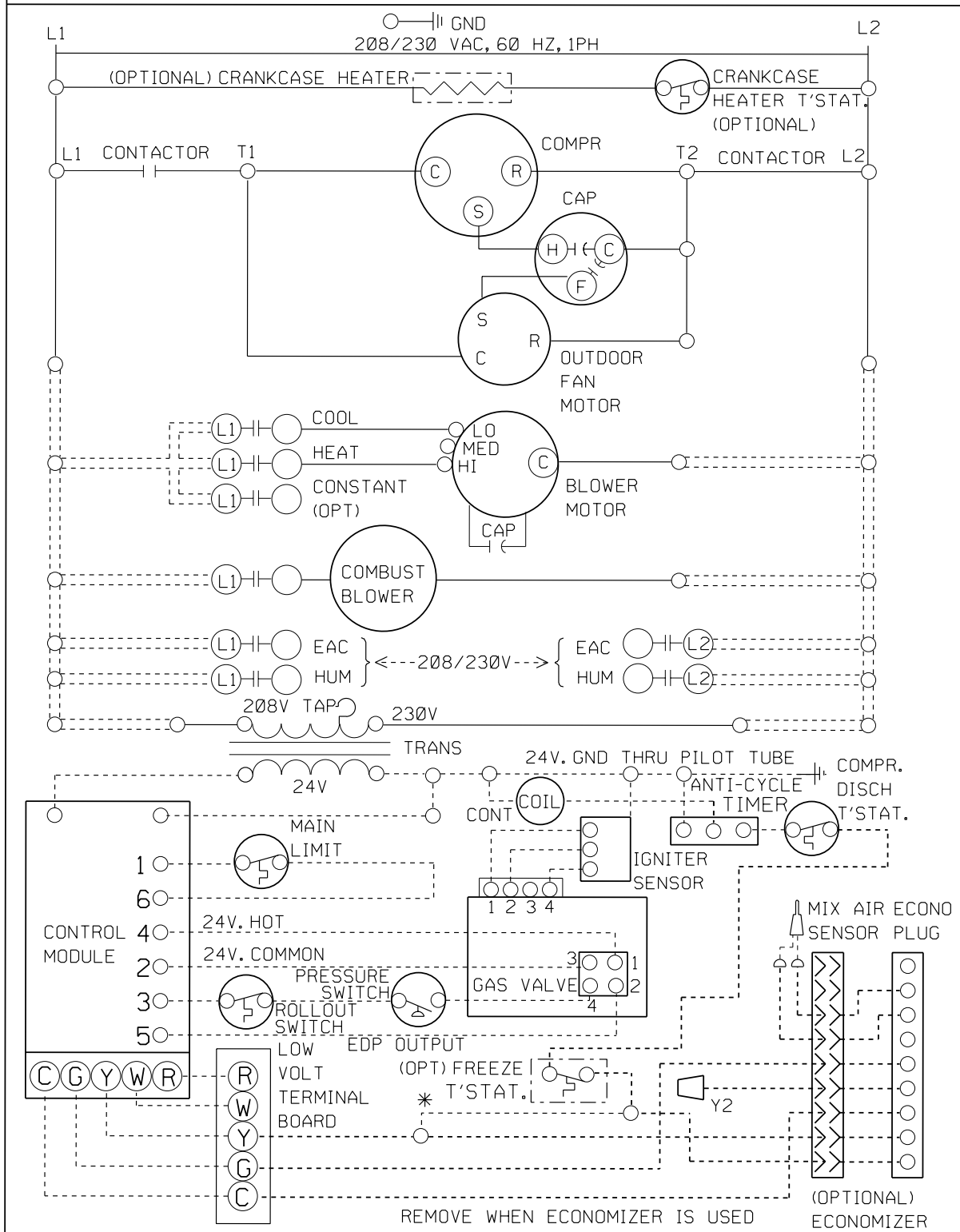

1068012

Wiring Diagram # 39. (Part # 1068013)

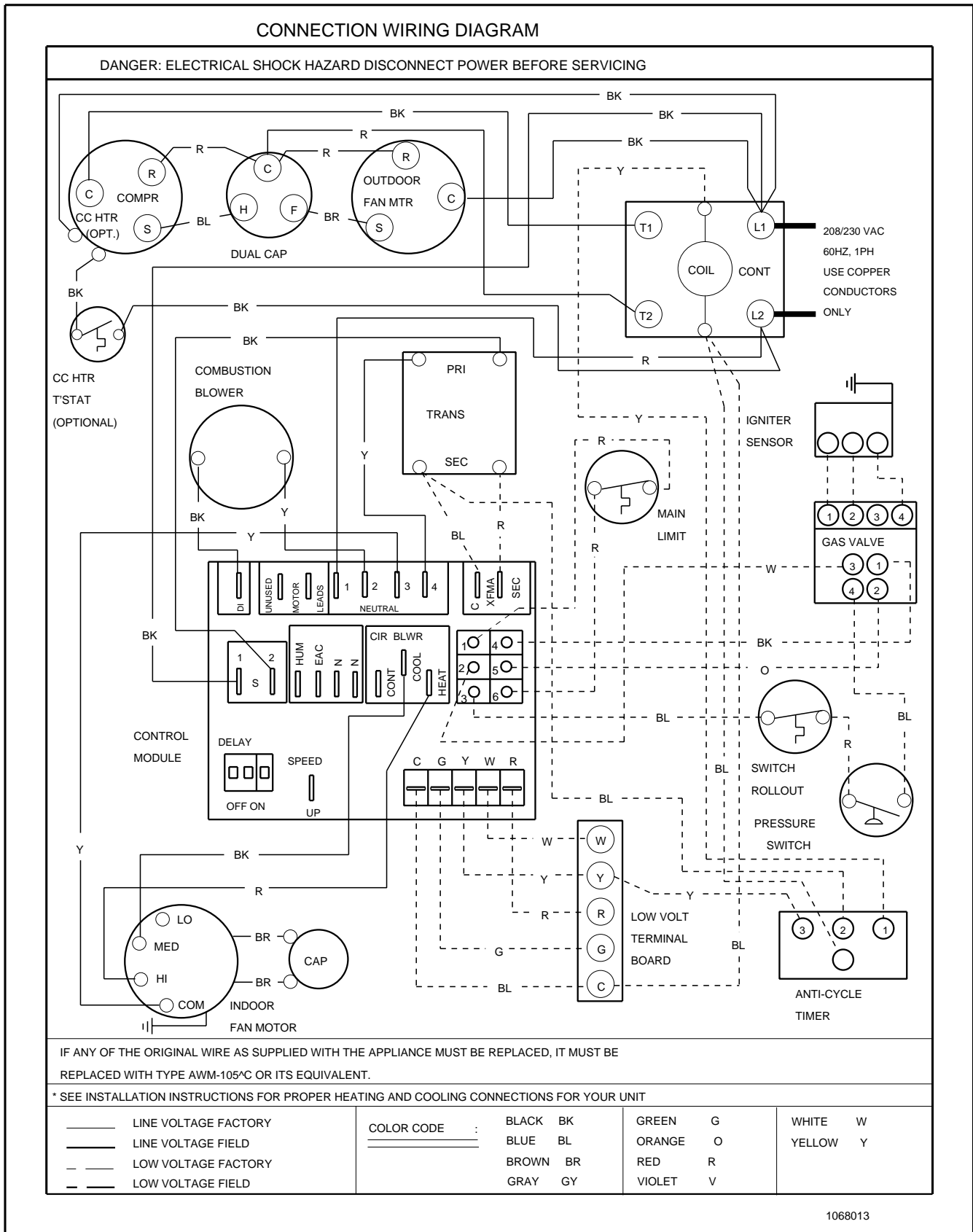

IF ANY OF THE ORIGINAL WIRE AS SUPPLIED WITH THE APPLIANCE MUST BE REPLACED, IT MUST BE REPLACED WITH TYPE AWM-105°C OR ITS EQUIVALENT.

* SEE INSTALLATION INSTRUCTIONS FOR PROPER HEATING AND COOLING CONNECTIONS FOR YOUR UNIT

—	LINE VOLTAGE FACTORY	COLOR CODE :	BLACK BK	GREEN G	WHITE W
—	LINE VOLTAGE FIELD		BLUE BL	ORANGE O	YELLOW Y
—	LOW VOLTAGE FACTORY		BROWN BR	RED R	
—	LOW VOLTAGE FIELD		GRAY GY	VIOLET V	

Wiring Diagram # 41. (Part # 1068015)

CONNECTION WIRING DIAGRAM

DANGER: ELECTRICAL SHOCK HAZARD DISCONNECT POWER BEFORE SERVICING

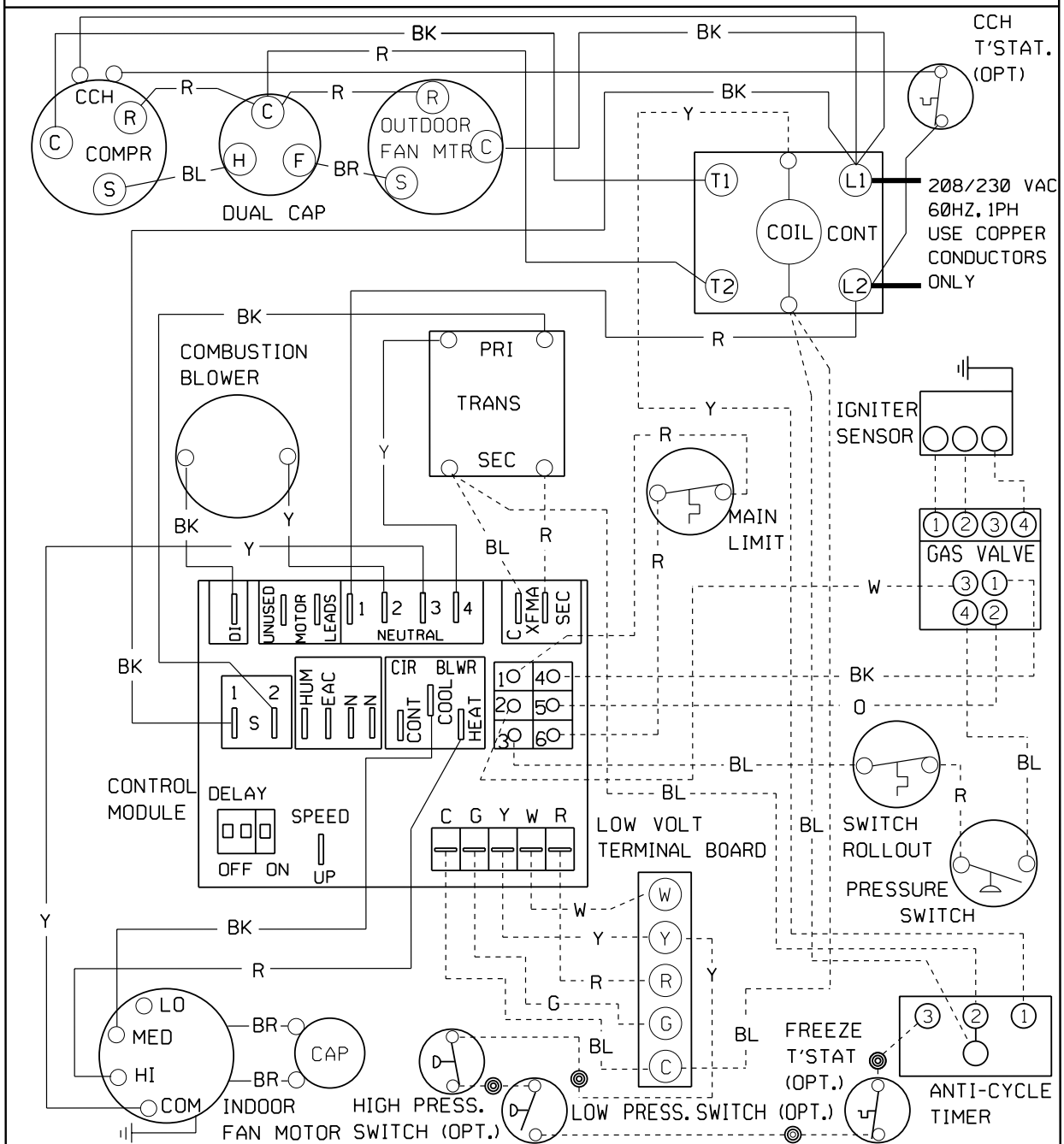

IF ANY OF THE ORIGINAL WIRE AS SUPPLIED WITH THE APPLIANCE MUST BE REPLACED, IT MUST BE REPLACED WITH TYPE AWM-105°C OR ITS EQUIVALENT.

* SEE INSTALLATION INSTRUCTIONS FOR PROPER HEATING AND COOLING CONNECTIONS FOR YOUR UNIT

—	LINE VOLTAGE FACTORY	COLOR CODE :	BLACK	BK	GREEN	G	WHITE	W
—	LINE VOLTAGE FIELD		BLUE	BL	ORANGE	O	YELLOW	Y
- - -	LOW VOLTAGE FACTORY		BROWN	BR	RED	R		
- - -	LOW VOLTAGE FIELD		GRAY	GY	VIOLET	V		

1068015

Wiring Diagram # 42. (Part # 1068243)

LADDER WIRING DIAGRAM

DANGER: ELECTRICAL SHOCK HAZARD DISCONNECT POWER BEFORE SERVICING

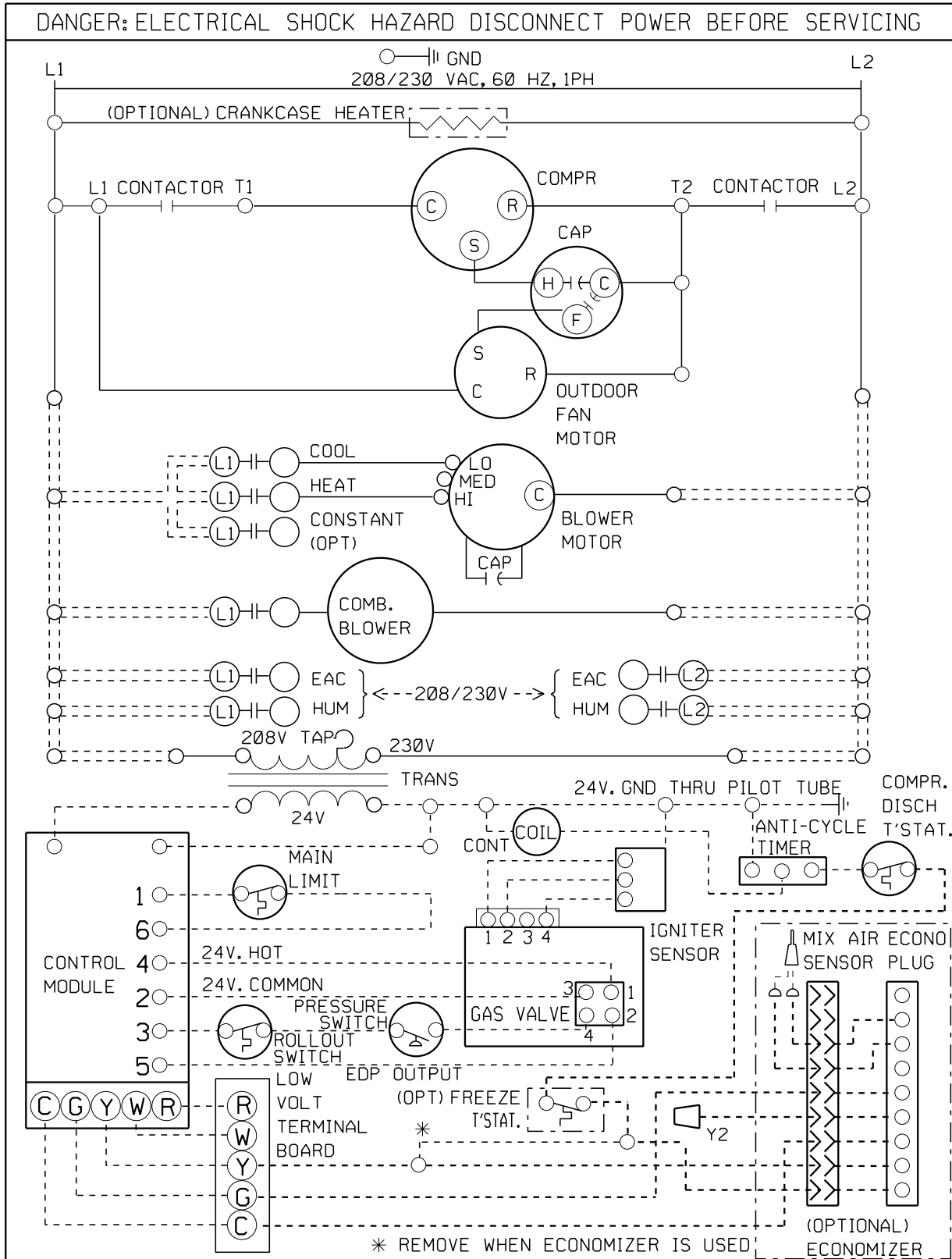

1068243

Wiring Diagram # 43. (Part # 1068244)

CONNECTION WIRING DIAGRAM

DANGER: ELECTRICAL SHOCK HAZARD DISCONNECT POWER BEFORE SERVICING

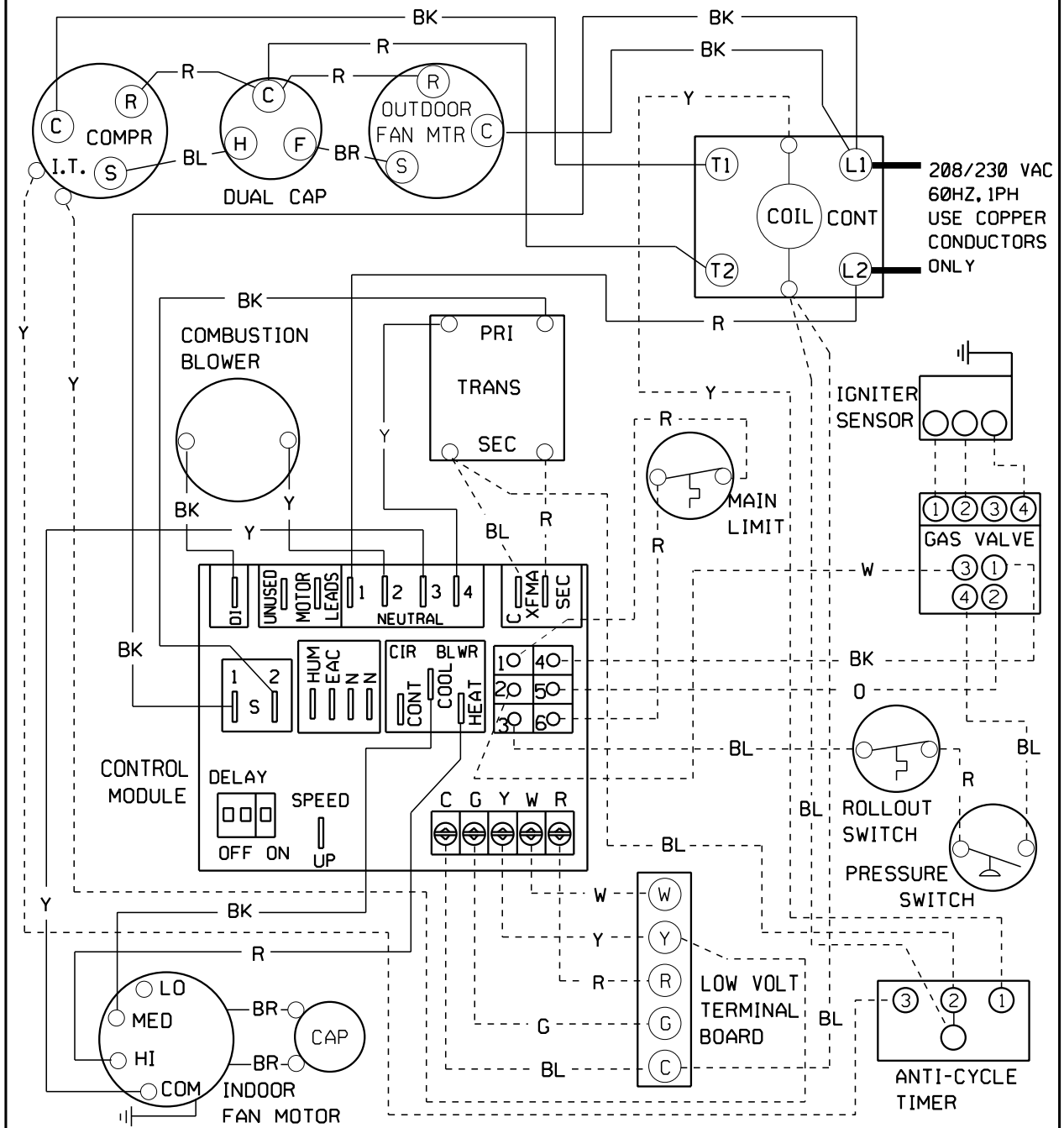

IF ANY OF THE ORIGINAL WIRE AS SUPPLIED WITH THE APPLIANCE MUST BE REPLACED, IT MUST BE REPLACED WITH TYPE AWM-105°C OR ITS EQUIVALENT.

* SEE INSTALLATION INSTRUCTIONS FOR PROPER HEATING AND COOLING CONNECTIONS FOR YOUR UNIT

— LINE VOLTAGE FACTORY - - - LOW VOLTAGE FACTORY = = = INTERNAL CIRCUIT
 — LINE VOLTAGE FIELD - - - LOW VOLTAGE FIELD BOARD WIRING

COLOR CODE:	GREEN	G	BLACK	BK	BROWN	BR	RED	R	WHITE	W
	ORANGE	O	BLUE	BL	GRAY	GY	VIOLET	V	YELLOW	Y

Wiring Diagram # 44. (Part # 1068278)

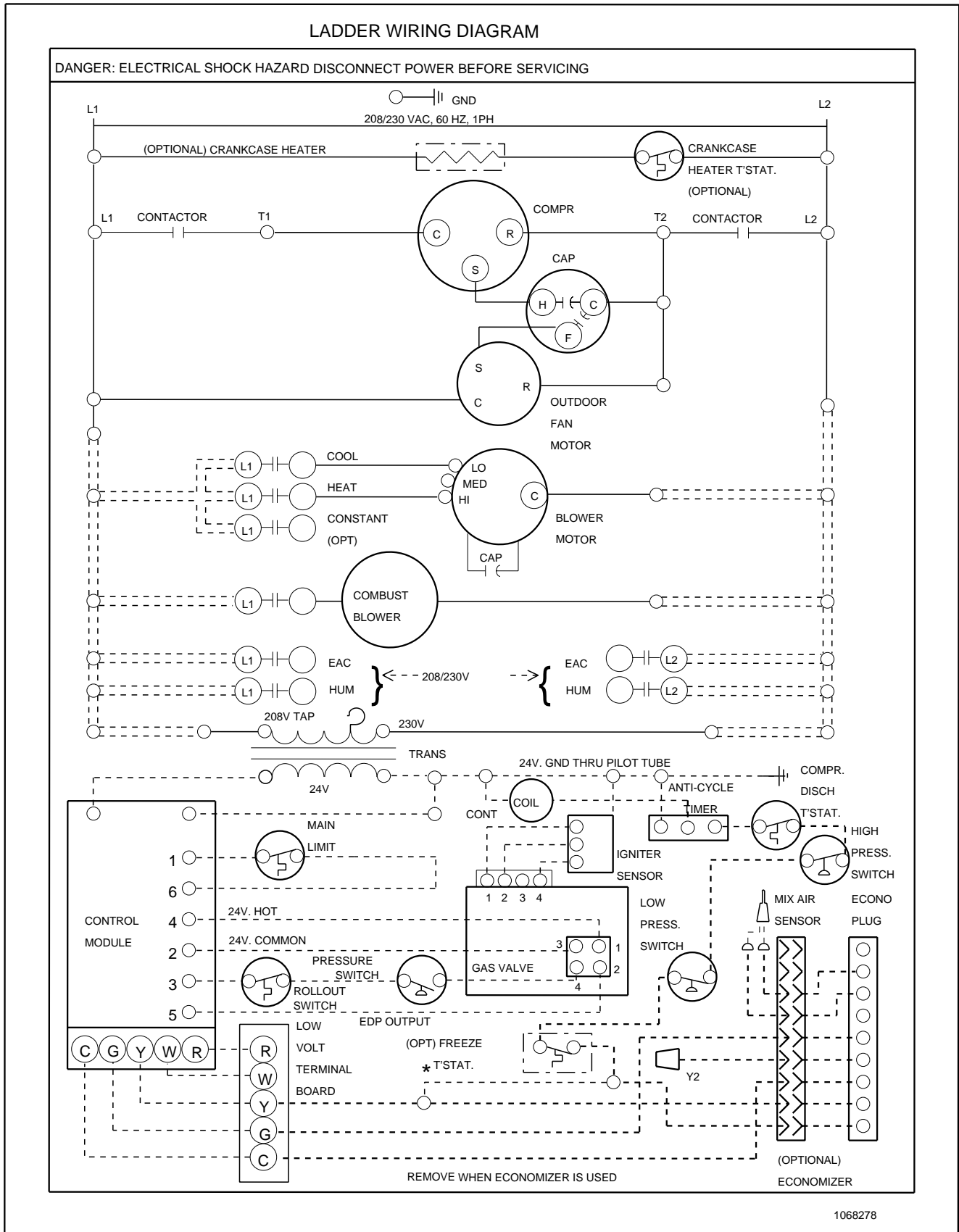

Wiring Diagram # 45. (Part # 1068279)

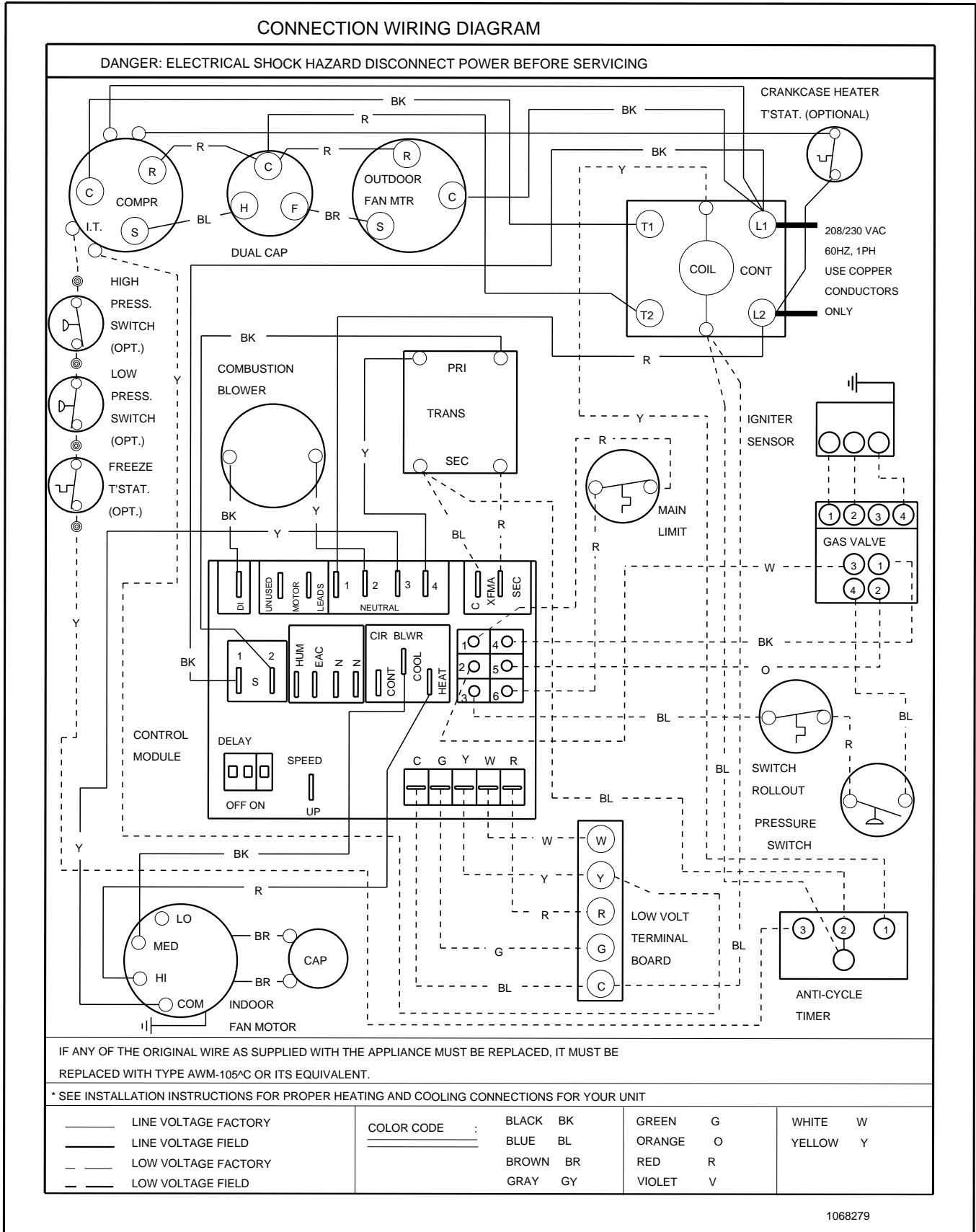

Wiring Diagram # 46. (Part # 4531404W)

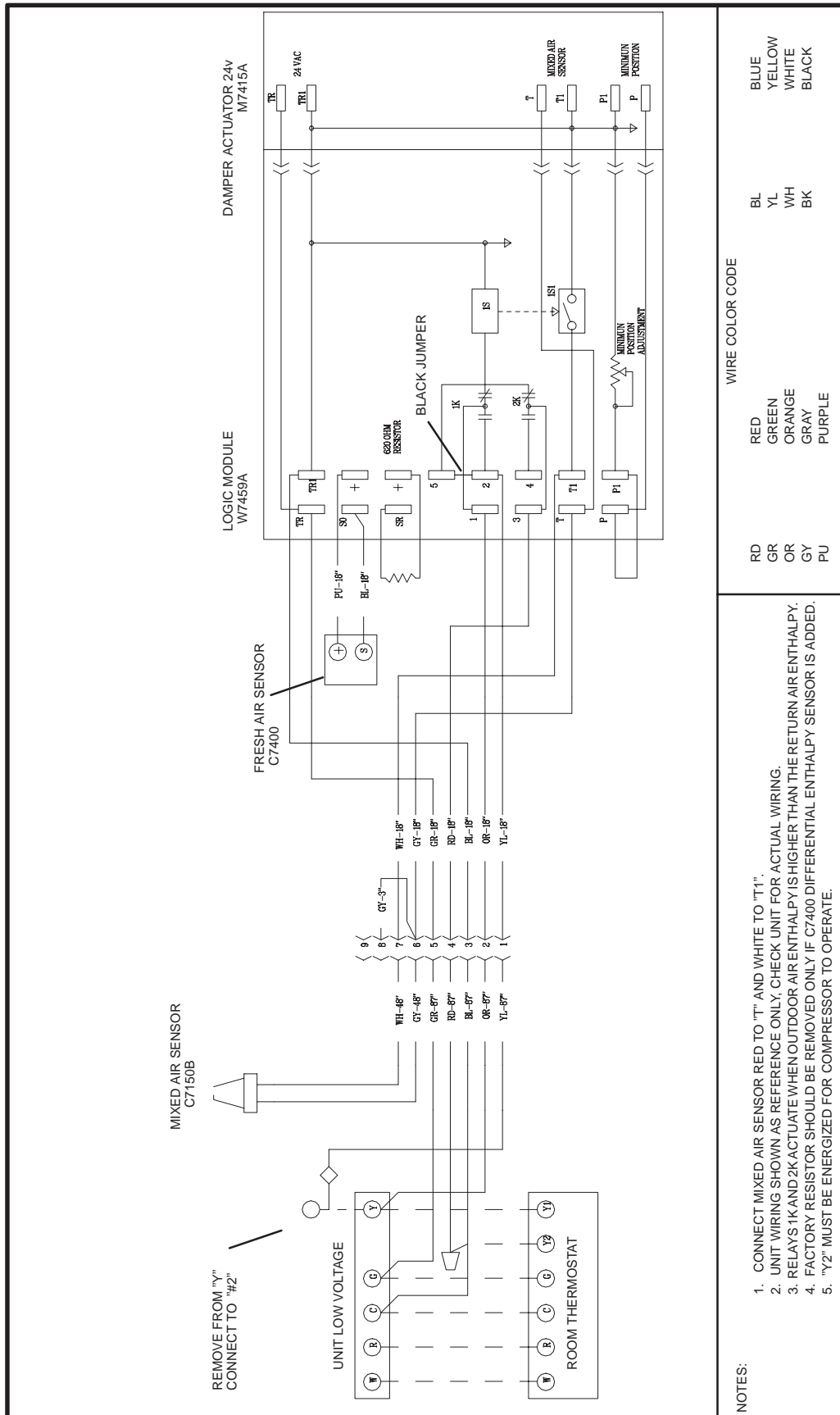

Wiring Diagram # 47. (Part # 4531504W)

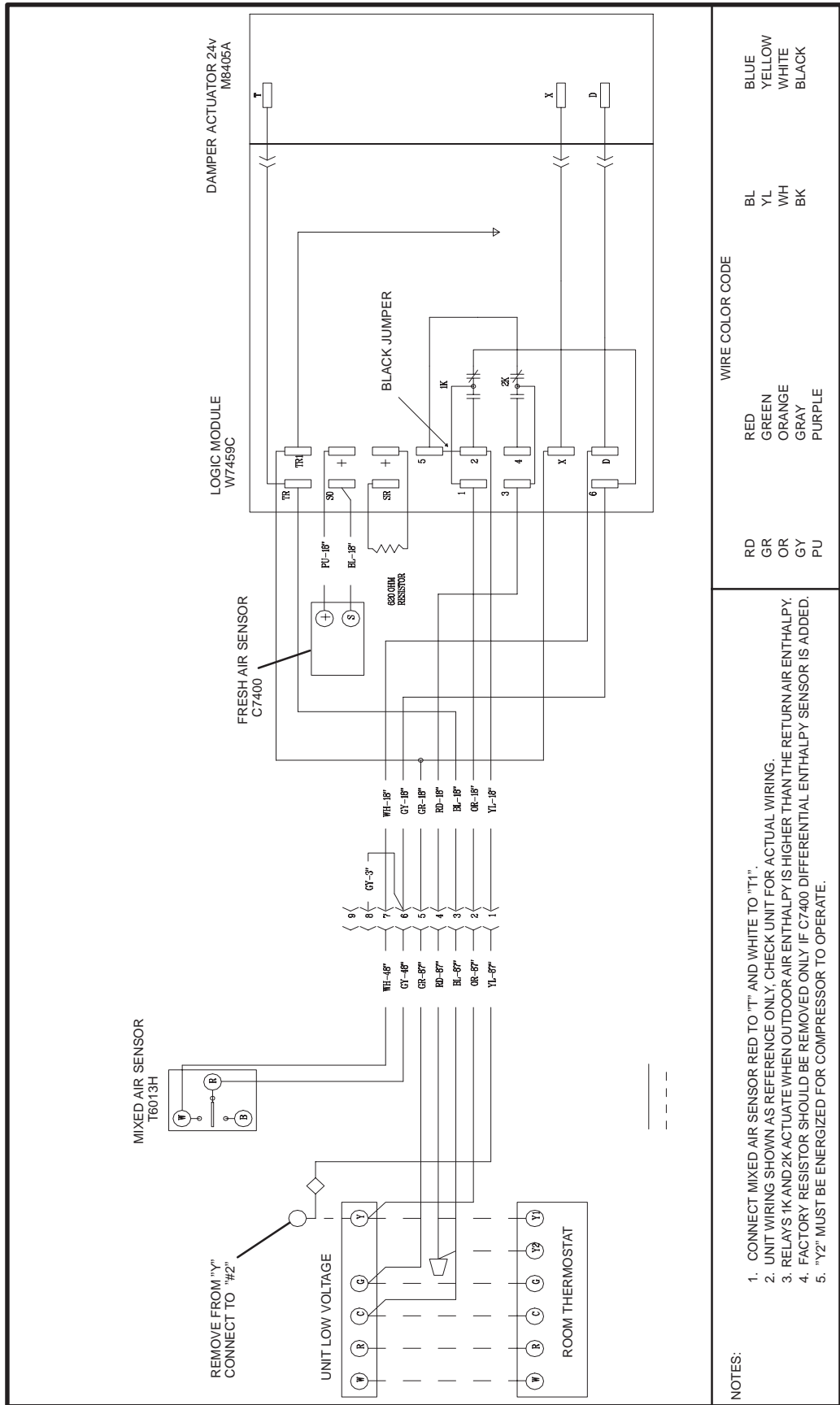

Wiring Diagram # 48. (Part # 4532403W)

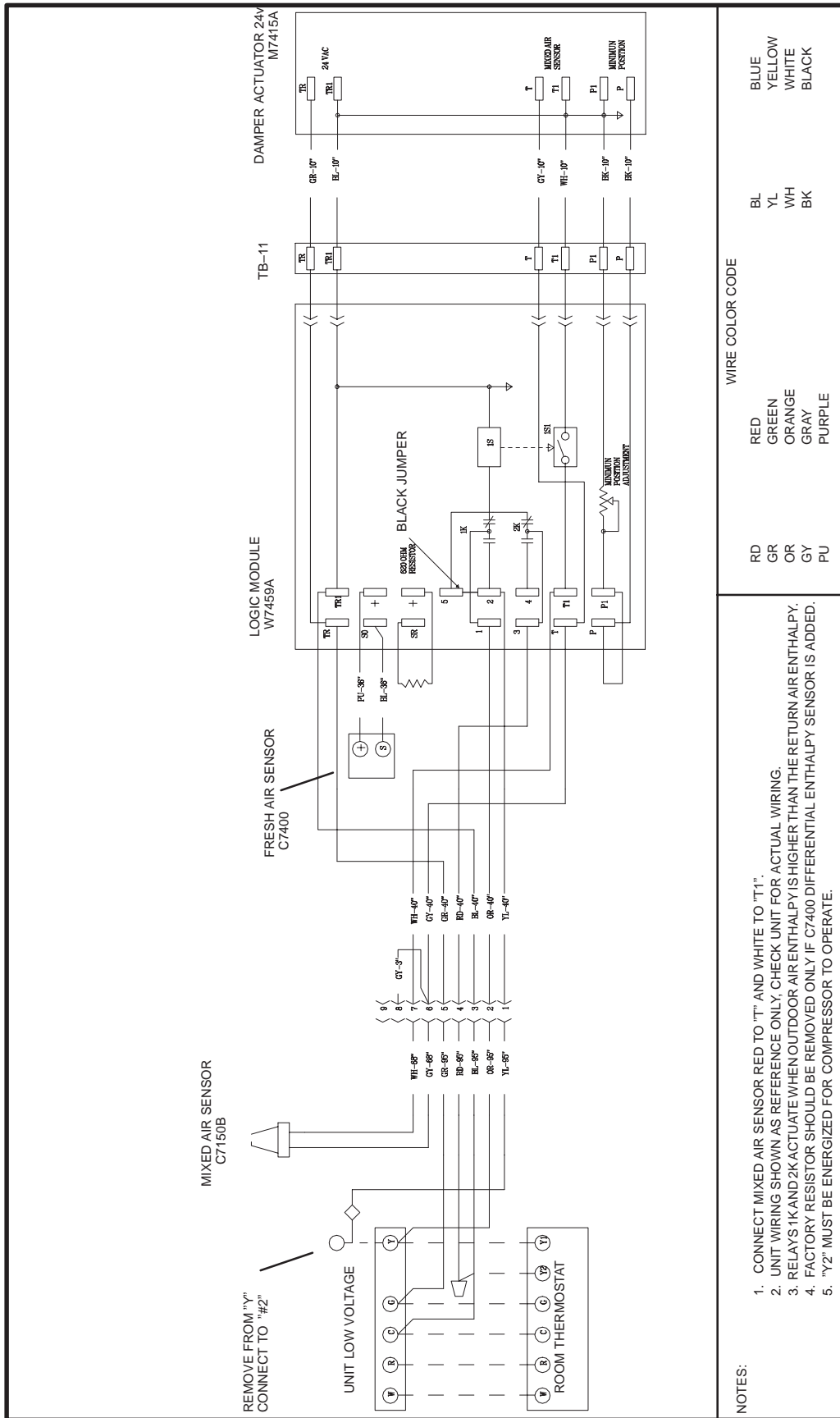

- NOTES:**
1. CONNECT MIXED AIR SENSOR RED TO "T" AND WHITE TO "T1".
 2. UNIT WIRING SHOWN AS REFERENCE ONLY; CHECK UNIT FOR ACTUAL WIRING.
 3. RELAYS 1K AND 2K ACTUATE WHEN OUTDOOR AIR ENTHALPY IS HIGHER THAN THE RETURN AIR ENTHALPY.
 4. FACTORY RESISTOR SHOULD BE REMOVED ONLY IF C7400 DIFFERENTIAL ENTHALPY SENSOR IS ADDED.
 5. "Y2" MUST BE ENERGIZED FOR COMPRESSOR TO OPERATE.

Wiring Diagram # 49. (Part # 4532404W)

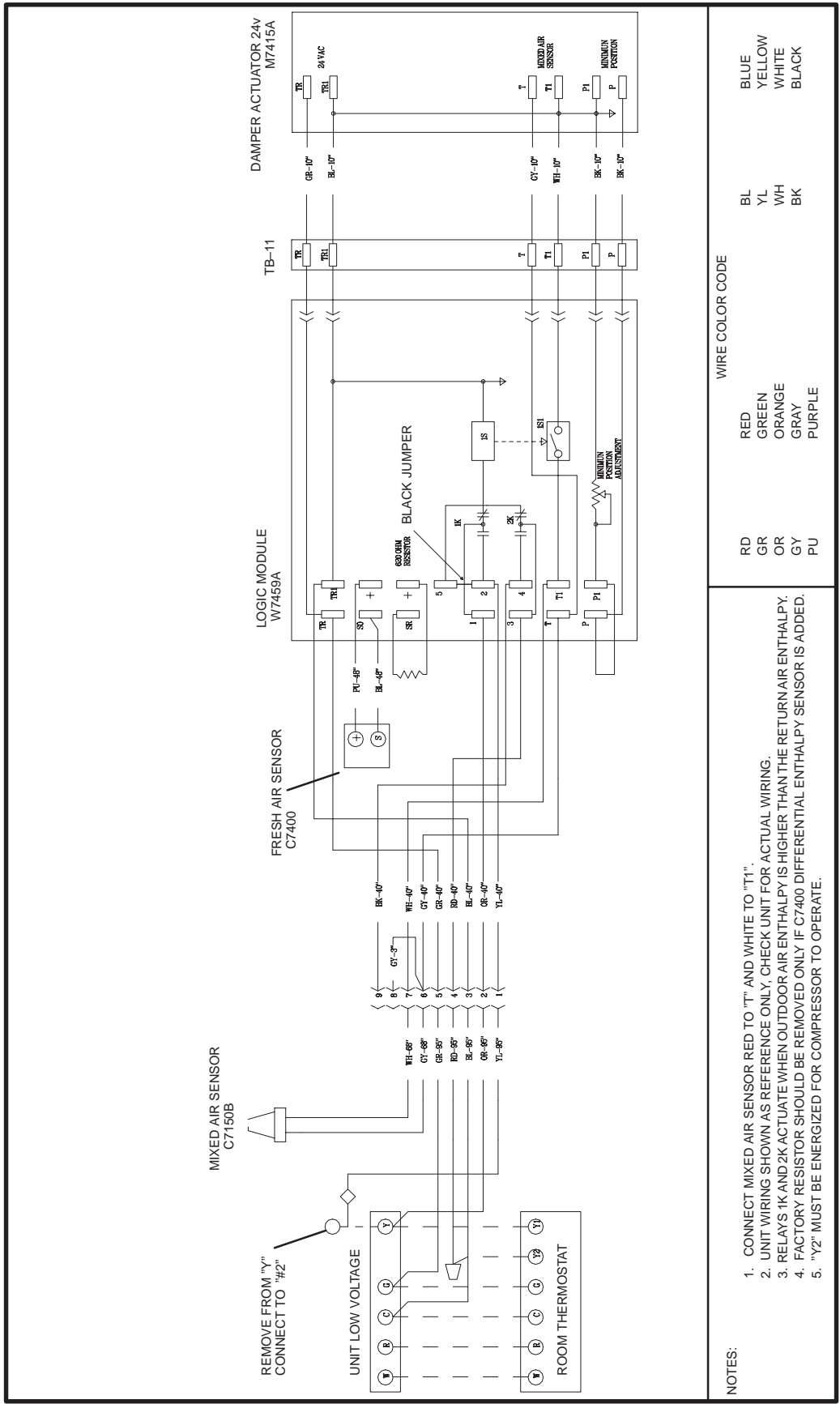

- NOTES:**
1. CONNECT MIXED AIR SENSOR RED TO "T" AND WHITE TO "T1".
 2. UNIT WIRING SHOWN AS REFERENCE ONLY, CHECK UNIT FOR ACTUAL WIRING.
 3. RELAYS 1K AND 2K ACTUATE WHEN OUTDOOR AIR ENTHALPY IS HIGHER THAN THE RETURN AIR ENTHALPY.
 4. FACTORY RESISTOR SHOULD BE REMOVED ONLY IF C7400 DIFFERENTIAL ENTHALPY SENSOR IS ADDED.
 5. "Y2" MUST BE ENERGIZED FOR COMPRESSOR TO OPERATE.

Wiring Diagram # 50. (Part # 4532503W)

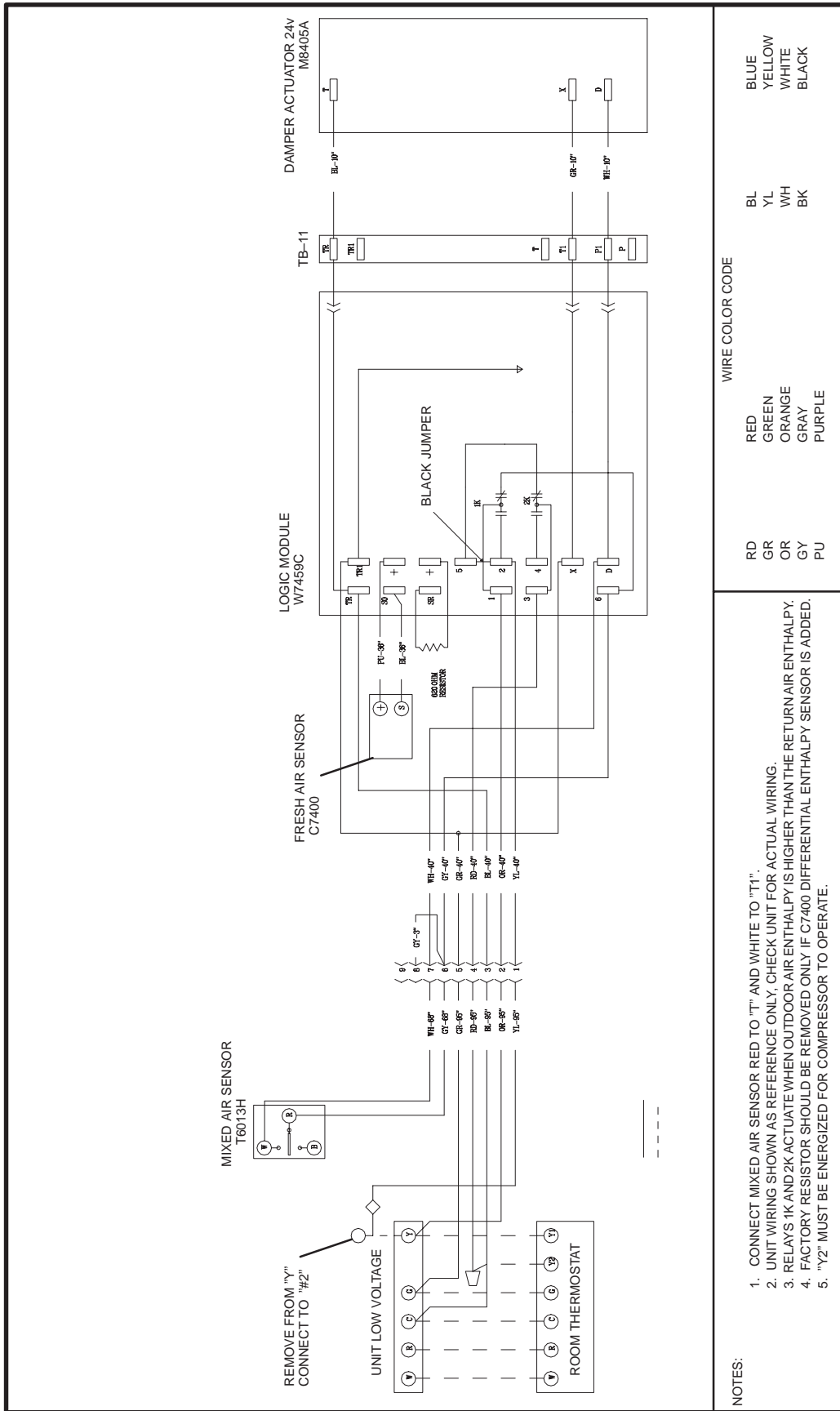

Wiring Diagram # 51. (Part # 4532504W)

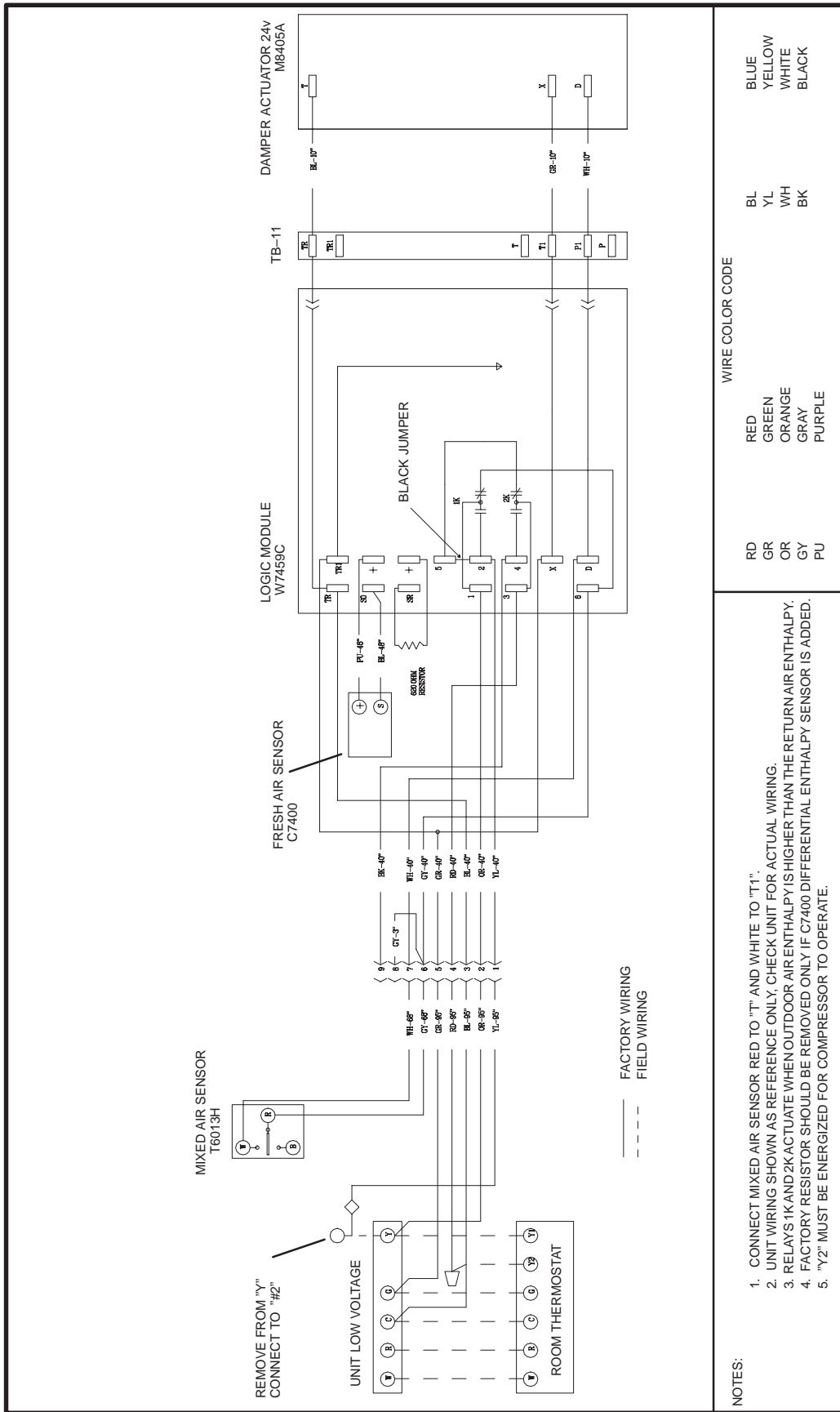

Honeywell S8600M Ignition System Troubleshooting Chart

HONEYWELL S8600M SPARK TO PILOT IGNITION

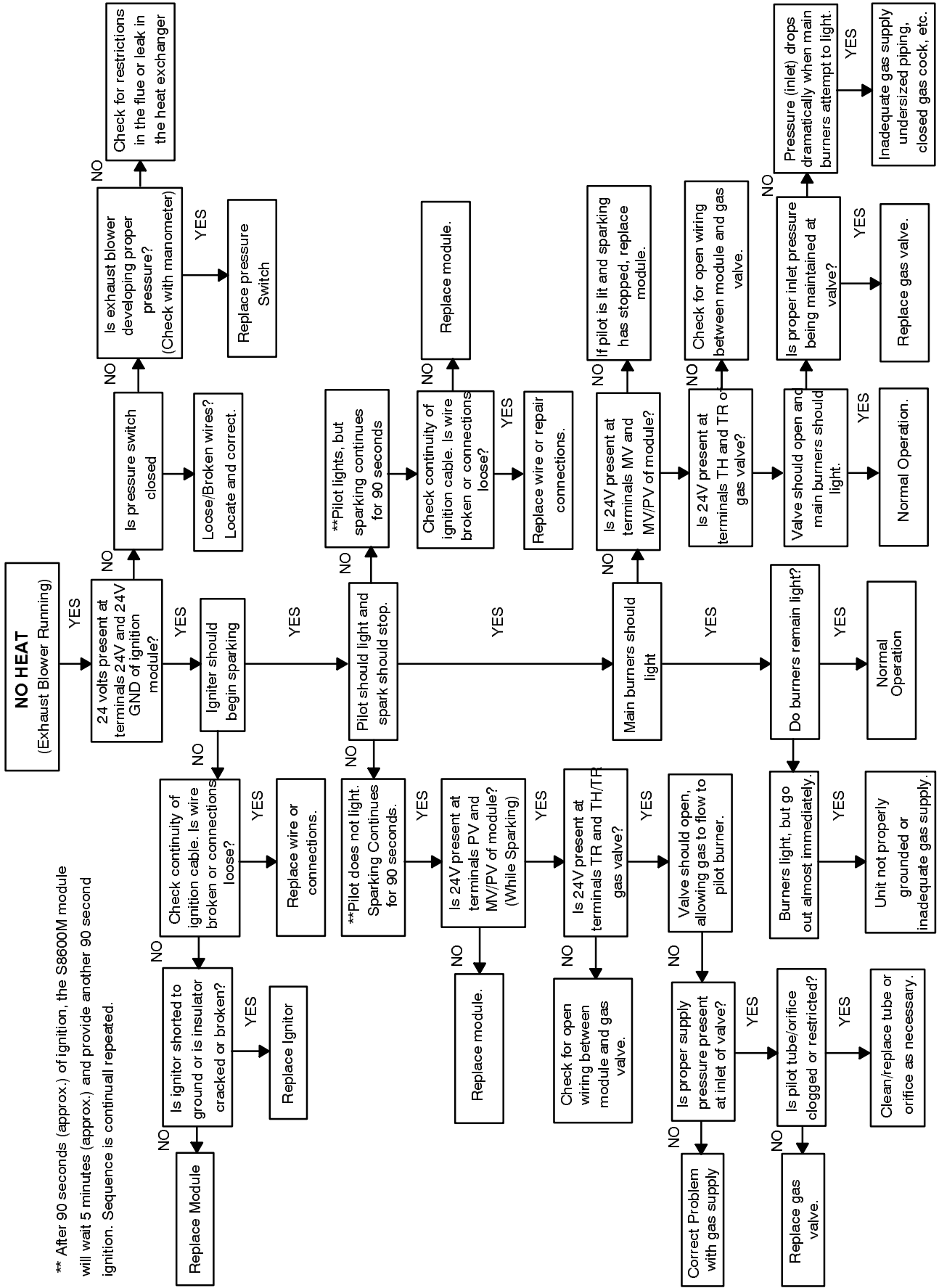

** After 90 seconds (approx.) of ignition, the S8600M module will wait 5 minutes (approx.) and provide another 90 second ignition. Sequence is continual repeated.

Honeywell SV9500M "SMART VALVE" Sequence of Operation

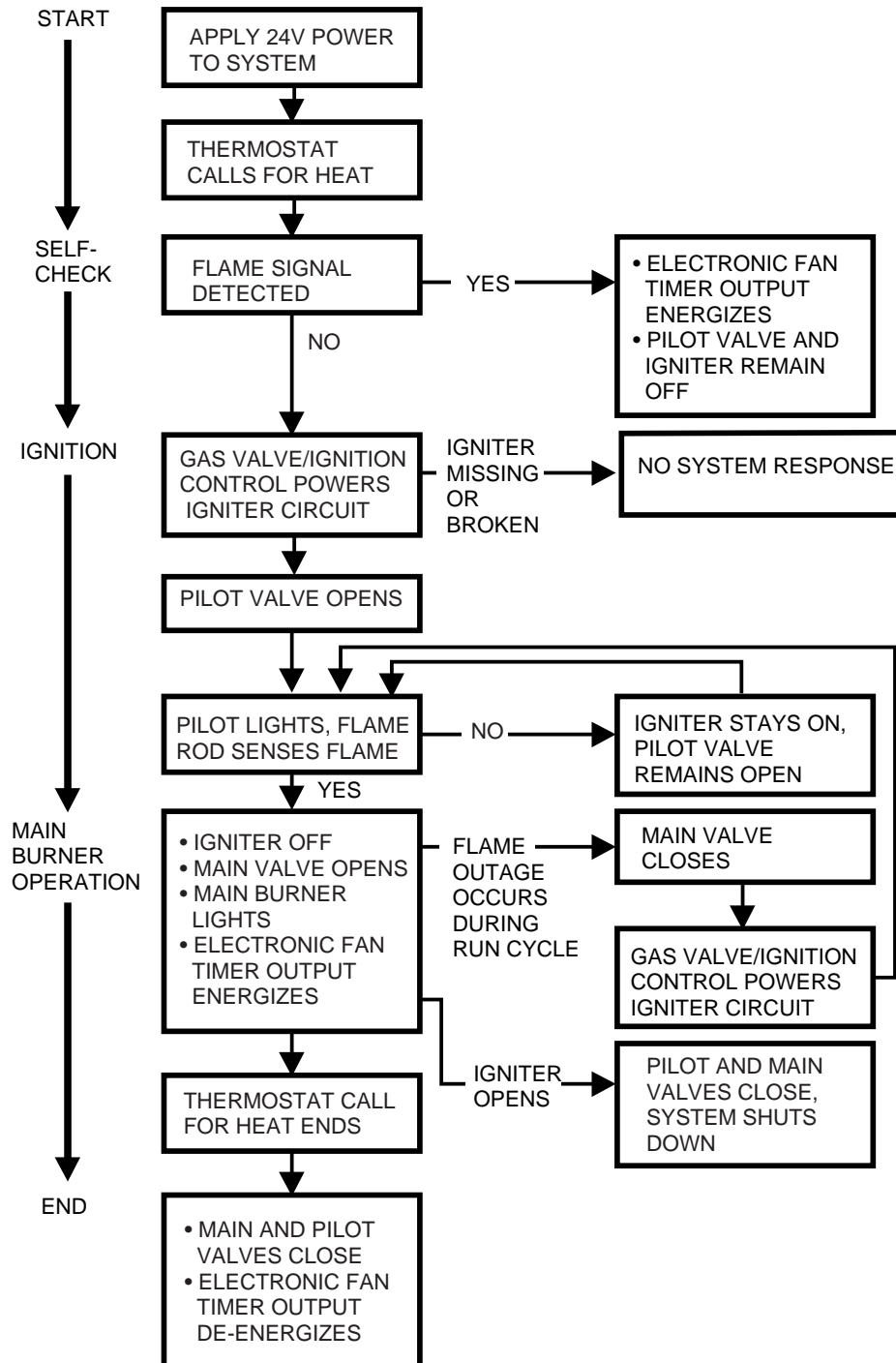

Honeywell SV9500M "SMART VALVE" Troubleshooting Chart

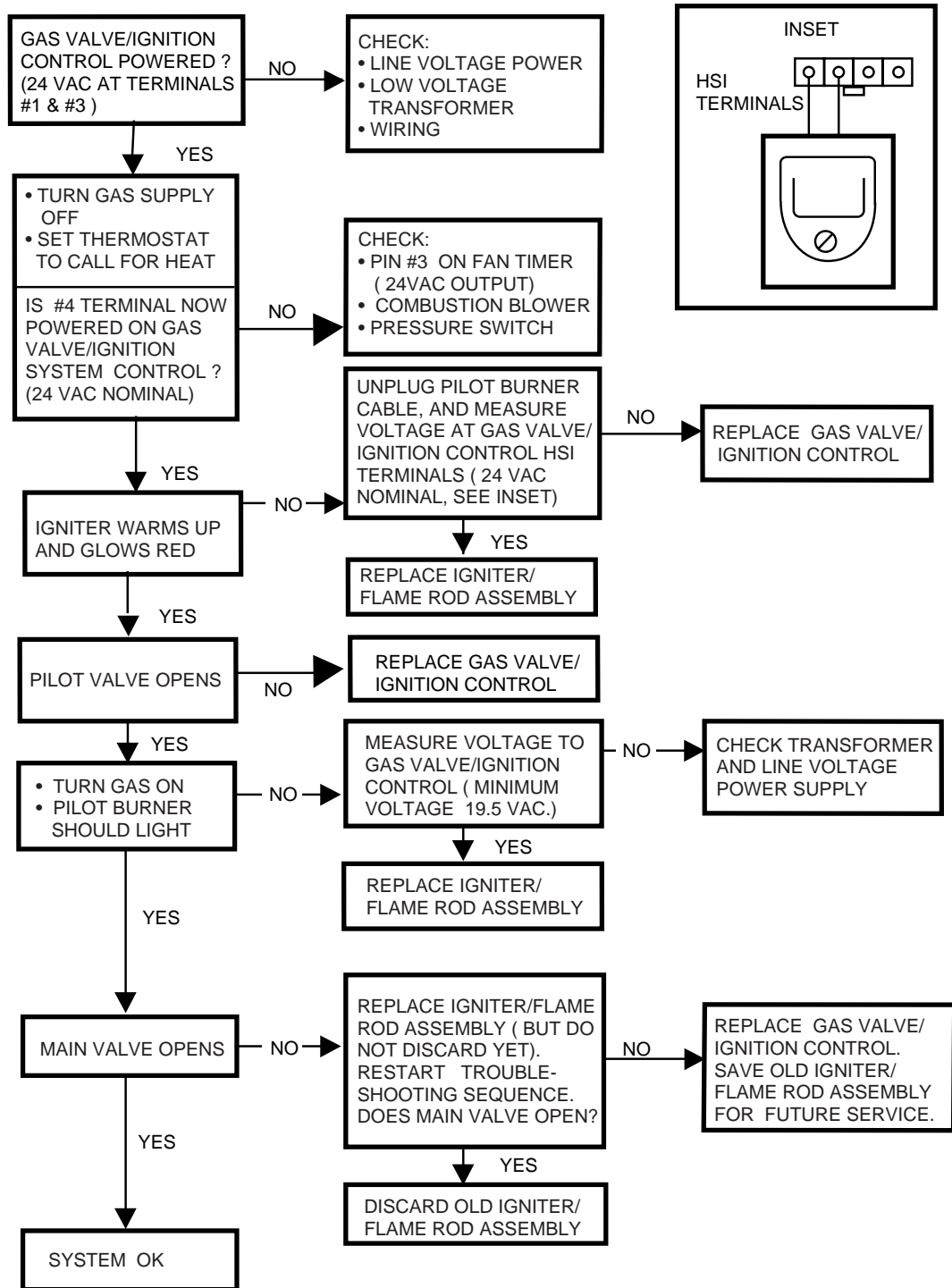

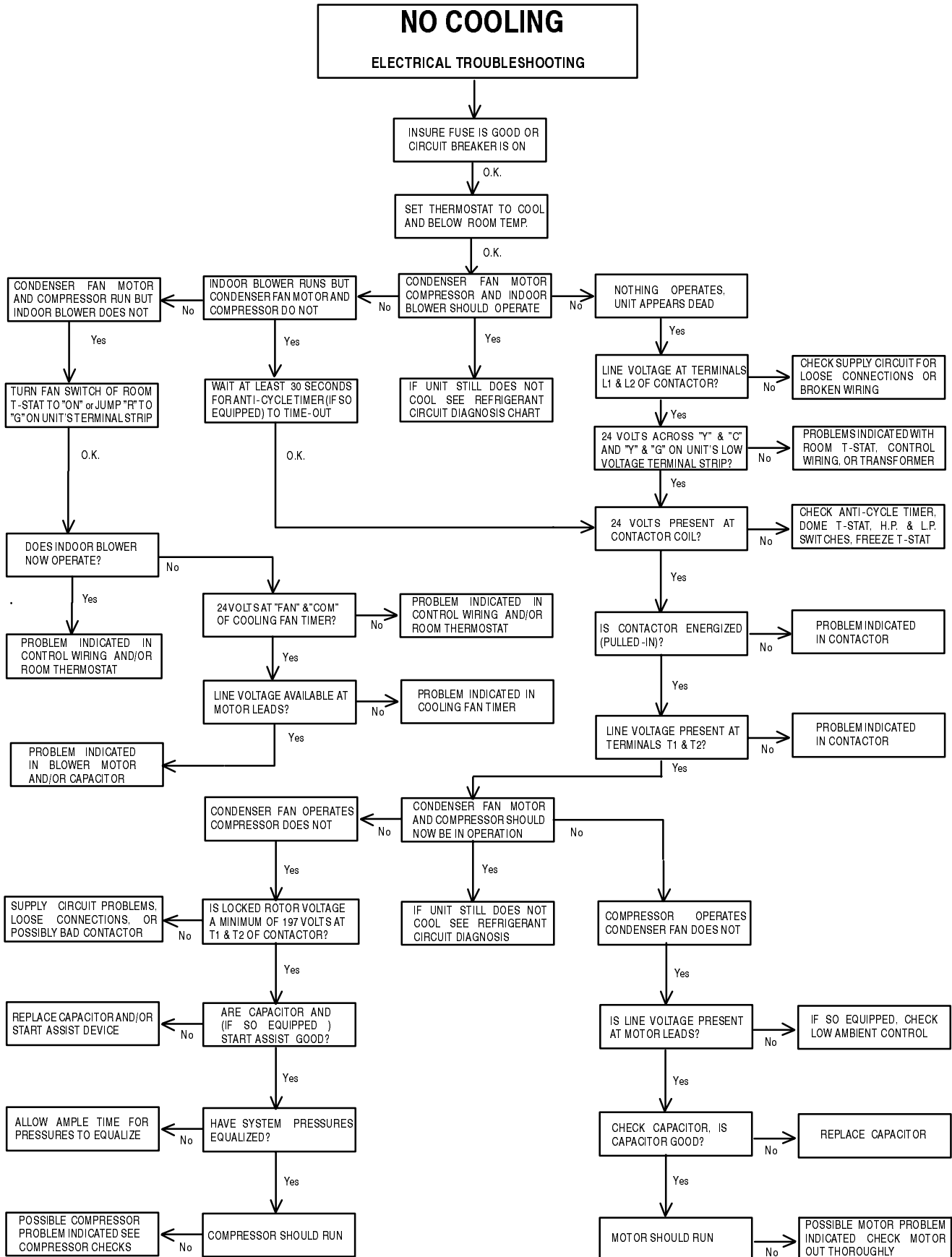

COOLING - Refrigerant Circuit Diagnosis**Symptoms Exhibited *****Condition/Solutions**

Suction Pressure	Discharge Pressure	Superheat	Sub-Cooling	
Lower Than Normal	Lower Than Normal	Lower Than Normal	Lower Than Normal	Insufficient air flow across evaporator coil. Check filter, blower speed tap selected, blower motor, wheel, and capacitor.
Lower Than Normal	Lower Than Normal	Higher Than Normal	Lower Than Normal	Insufficient refrigerant charge. Check system for leak(s). Recover refrigerant, repair leak(s), evacuate system to 500 microns, and re-charge with refrigerant.
Lower Than Normal	Lower Than Normal	Higher Than Normal	Higher Than Normal	Restriction in refrigerant circuit. Look for significant temperature difference at point of restriction. Suspect metering device first, since it is the smallest point in circuit.
Higher Than Normal	Higher Than Normal	Higher Than Normal	Higher Than Normal	Excessive loading of evaporator coil. Due to excessive air flow across evaporator or open return duct in unconditioned space. Check blower speed tap setting (too high) and return duct for leakage.
Higher Than Normal	Higher Than Normal	Lower Than Normal	Lower Than Normal	Insufficient air flow across condenser coil. Check cleanliness of condenser coil. Check condenser fan motor, blade, and capacitor.
Higher Than Normal	Higher Than Normal	Lower Than Normal	Higher Than Normal	Excessive refrigerant charge. Recover excess refrigerant from system/correct charge using Superheat method.
Higher Than Normal	Higher Than Normal	Lower Than Normal	May Be Either Lower or Higher Than Normal	Air and/or Non-Condensibles in system. Recover refrigerant from system, evacuate system to 500 microns, and weigh in charge, or charge by Superheat method.
Higher Than Normal	Lower Than Normal	Lower Than Normal	Lower Than Normal	Over feeding Metering device. Check for loose Thermostatic Expansion Valve (TXV) sensing bulb, or TXV stuck open.
Higher Than Normal	Lower Than Normal	May Be Either Lower or Higher Than Normal	May Be Either Lower or Higher Than Normal	Defective valves in compressor (I.E. runs but doesn't pump) abnormally low Amp draw and abnormally high compressor temperature may be indicated.

* "Normal" refers to Pressures, Temperatures, and/or values obtained at rated air flow under a given set of conditions and assumes that no changes have been made to factory refrigerant charge. Check the Tech Service Data Sheet for the specific model you are servicing to obtain this information. Charging by weight is accomplished using the quantity of refrigerant indicated on the Tech Service Data Sheet and/or Unit Rating Plate. Information on Superheat and Sub-Cooling is contained on page 35 of this manual.

Appendix of Helpful Information

United States Codes

Applicable Natural Gas and Propane Codes

National Fuel Gas Code, ANSI Z223.1-1992 (or current edition).

Applicable Electrical Codes

National Electrical Code

ANSI/NFPA No. 70-1990 (or current edition)

For a nominal charge, these code books can be ordered from:

American National Standards Institute
1430 Broadway
New York, NY 10018

Canadian Codes

Applicable Natural Gas and Propane Codes

Natural Gas Installation Code. CAN/CGA - B149.1-M91 (or current edition).

Propane Installation Code. CAN/CGA - B149.2-M91 (or current edition).

Applicable Electrical Codes

Canadian Electrical Code Part 1. CSA Standard C22.1 - 1990 (or current edition).

For a nominal charge, these code books can be ordered from:

Canadian Gas Association
55 Scarsdale Road
Don Mills, Ontario M3B ZR3

Canadian Standards Association
178 Rexdale Boulevard
Rexdale, Ontario M9W IR3

INDEX

A

Adjusting Heat Anticipator, 8–9
Adjusting Manifold Pressure, 6
Adjusting Pilot Flame, 20
Adjusting ST9120 "ON" and "OFF" Delays, 17
Airflow Data. *See* Technical Service Data
Anti-Cycle Timer, 30
Appendix Of Helpful Information, 141

B

Blower Assembly, Conditioned Air, 21
Blower Assembly, Removal/Replacement, 21
Blower Motor, Removal/Replacement, 21
Blower Performance. *See* Tech. Service Data
Blower Speed Selection, 22
Blower Speeds, Changing, 23
Blower, Combustion. *See* Exhaust Blower
Blower, Exhaust, 12
Burners, 7
Burners, Inspection and Cleaning, 24

C

Cam-Stat Fan Timers, 13–15
Capacitors, 12
Changing Blower Speeds, 23
Charging, Refrigerant, 34–36
Checking Capacitors, 12
Checking Compressor Windings, 32–33
Checking COOLING Fan Timers, 15
Checking HEATING Fan Timers, 14
Checking Input Rate, 5
Checking Locked Rotor Voltage, 31
Checking Manifold Pressure, 6
Checking ST9120 Fan Timer/Furnace Control, 18
Checking Temperature Rise, 7

Clocking Gas Meter, 6
Combustion Blower. *See* Exhaust Blower
Compressor Checks, 31
Compressor Control Circuit, 30–31
Compressor Winding Checks, 32–33
Compressors, 28
Contactor, Compressor, 28
Control Voltage, 5
Control Wiring, 9
Control, Low Ambient, 33
Crankcase Heaters, 29
Current Draw. *See* Tech. Service Data

D

Diagnosis, Refrigerant Circuit, 140
Discharge Thermostat, 30
Dome Thermostat. *See* Discharge Thermostat

E

Economizer Sequence of Operation, 27
Economizers, 26
Electrical Supply, 4
Exhaust Blower, 12

F

Fan Timer/Furnace Control, 15–17
Fan Timers, Cooling, 14
Fan Timers, Heating, 13
Freeze Thermostat, 31

G

Gas Supply, 5
Gas Valve/Ignition Control, 18–20

H

Heat Anticipators, 8
Heat Exchanger Inspection and Cleaning, 24
Heat Exchanger Removal/Replacement, 25
Heatcraft Fan Timers, 13–15
Heaters, Crankcase, 29
High Altitude Operation, 8
High Pressure Switch, 31
Honeywell S8600M, 20
Honeywell ST9120, 15–17
Honeywell SV9500, 18–20

I

Ignition Module, S8600M, 20
Index, Technical Service Data, 37–39
Index, Wiring Diagrams, 78–80
Introduction, 1

L

Limit Switches, 10
Locked Rotor Voltage Check, 31
Loss of Charge Protector. *See* Low Pressure Switch
Low Ambient Control, 33
Low Pressure Switch, 30
Low Voltage. *See* Control Voltage

M

Main Limit Switch, 10
Manifold Pressure, Checking and Adjusting, 6

N

No Cooling, Electrical Troubleshooting, 139
No Cooling, Refrigerant Circuit Diagnosis, 140

O

Operating Pressures. *See* Tech. Service Data

P

Performance, Cooling. *See* Technical Service Data
Pilot Flame Adjustment, 20
Pressure Switches, 11
Pressures, Operating. *See* Tech. Service Data
Protector, Compressor. *See* Discharge Thermostat
Protector, Loss of Charge. *See* Low Pressure Switch

R

Refrigerant Charging, 34–36
Refrigerant Circuit Diagnosis, 140
Roll-out Limit Switch, 11
Room Thermostats, 8

S

S8600M Ignition Module, 20
S8600M Troubleshooting Chart, 136
Sequence of Operation Chart, SV9500, 137
Sequence of Operation, Economizer, 27
ST9120 Fan Timer/Furnace Control, 15–17
ST9120 Testing Sequence, 18
Subcooling Method Of Charging, 35
Superheat Method of Charging, 35
Supply Voltage, 5
SV9500 Sequence of Operation Chart, 137
SV9500 System Operation, 19
SV9500 Troubleshooting Chart, 138
Switch, High Pressure, 31
Switch, Low Pressure, 30
Switch, Main Limit, 10
Switch, Pressure, 11
Switch, Roll-out Limit, 11
System Charging Procedures, 36

T

Technical Service Data Index, 37–39
Temperature Rise, Checking, 7
Theory of Operation, Economizers, 26–27
Theory of Operation, Furnace Section, 4
Thermostat, Crankcase Heater, 29
Thermostat, Discharge, 30
Thermostat, Dome. *See* Discharge Thermostat
Thermostat, Freeze, 31
Thermostat, Top Cap. *See* Discharge Thermostat
Thermostats, Room, 8
Timer, Anti-Cycle, 30
Troubleshooting Chart, S8600M, 136
Troubleshooting Chart, SV9500, 138

U

Unit Identification, 2

V

Voltage, Locked Rotor, 31
Voltage, Supply, 5

W

Watsco Fan Timers, 13–15
Wiring Diagram Index, 78–80