

SAMSUNG



Color Laser Printer User's Guide

CLP-610 Series

CLP-660 Series

© 2007 Samsung Electronics Co., Ltd. All rights reserved.

This user's guide is provided for information purposes only. All information included herein is subject to change without notice. Samsung Electronics is not responsible for any changes, direct or indirect damages, arising from or related to use of this user's guide.

- CLP-610ND, CLP-660N, and CLP-660ND are model names of Samsung Electronics Co., Ltd.
- Samsung and Samsung logo are trademarks of Samsung Electronics Co., Ltd.
- PCL and PCL 6 are trademarks of Hewlett-Packard company.
- Microsoft, Windows and Windows Vista are either registered trademarks or trademarks of Microsoft Corporation.
- PostScript 3 is a trademark of Adobe System, Inc.
- UFST® and MicroType™ are registered trademarks of Monotype Imaging Inc.
- TrueType, LaserWriter and Macintosh are trademarks of Apple Computer, Inc.
- All other brand or product names are trademarks of their respective companies or organizations.

contact SAMSUNG worldwide

If you have any comments or questions regarding Samsung products, contact the Samsung customer care center.

COUNTRY	CUSTOMER CARE CENTER	WEB SITE
ARGENTINE	0800-333-3733	www.samsung.com/ar
AUSTRALIA	1300 362 603	www.samsung.com
AUSTRIA	0800-SAMSUNG (726-7864)	www.samsung.com/at
BELGIUM	0032 (0)2 201 24 18	www.samsung.com/be
BRAZIL	0800-124-421 4004-0000	www.samsung.com
CANADA	1-800-SAMSUNG (726-7864)	www.samsung.com/ca
CHILE	800-SAMSUNG (726-7864)	www.samsung.com/cl
CHINA	800-810-5858 010- 6475 1880	www.samsung.com.cn
COLOMBIA	01-8000-112-112	www.samsung.com/co
COSTA RICA	0-800-507-7267	www.samsung.com/latin
CZECH REPUBLIC	844 000 844 Distributor pro Českou republiku : Samsung Zrt., česká organizační složka Vyskočilova 4, 14000 Praha 4	www.samsung.com/cz
DENMARK	70 70 19 70	www.samsung.com/dk
ECUADOR	1-800-10-7267	www.samsung.com/latin
EL SALVADOR	800-6225	www.samsung.com/latin
ESTONIA	800-7267	www.samsung.ee
KAZAHSTAN	8-10-800-500-55-500	www.samsung.kz
KYRGYZSTAN	00-800-500-55-500	
FINLAND	030-6227 515	www.samsung.com/fi
FRANCE	3260 SAMSUNG 08 25 08 65 65 (€ 0,15/min)	www.samsung.com
GERMANY	01805 - SAMSUNG (726-7864 (€ 0,14/Min)	www.samsung.com
GUATEMALA	1-800-299-0013	www.samsung.com/latin
HONDURAS	800-7919267	
HONG KONG	3698-4698	www.samsung.com/hk
HUNGARY	06-80-SAMSUNG (726-7864)	www.samsung.com
INDIA	3030 8282 1800 110011	www.samsung.com

COUNTRY	CUSTOMER CARE CENTER	WEB SITE
INDONESIA	0800-112-8888	www.samsung.com
ITALIA	800-SAMSUNG (726-7864)	www.samsung.com
JAMAICA	1-800-234-7267	www.samsung.com/latin
JAPAN	0120-327-527	www.samsung.com/jp
LATVIA	800-7267	www.samsung.com/lv
LITHUANIA	8-800-77777	www.samsung.com/lt
LUXEMBURG	0035 (0)2 261 03 710	www.samsung.com/be
MALAYSIA	1800-88-9999	www.samsung.com/my
MEXICO	01-800-SAMSUNG (726-7864)	www.samsung.com
NETHERLANDS	0900-SAMSUNG (726-7864 € 0,10/Min)	www.samsung.com/nl
NEW ZEALAND	0800SAMSUNG (726-7864)	www.samsung.com/nz
NICARAGUA	00-1800-5077267	
NORWAY	815-56 480	www.samsung.com/no
PANAMA	800-7267	www.samsung.com/latin
PHILIPPINES	1800-10-SAMSUNG (726-7864)	www.samsung.com/ph
POLAND	0 801 801 881 022-607-93-33	www.samsung.com/pl
PORTUGAL	80820-SAMSUNG (726-7864)	www.samsung.com/pt
PUERTO RICO	1-800-682-3180	www.samsung.com/latin
REP. DOMINICA	1-800-751-2676	www.samsung.com/latin
EIRE	0818 717 100	www.samsung.com/ie
RUSSIA	8-800-555-55-55	www.samsung.com
SINGAPORE	1800-SAMSUNG (726-7864)	www.samsung.com/sg
SLOVAKIA	0800-SAMSUNG (726-7864)	www.samsung.com/sk
SOUTH AFRICA	0860-SAMSUNG (726-7864)	www.samsung.com
SPAIN	902 10 11 30	www.samsung.com
SWEDEN	0771-400 200	www.samsung.com/se

COUNTRY	CUSTOMER CARE CENTER	WEB SITE
SWITZERLAND	0800-SAMSUNG (726-7864)	www.samsung.com/ch
TADJIKISTAN	8-10-800-500-55-500	
TAIWAN	0800-329-999	www.samsung.com
THAILAND	1800-29-3232 02-689-3232	www.samsung.com/th
TRINIDAD & TOBAGO	1-800-SAMSUNG (726-7864)	www.samsung.com/latin
TURKEY	444 77 11	www.samsung.com
U.A.E	800-SAMSUNG (726-7864) 8000-4726	www.samsung.com
U.K	0845 SAMSUNG (726-7864)	www.samsung.com
U.S.A.	1-800-SAMSUNG (726-7864)	www.samsung.com/us
UKRAINE	8-800-502-0000	www.samsung.com
UZBEKISTAN	8-10-800-500-55-500	www.samsung.com.uz
VENEZUELA	0-800-100-5303	www.samsung.com/latin
VIETNAM	1 800 588 889	www.samsung.com

CONTENTS

About this user's guide	i
Finding more information	i
Safety and Regulatory Information	ii
1. Introduction	
Special features	1.1
Machine overview	1.2
Front view	1.2
Rear view	1.3
Control panel overview	1.4
Understanding the Status LED	1.5
Status LED with the toner cartridge messages	1.5
Understanding the menu map	1.6
Accessing menus	1.6
Menu overview	1.6
Description on each menu	1.7
2. Software overview	
Supplied software	2.1
Printer driver features	2.1
System requirements	2.2
3. Getting Started	
Setting up the hardware	3.1
Setting up the network	3.1
Supported operating systems	3.2
Configuring network protocol via the machine	3.2
Installing the software	3.3
Printer's basic settings	3.4
Altitude Setting after Software Installation	3.4
Changing the display language	3.4
Setting job timeout	3.4
Using power saving feature	3.5
Setting the default paper size and type	3.5
Setting the default tray	3.5
Changing the font setting	3.5
Using SetIP program	3.5
4. Selecting and loading print media	
Selecting print media	4.1
Guidelines for selecting and storing print media	4.1
Specifications on print media	4.2
Media sizes supported in each mode	4.3
Guidelines for special print media	4.3
Loading paper	4.4
In the tray	4.4
In the multi-purpose tray	4.6
Setting the paper size and type	4.7

5. Basic printing

Printing a document	5.1
Canceling a print job	5.1

6. Maintenance

Printing a machine configuration report	6.1
Printing a network report	6.1
Monitoring the supplies' life	6.1
Cleaning your machine	6.1
Cleaning the outside	6.1
Cleaning the inside	6.1
Maintaining the cartridge	6.3
toner cartridge storage	6.3
Expected cartridge life	6.3
Redistributing toner	6.3
Replacing the toner cartridge	6.4
Replacing the paper transfer belt	6.6
Maintenance parts	6.7
Managing your machine from the website	6.7

7. Troubleshooting

Tips for avoiding paper jams	7.1
Clearing paper jams	7.1
In the paper feed area	7.1
In the multi-purpose tray	7.3
In the fuser unit area	7.4
In the paper exit area	7.5
In the optional tray	7.6
Understanding display messages	7.7
Solving other problems	7.10
Paper feeding problems	7.10
Printing problems	7.10
Printing quality problems	7.12
Common Windows problems	7.15
Common PostScript problems	7.15
Common Linux problems	7.16
Common Macintosh problems	7.16

8. Ordering supplies and accessories

Supplies	8.1
Accessories	8.1
How to purchase	8.1

9. Installing accessories

Precautions to take when installing accessories	9.1
Installing a memory module	9.1
Activating the added memory in the PS printer properties	9.2

10. Specifications

CLP-610 Series	10.1
CLP-660 Series	10.2

11. Glossary

Index

About this user's guide



This user's guide provides information about basic understanding of the machine as well as detailed explanation on each step during the actual usage. Both novice users and professional users can refer to this guide for installing and using the machine.

This explanation is mainly based on the Microsoft Windows operating system.

Some terms in this guide are used interchangeably, as below.



- Document is synonymous with original.
- Paper is synonymous with media, or print media.
- The model name such as CLP-6xx Series is synonymous with the machine.

The following table offers the conventions of this guide.

Convention	Description	Example
Bold	Used for texts on the display or actual prints on the machine.	Start
Note	Used to provide additional information or detailed specification of the machine function and feature.	 Note The date format may differ from country to country.
Caution	Used to give users information to protect the machine from possible mechanical damage or malfunction.	 Caution Do not touch the green underside of the toner cartridge.
Footnote	Used to provide more detailed information on certain words or a phrase.	a. pages per minute
(See page 1.1 for more information)	Used to guide users to the reference page for the additional detailed information.	(See page 1.1 for more information)

Finding more information

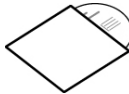
You can find information for setting up and using your machine from the following resources, either as a print-out or onscreen.

Quick Install Guide 	Provides information on setting up your machine and this requires that you follow the instructions in the guide to prepare the machine.
Online User's Guide 	Provides you with step-by-step instructions for using your machine's full features, and contains information for maintaining your machine, troubleshooting, and installing accessories. This user's guide also contains a Software section to provide you with information on how to print documents with your machine in various operating systems, and how to use the included software utilities. Note You can access the user's guide in other languages from the Manual folder on the printer software CD.
Printer Driver Help 	Provides you with help information on printer driver properties and instructions for setting up the properties for printing. To access a printer driver help screen, click Help from the printer properties dialog box.
Samsung website	If you have Internet access, you can get help, support, printer drivers, manuals, and order information from the Samsung website, www.samsungprinter.com .

Safety and Regulatory Information

Important Precautions and Safety Information

When using this machine, these basic safety precautions should always be followed to reduce risk of fire, electric shock, and injury to people:

- 1 Read and understand all instructions.
- 2 Use common sense whenever operating electrical appliances.
- 3 Follow all warnings and instructions marked on the machine and in the literature accompanying the machine.
- 4 If an operating instruction appears to conflict with safety information, heed the safety information. You may have misunderstood the operating instruction. If you cannot resolve the conflict, contact your sales or service representative for assistance.
- 5 Unplug the machine from the AC wall socket before cleaning. Do not use liquid or aerosol cleaners. Use only a damp cloth for cleaning.
- 6 Do not place the machine on an unstable cart, stand or table. It may fall, causing serious damage.
- 7 Your machine should never be placed on, near or over a radiator, heater, air conditioner or ventilation duct.
- 8 Do not allow anything to rest on the power cable. Do not locate your machine where the cords will be abused by persons walking on them.
- 9 Do not overload wall outlets and extension cords. This can diminish performance, and may result in the risk of fire or electric shock.
- 10 Do not allow pets to chew on the AC power or PC interface cords.
- 11 Never push objects of any kind into the machine through case or cabinet openings. They may touch dangerous voltage points, creating a risk of fire or shock. Never spill liquid of any kind onto or into the machine.
- 12 To reduce the risk of electric shock, do not disassemble the machine. Take it to a qualified service technician when repair work is required. Opening or removing covers may expose you to dangerous voltages or other risks. Incorrect reassembly could cause electric shock when the unit is subsequently used.
- 13 Unplug the machine from the PC and AC wall outlet, and refer servicing to qualified service personnel under the following conditions:
 - When any part of the power cord, plug, or connecting cable is damaged or frayed.
 - If liquid has been spilled into the machine.
 - If the machine has been exposed to rain or water.
 - If the machine does not operate properly after instructions have been followed.
 - If the machine has been dropped, or the cabinet appears damaged.
 - If the machine exhibits a sudden and distinct change in performance.

- 14 Adjust only those controls covered by the operating instructions. Improper adjustment of other controls may result in damage, and may require extensive work by a qualified service technician to restore the machine to normal operation.
- 15 Avoid using this machine during a lightning storm. There may be a remote risk of electric shock from lightning. If possible, unplug the AC power for the duration of the lightning storm.
- 16 If you continuously print multiple pages, the surface of the output tray may become hot. Be careful not to touch the surface, and keep children away from the surface.
- 17 The Power cord supplied with your machine should be used for safe operation. If you are using a cord which is longer than 2 m with 110 V machine, then it should be 16 AWG¹ or bigger.
- 18 SAVE THESE INSTRUCTIONS.

Environmental and Safety Consideration

Laser Safety Statement

The printer is certified in the U.S. to conform to the requirements of DHHS 21 CFR, chapter 1 Subchapter J for Class I(1) laser products, and elsewhere, is certified as a Class I laser product conforming to the requirements of IEC 825.

Class I laser products are not considered to be hazardous. The laser system and printer are designed so there is never any human access to laser radiation above a Class I level during normal operation, user maintenance, or prescribed service condition.

Warning

Never operate or service the printer with the protective cover removed from Laser/Scanner assembly. The reflected beam, although invisible, can damage your eyes.

¹ AWG: American Wire Gauge

When using this product, these basic safety precautions should always be followed to reduce risk of fire, electric shock, and injury to persons:



Ozone Safety



During normal operation, this machine produces ozone. The ozone produced does not present a hazard to the operator. However, it is advisable that the machine be operated in a well ventilated area.

If you need additional information about ozone, contact your nearest Samsung dealer.

Power Saver



This printer contains advanced energy conservation technology that reduces power consumption when it is not in active use.

When the printer does not receive data for an extended period of time, power consumption is automatically lowered.

ENERGY STAR and the ENERGY STAR mark are registered U.S. marks.

For more information on the ENERGY STAR program see <http://www.energystar.gov>

Recycling



Recycle or dispose of packaging materials for this product in an environmentally responsible manner.

Correct Disposal of This Product (Waste Electrical & Electronic Equipment)

(Applicable in the European Union and other European countries with separate collection systems)



This marking shown on the product or its literature, indicates that it should not be disposed with other household wastes at the end of its working life. To prevent possible harm to the environment or human health from uncontrolled waste disposal, separate this from other types of wastes and recycle it responsibly to promote the sustainable reuse of material resources.

Household users should contact either the retailer where they purchased this product, or their local government office, for details of where and how they can take this item for environmentally safe recycling.

Business users should contact their supplier and check the terms and conditions of the purchase contract. This product should not be mixed with other commercial wastes for disposal.

Radio Frequency Emissions

FCC Regulations

This device complies with Part 15 of the FCC Rules. Operation is subject to the following two conditions:

- This device may not cause harmful interference, and
- This device must accept any interference received, including interference that may cause undesired operation.

This device has been tested and found to comply with the limits for a Class B digital device, pursuant to Part 15 of the FCC rules. These limits are designed to provide reasonable protection against harmful interference in a residential installation. This equipment generates, uses and can radiate radio frequency energy and, if not installed and used in accordance with the instructions, may cause harmful interference to radio communications. However, there is no guarantee that interference will not occur in a particular installation. If this equipment does cause harmful interference to radio or television reception, which can be determined by turning the equipment off and on, the user is encouraged to try to correct the interference by one or more of the following measures:

- Reorient or relocate the receiving antenna.
- Increase the separation between the equipment and receiver.
- Connect the equipment into an outlet on a circuit different from that to which the receiver is connected.
- Consult the dealer or an experienced radio/TV technician for help.

Caution:

Changes or modifications not expressly approved by the manufacturer responsible for compliance could void the user's authority to operate the equipment.

Canadian Radio Interference Regulations

This digital apparatus does not exceed the Class B limits for radio noise emissions from digital apparatus as set out in the interference-causing equipment standard entitled "Digital Apparatus", ICES-003 of the Industry and Science Canada.

Cet appareil numérique respecte les limites de bruits radioélectriques applicables aux appareils numériques de Classe B prescrites dans la norme sur le matériel brouilleur: "Appareils Numériques", ICES-003 édictée par l'Industrie et Sciences Canada.

Declaration of Conformity (European Countries)

Approvals and Certifications



The CE marking applied to this product symbolizes Samsung Electronics Co., Ltd. Declaration of Conformity with the following applicable 93/68/EEC Directives of the European Union as of the dates indicated:

January 1, 1995: Council Directive 73/23/EEC Approximation of the laws of the member states related to low voltage equipment.

January 1, 1996: Council Directive 89/336/EEC (92/31/EEC), approximation of the laws of the Member States related to electromagnetic compatibility.

March 9, 1999: Council Directive 1999/5/EC on radio equipment and telecommunications terminal equipment and the mutual recognition of their conformity.

A full declaration, defining the relevant Directives and referenced standards can be obtained from your Samsung Electronics Co., Ltd. representative.

Replacing the Fitted Plug (for UK Only)

Important

The mains lead for this machine is fitted with a standard (BS 1363) 13 amp plug and has a 13 amp fuse. When you change or examine the fuse, you must re-fit the correct 13 amp fuse. You then need to replace the fuse cover. If you have lost the fuse cover, do not use the plug until you have another fuse cover.

Please contact the people from you purchased the machine.

The 13 amp plug is the most widely used type in the UK and should be suitable. However, some buildings (mainly old ones) do not have normal 13 amp plug sockets. You need to buy a suitable plug adaptor. Do not remove the moulded plug.

Warning

If you cut off the moulded plug, get rid of it straight away.

You cannot rewire the plug and you may receive an electric shock if you plug it into a socket.

Important warning: You must earth this machine.

The wires in the mains lead have the following color code:

- Green and Yellow: Earth
- Blue: Neutral
- Brown: Live

If the wires in the mains lead do not match the colors marked in your plug, do the following:

You must connect the green and yellow wire to the pin marked by the letter "E" or by the safety 'Earth symbol' or colored green and yellow or green.

You must connect the blue wire to the pin which is marked with the letter "N" or colored black.

You must connect the brown wire to the pin which is marked with the letter "L" or colored red.

You must have a 13 amp fuse in the plug, adaptor, or at the distribution board.

OpenSSL License

Copyright (c) 1998-2001 The OpenSSL Project. All rights reserved.

Redistribution and use in source and binary forms, with or without modification, are permitted provided that the following conditions are met:

Redistributions of source code must retain the above copyright notice, this list of conditions and the following disclaimer.

Redistributions in binary form must reproduce the above copyright notice, this list of conditions and the following disclaimer in the documentation and/or other materials provided with the distribution.

All advertising materials mentioning features or use of this software must display the following acknowledgment: "This product includes software developed by the OpenSSL Project for use in the OpenSSL Toolkit. (<http://www.openssl.org/>)"

The names "OpenSSL Toolkit" and "OpenSSL Project" must not be used to endorse or promote products derived from this software without prior written permission. For written permission, please contact openssl-core@openssl.org.

Products derived from this software may not be called "OpenSSL" nor may "OpenSSL" appear in their names without prior written permission of the OpenSSL Project.

Redistributions of any form whatsoever must retain the following acknowledgment: "This product includes software developed by the OpenSSL Project for use in the OpenSSL Toolkit (<http://www.openssl.org/>)"

THIS SOFTWARE IS PROVIDED BY THE OpenSSL PROJECT ``AS IS'' AND ANY EXPRESSED OR IMPLIED WARRANTIES, INCLUDING, BUT NOT LIMITED TO, THE IMPLIED WARRANTIES OF MERCHANTABILITY AND FITNESS FOR A PARTICULAR PURPOSE ARE DISCLAIMED. IN NO EVENT SHALL THE OpenSSL PROJECT OR ITS CONTRIBUTORS BE LIABLE FOR ANY DIRECT, INDIRECT, INCIDENTAL, SPECIAL, EXEMPLARY, OR CONSEQUENTIAL DAMAGES (INCLUDING, BUT NOT LIMITED TO, PROCUREMENT OF SUBSTITUTE GOODS OR SERVICES; LOSS OF USE, DATA, OR PROFITS; OR BUSINESS INTERRUPTION) HOWEVER CAUSED AND ON ANY THEORY OF LIABILITY, WHETHER IN CONTRACT, STRICT LIABILITY, OR TORT (INCLUDING NEGLIGENCE OR OTHERWISE) ARISING IN ANY WAY OUT OF THE USE OF THIS SOFTWARE, EVEN IF ADVISED OF THE POSSIBILITY OF SUCH DAMAGE.

This product includes cryptographic software written by Eric Young(ey@cryptsoft.com). This product includes software written by Tim Hudson (tjh@cryptsoft.com).

Original SSLeay License

Copyright (C) 1995-1998 Eric Young (eay@cryptsoft.com) All rights reserved.

This package is an SSL implementation written by Eric Young (eay@cryptsoft.com). The implementation was written so as to conform with Netscapes SSL.

This library is free for commercial and non-commercial use as long as the following conditions are aheared to. The following conditions apply to all code found in this distribution, be it the RC4, RSA, lhash, DES, etc., code; not just the SSL code. The SSL documentation included with this distribution is covered by the same copyright terms except that the holder is Tim Hudson (tjh@cryptsoft.com). Copyright remains Eric Young's, and as such any Copyright notices in the code are not to be removed. If this package is used in a product, Eric Young should be given attribution as the author of the parts of the library used. This can be in the form of a textual message at program startup or in documentation (online or textual) provided with the package.

Redistribution and use in source and binary forms, with or without modification, are permitted provided that the following conditions are met:

Redistributions of source code must retain the copyright notice, this list of conditions and the following disclaimer.

Redistributions in binary form must reproduce the above copyright notice, this list of conditions and the following disclaimer in the documentation and/or other materials provided with the distribution.

All advertising materials mentioning features or use of this software must display the following acknowledgement: "This product includes cryptographic software written by Eric Young (eay@cryptsoft.com)" The word 'cryptographic' can be left out if the rouines from the library being used are not cryptographic related:-).

If you include any Windows specific code (or a derivative thereof) from the apps directory (application code) you must include an acknowledgement: "This product includes software written by Tim Hudson (tjh@cryptsoft.com)"

THIS SOFTWARE IS PROVIDED BY ERIC YOUNG ``AS IS'' AND ANY EXPRESS OR IMPLIED WARRANTIES, INCLUDING, BUT NOT LIMITED TO, THE IMPLIED WARRANTIES OF MERCHANTABILITY AND FITNESS FOR A PARTICULAR PURPOSE ARE DISCLAIMED. IN NO EVENT SHALL THE AUTHOR OR CONTRIBUTORS BE LIABLE FOR ANY DIRECT, INDIRECT, INCIDENTAL, SPECIAL, EXEMPLARY, OR CONSEQUENTIAL DAMAGES (INCLUDING, BUT NOT LIMITED TO, PROCUREMENT OF SUBSTITUTE GOODS OR SERVICES; LOSS OF USE, DATA, OR PROFITS; OR BUSINESS INTERRUPTION) HOWEVER CAUSED AND ON ANY THEORY OF LIABILITY, WHETHER IN CONTRACT, STRICT LIABILITY, OR TORT (INCLUDING NEGLIGENCE OR OTHERWISE) ARISING IN ANY WAY OUT OF THE USE OF THIS SOFTWARE, EVEN IF ADVISED OF THE POSSIBILITY OF SUCH DAMAGE.

The licence and distribution terms for any publically available version or derivative of this code cannot be changed. i.e. this code cannot simply be copied and put under another distribution licence [including the GNU Public Licence.]



ELECTRONICS

Declaration of Conformity

For the following product:
Color Laser Printer

Manufactured at:
of Samsung Electronics Co., Ltd.
#259, Gongdan-Dong, Gumi-City, Gyeongsangbuk-Do, 730-030 Korea
(Factory name, address)

We hereby declare, that the product above is in compliance with the essential requirements of the Low Voltage Directive (2006/95/EC) and EMC Directive (2004/108/EC) by application of:

EN 60950-1:2001+A11:2004
EN 55022:1998 + A1:2000 + A2:2003
EN 55024:1998 + A1:2001 + A2:2003
EN 61000-3-2:2000
EN 61000-3-3:1995 + A1:2001

The Technical documentation is kept at the below Manufacturer's address.

Manufacturer

Samsung Electronics Co., Ltd.
#259, Gongdan-Dong, Gumi-City
Gyungbuk, Korea 730-030

July 24, 2007

Whan-Soon Yim / S. Manager

Representative in the EU:

Samsung Electronics Euro QA Lab.
Blackbushe Business Park
Saxony Way, Yateley, Hampshire
GU46 6GG, UK

July 24, 2007
(Place and date of issue)

Yong Sang Park / S. Manager

1 Introduction

Thank you for purchasing this Samsung color printer.

This chapter includes:

- **Special features**
- **Machine overview**
- **Control panel overview**
- **Understanding the Status LED**
- **Understanding the menu map**



Note

Some features are optional. Check the specifications sections. (See "Specifications" on page 10.1.)

Special features

Your new machine is equipped with special features.

Print with excellent quality and speed



- You can print in a full range of colors using cyan, magenta, yellow, and black.
- You can print up to 2400 x 600 dpi effective output. See Software section.
- Your machine prints A4-sized paper at up to 20 ppm^a (CLP-610 series), 24 ppm (CLP-660 series) and letter-sized paper at up to 21 ppm (CLP-610 series), 25 ppm (CLP-660 series).

Handle different paper options with flexibility



- The **multi-purpose tray** supports letterhead, envelopes, labels, custom-sized media, postcards, and heavy paper. The **multi-purpose tray** holds up to 100 sheets of plain paper for the CLP-610ND and CLP-660 series.
- The **250-sheet tray 1** and **500-sheet optional tray** support plain paper in various sizes.

Create professional documents

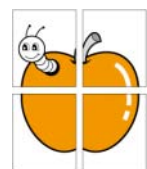

- Print **Watermarks**. You can customize your documents with words, such as "Confidential". See Software section.
- Print **Posters**. The text and pictures of each page of your document are magnified and printed across the sheet of paper and can then be taped together to form a poster. See Software section.
- You can use preprinted forms and letterhead with plain paper. See Software section.

Save time and money



- To save paper, you can print multiple pages on one single sheet of paper.
- This machine automatically **conserves electricity** by substantially reducing power consumption when not in use.
- To save paper, you can print on both sides of the paper (double-sided printing). This feature is supported depending on the models. See Software section.

Expand your machine's capacity

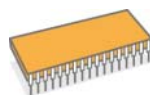

- Your machine has an extra memory slot to expand their memory. (Page 8.1)
- Zoran IPS Emulation* compatible with **PostScript 3 Emulation*** (PS) enables PS printing.

* Zoran IPS Emulation compatible with PostScript 3



© Copyright 1995-2005, Zoran Corporation. All rights reserved. Zoran, the Zoran logo, IPS/PS3, and OneImage are trademarks of Zoran Corporation.

* 136 PS3 fonts
Contains UFST and MicroType from Monotype Imaging Inc.

Print in various environments



- You can print with **Windows 2000/XP/2003/Vista** as well as **Linux** and **Macintosh** systems.
- Your machine is equipped with a **USB** interface and a **network** interface.

a. pages per minute

b. images per minute

Machine overview

These are the main components of your machine.

Front view

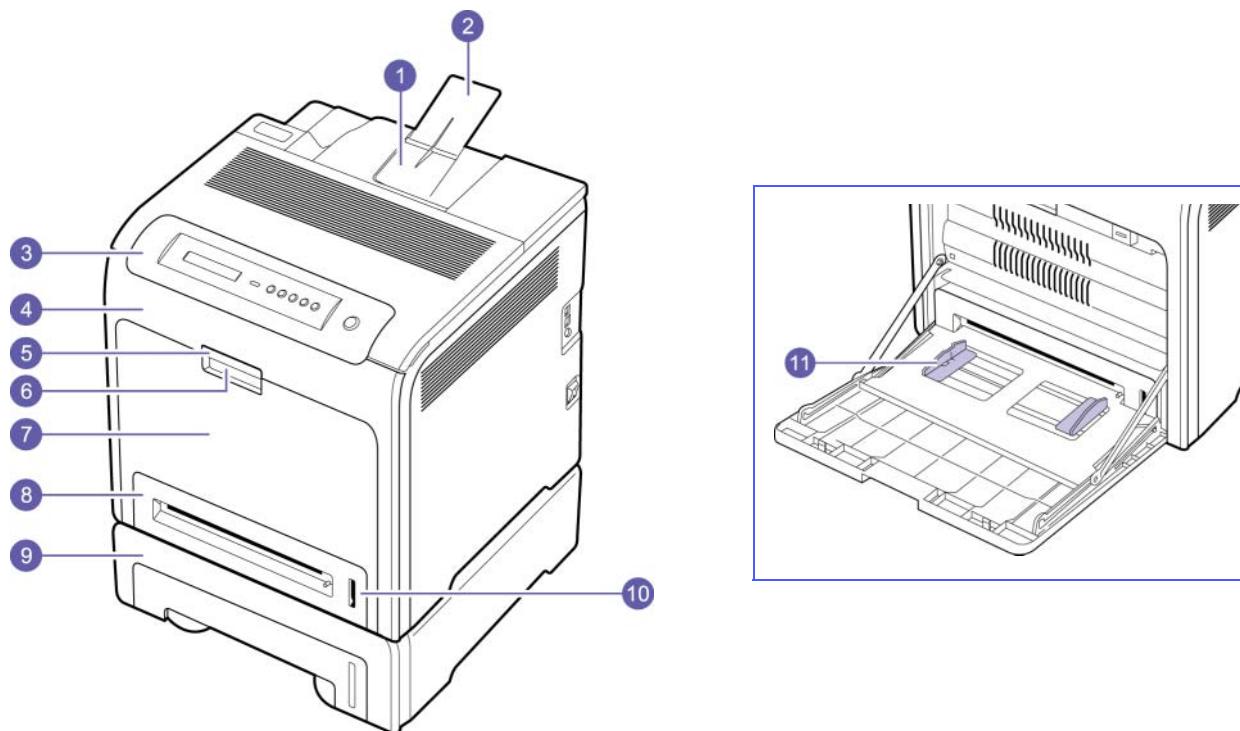

- The figure above shows your machine with the available accessories. (See page 8.1 for more information)
- The symbol * denotes an optional device.

1	output tray	7	multi-purpose tray
2	output support	8	tray 1
3	control panel	9	optional tray*
4	front cover	10	paper level indicator
5	front cover handle	11	multi-purpose tray paper width guides
6	multi-purpose tray handle		



Note

- All illustrations on this user's guide may differ from your machine depending on its options or models.
- The surface of the output tray may become hot if you print a large number of pages at once. Make sure that you do not touch the surface, and do not allow children near it.

Rear view

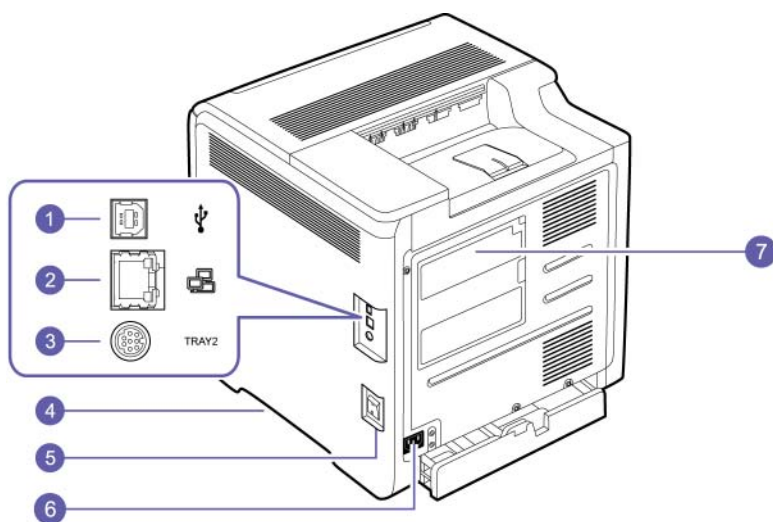

- The figure above shows your machine with the available accessories.
- The symbol * denotes an optional device.

1	USB port	5	power switch
2	network port	6	power receptacle
3	15-pin Optional tray connection*	7	control board cover (Memory module, see page 9.1 for more information)
4	handle (Use these handles to move your machine.)		

Control panel overview

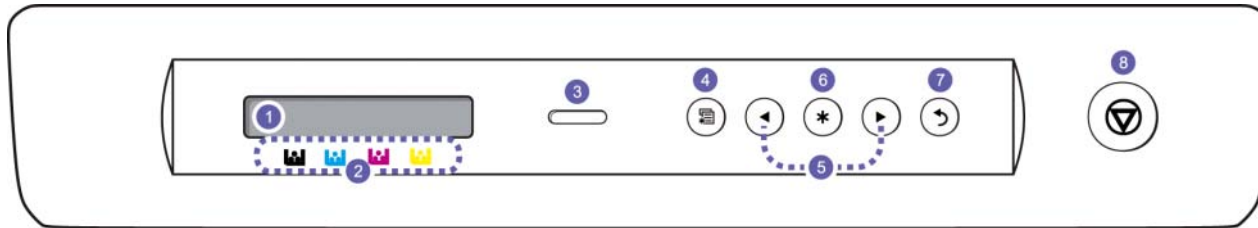

1	Display: Shows the current status and prompts during an operation.	5	Left/right arrow: Navigates available values by moving to the next or previous options.
2	Toner colors: The toner colors shown below the LCD display work together with the display messages. See Status LED with the toner cartridge messages on page 1.5.	6	OK: Confirms the selection on the display.
3	Status: Shows the status of your machine. (See "Understanding the Status LED" on page 1.5 for more information.)	7	Back: Sends you back to the upper menu level.
4	Menu: Enters Menu mode and scrolls through the available menus. (See "Understanding the Status LED" on page 1.5 for more information.)	8	Stop: Stops an operation at any time.

Understanding the Status LED

The color of the **Status** LED indicates the machine's current status.

Status		Description
Off		<ul style="list-style-type: none">The machine is powered off.
Green	Blinking	<ul style="list-style-type: none">When the green LED slowly blinks, the machine is receiving data from the computer.When the green LED blinks rapidly, the machine is printing data.
	On	<ul style="list-style-type: none">The machine is powered on and can be used.The machine is in power save mode. When data is received, it switches to the ready mode automatically.
Red	Blinking	<ul style="list-style-type: none">A minor error has occurred and the machine is waiting for the error to be cleared. Check the display message, and solve the problem referring to "Understanding display messages" on page 7.7.The toner cartridge is low. Order a new toner cartridge, see "Ordering supplies and accessories" on page 8.1. You can temporarily improve print quality by redistributing the toner. See "Replacing the toner cartridge" on page 6.4.
	On	<ul style="list-style-type: none">A problem has occurred such as a paper jam, opened cover or no paper in the tray, so that the machine can not continue the job. Check the message on the display, and refer to Understanding display messages on page 7.7 to solve the problem.The toner cartridge is empty, exhausted, or needs to be changed. See "Understanding display messages" on page 7.7.



Note

Always check the message on the display to solve the problem. The instruction in the Troubleshooting section will guide you to operate the machine properly. See page 7.1 for more information.

Status LED with the toner cartridge messages

The status of toner cartridges is indicated by the status LED and the LCD display. If the toner cartridge is low or needs to be changed, the status LED turns red and the display shows the message. However the arrow mark (or marks) shows which color toner is of concern or may be installed with a new cartridge.

Example:



The above example shows the magenta toner cartridge status indicated by the arrow. Check the message to find out what the problem is and how to solve it. See page 7.7 to browse the detailed information on error messages.

Understanding the menu map

The control panel provides access to various menus to set up the machine or to use the machine's functions. Refer to the following diagram.

Accessing menus

The next steps show how to print the menu map of this machine, and they are the general way to select menus and configure your machine.

- 1 Make sure your machine is properly connected with all the necessary cables, and turn on the machine.
- 2 Press **Menu** on the control panel, until you see the menu (ex. Information) you want on the bottom line of the display.
- 3 Press **OK** to access the menu.
- 4 Press left/right arrow until the menu item (ex. Menu Map) you want displays on the bottom line.
- 5 Press the **OK** button to confirm the selected item.



Note

If the menu item has sub menus, repeat steps 4 and 5.

- 6 Press left/right arrow until the menu item (ex. Print?) you want displays on the bottom line.
- 7 Press **OK** to process your selection, save your input or selection.
An asterisk (*) appears next to the selection on the display, indicating that it is now the default.
- 8 To exit the menu, press **Back** repeatedly, or **Stop**.



Note

- If no key is pressed within one minute, the machine automatically returns to ready mode.
- The print settings made from the printer driver on a connected computer override the settings on the control panel.

Menu overview

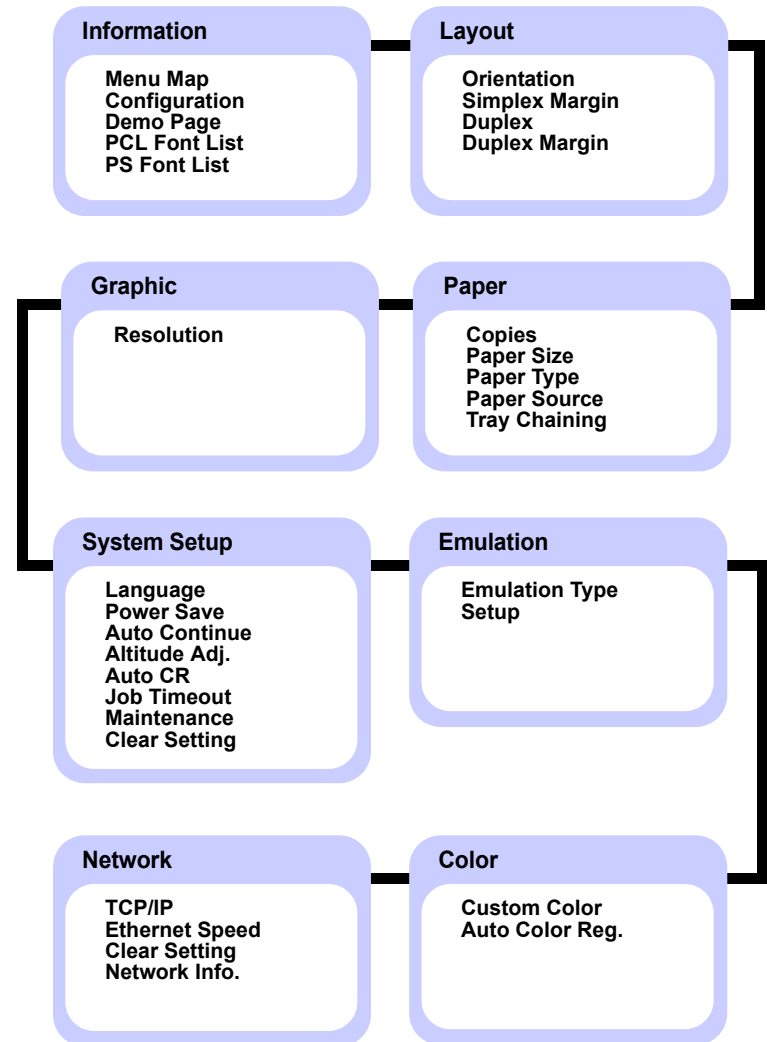

Description on each menu

The following tables provide the information on each menu.





Note



The symbol * denotes an optional menu depending on machines.

Information

Menu	Description
Menu Map	You can print the menu map which shows the layout and current settings of this machine.
Configuration	You can print the machine's current configuration.
Demo Page	The demo page is a sample of the machine's imaging capabilities.
PCL Font List*	You can print the PCL font list.
PS Font List*	You can print the PS font list.

Layout

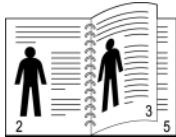
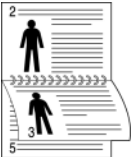
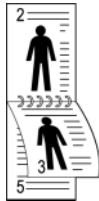
Menu	Description
Orientation	<p>This menu allows you to select the direction in which information is printed on a page. Landscape and Portrait are selectable.</p> <div style="display: flex; justify-content: space-around; align-items: center;"> <div style="text-align: center;">  <p>Portrait</p> </div> <div style="text-align: center;">  <p>Landscape</p> </div> </div>
Simplex Margin	<p>Set the margin of print materials for one-sided printing. You can increase or decrease the value in 1 mm (or inch) increments.</p> <ul style="list-style-type: none"> • Top Margin: Set the top margin. • Left Margin: Set the left margin.

Menu	Description
Duplex*	<p>To print on both sides of paper, choose the binding edge as follows.</p> <ul style="list-style-type: none"> • Long Edge: Flip on the long edge. • Short Edge: Flip on the short edge. <p>Select Off to print on one side of the paper.</p> <div style="display: flex; justify-content: space-around; align-items: center;"> <div style="text-align: center;">  <p>Long Edge in the Portrait orientation</p> </div> <div style="text-align: center;">  <p>Long Edge in the Landscape orientation</p> </div> </div> <div style="display: flex; justify-content: space-around; align-items: center; margin-top: 20px;"> <div style="text-align: center;">  <p>Short Edge in the Portrait orientation</p> </div> <div style="text-align: center;">  <p>Short Edge in the Landscape orientation</p> </div> </div>
Duplex Margin*	<p>In this menu, you can set the margins for double-sided printing. You can increase or decrease the value in 0.1 mm increments.</p> <ul style="list-style-type: none"> • Top Margin: Set the top margin. • Left Margin: Set the left margin. • Short Binding: Set the bottom margin of the back of the page for short binding. • Long Binding: Set the right margin of the back of the page for long binding.

Paper

Menu	Description
Copies	You can select the maximum amount of copies.
Paper Size	You can select the default paper size. (See page 3.5 for more information)
Paper Type	You can select the default paper type for the print media.

Menu	Description
Paper Source	You can select the tray to process the print job. If you select Auto , your machine supplies the paper from the multi-purpose tray first, then the tray 1, and tray 2 for the last. So if any tray is empty, then the machine tries to search the paper from the next available tray. (See page 3.5 for more information)
Tray Chaining	When you select any other value except Auto from Paper Source and the selected tray is empty, you can set the machine to automatically print from other trays. If this menu item is set to Off , the machine does not print until you insert paper into the specified tray.

Graphic

Menu	Description
Resolution	You can select the default resolution. If the resolution is high, the clarity of the printouts is sharper, but the print time may take longer. <ul style="list-style-type: none"> • Draft: If the printer language is PCL and your print jobs are text, select this option for the best speed and printing quality. This option is available only with PCL driver. • Normal: If your print jobs are mostly text, select this option for the highest quality output. • Best: select this option when your job contains bitmapped images, such as scanned photos or certain business graphics, that will benefit from enhanced line screening.

System Setup

Menu	Description
Language	The language setting for the display on the control panel determines the language of the text that appears on the control panel display and for printing information. (See page 3.4 for more information)
Power Save	When the machine does not receive data for an extended period of time, power consumption is automatically lowered. You can set how long the machine waits before going to power save. (See page 3.5 for more information)

Menu	Description
Auto Continue	This item determines whether or not the machine continues printing when it detects paper that is not matched to your paper setting. <ul style="list-style-type: none"> • Off: If a paper mismatch occurs, the message remains on the display and the machine remains off-line until you insert the correct paper. • On: If the paper is mismatched, an error message displays. The machine goes off-line for 30 seconds then automatically clears the message and continues printing.
Altitude Adj.	You can optimize the print quality according to your altitude.
Auto CR	This option allows you to append the required carriage return to each line feed, which is useful to the Unix user or DOS user. Refer to the following samples: <div style="display: flex; justify-content: space-around; align-items: center; margin-top: 10px;"> <div style="border: 1px solid black; padding: 5px; text-align: center;"> AA BB CC LF </div> <div style="border: 1px solid black; padding: 5px; text-align: center;"> AA BB CC LF+CR </div> </div>
Job Timeout	You can set the amount of time a single print job is active before it must print. The machine handles incoming data as a single job, if it comes in within the specified time. When an error occurs while processing data from the computer and the data flow stops, the machine waits the specified amount of time and then cancels printing if data flow does not resume. (See page 3.4 for more information)
Maintenance	This menu allows you to maintain consumables within the machine and check supplies' life. You can clean fuser components. (See page 6.1 for more information)
Clear Setting	This menu item allows you to restore the printer's factory default settings.

Emulation

Menu	Description
Emulation Type	You can select the machine language. If the languages from the computer and the machine are different, the printing quality can not be confirmed. It is recommended to set this menu to Auto to switch the proper language.

Menu	Description
Setup	<p>PCL</p> <p>This menu sets the PCL emulation configuration. You can set the font type, symbol type, lines per page, and font size.</p> <ul style="list-style-type: none"> • Typeface: You can select the standard font to be used in PCL emulation. PCL1~PCL7's interval between letters is fixed, and PCL8~PCL45's interval is proportional to the font type and font size. You can adjust the font size of PCL1~PCL7 using the Pitch item, and PCL8~PCL45 can do using Point Size item. PCL8~PCL56's interval and font size are fixed. • Symbol: This item selects the symbol set to be used in PCL emulation. The symbol is the group of numbers, marks, and special signs being used when printing letters. Depending on the Typeface setting, available symbol sets vary. • Point Size: When you select one between PCL8 and PCL45 from the Typeface menu, you can determine the font size by setting the height of the characters in the font. • Courier: This item lets you select the version of Courier font to use. • Pitch: When you select one between PCL1 and PCL7 from the Typeface menu, you can determine the font size by setting the number of characters that will print in one horizontal inch of type. The default value, 10 is the best size. • Lines: This item allows you to set vertical spacing from 5 to 128 lines for the default paper size. The default number of lines may differ according to the paper size and printing orientation. <p>PostScript</p> <p>This menu provides you with the Print PS Error menu item. You can select whether or not your printer prints an error list when a PS error occurs. Select On to print PS 3 emulation errors. If an error occurs, the job stops processing, the error message prints, and the printer flushes the job. If this menu is set to Off, the job is flushed without an indication of the error.</p>

Color

Menu	Description
Custom Color	<p>This menu allows you to adjust contrast, color by color.</p> <ul style="list-style-type: none"> • Default: Optimizes colors automatically. • Manual Adjust: Allows you to manually adjust the color contrast for each cartridge. <p>It is recommended to use the Default setting for best color quality.</p>
Auto Color Reg.	<p>The machine can automatically adjust the engine color alignment for text or graphics.</p> <p> Note If you have moved the machine, it is strongly recommended to operate this menu manually.</p>

Network

Menu	Description
TCP/IP	<p>If you are using the TCP/IP protocol for networking, select this menu.</p> <ul style="list-style-type: none"> • DHCP: The DHCP server allots an IP address to you automatically. • BOOTP: The BOOTP server allots an IP address to you automatically. • Static: You can enter an IP address, subnetmask, and gateway manually.
Ethernet Speed	<p>This item allows you to select the communication speed for ethernet connection.</p>
Clear Setting	<p>You can clear the network setting you have set.</p>
Network Info.	<p>You can print the network configuration report.</p>

2 Software overview

This chapter gives you an overview of the software that comes with your machine. Further details on how to use the software are explained in the Software section.

This chapter includes:

- **Supplied software**
- **Printer driver features**
- **System requirements**

Supplied software

You must install the machine software using the supplied CD's after you have set up your machine and connected it to your computer.

Each CD provides you with the following software:

CD	Contents	
Printer software CD	Windows	<ul style="list-style-type: none"> • Printer driver: Use this driver to take full advantage of your machine's features. • PostScript Printer Description (PPD) file^a: Use the PostScript driver to print documents with complex fonts and graphics in the PS language. • Smart Panel: This program allows you to monitor the machine's status and alerts you when an error occurs during printing. • User's Guide in PDF • SetIP: Use this program to set your machine's TCP/IP addresses. • Adobe Acrobat Reader: The application which you can browse the user's guide.
	Linux	<ul style="list-style-type: none"> • PostScript Printer Description^a: Use this driver to run your machine from a Linux computer and print documents.
	Macintosh	<ul style="list-style-type: none"> • Postscript Printer Description (PPD) file^a: Use this file to run your machine from a Macintosh computer and print documents. • Smart Panel: This program allows you to monitor the machine's status and alerts you when an error occurs during printing.

a. This feature is available with the CLP-660 series only.

Printer driver features

Your printer drivers support the following standard features:

- Paper source selection
- Paper size, orientation and media type
- Number of copies



Note

The symbol * denotes an optional menu depending on machines.

In addition, you can use various special printing features. The following table shows a general overview of features supported by your printer drivers:

Printer driver (CLP-610 Series)

Feature	Windows	Linux	Macintosh
Printer Languages	SPL, PCL5c, PCL6	SPL	SPL
Color mode	O	O	O
Machine quality option	O	O	O
Poster printing	O	X	X
Multiple pages per sheet (N-up)	O	O (2, 4)	O (2, 4, 6, 9, 16)
Fit to page printing	O	X	X
Scale printing	O	X	O
Different source for first page	O	X	O
Watermark	O	X	X
Overlay	O	X	X
Duplex	O	O	O



Note

If you want to change the printer language, go to printer properties, and change the printer language in Printer tab.

Printer driver (CLP-660 Series)

Feature	Windows	Linux	Macintosh
Printer Languages	SPL, PCL5c, PCL6 (PS)	PS	PS
Color mode	○	○	○
Machine quality option	○	○	○
Poster printing	○ (X)	X	X
Multiple pages per sheet (N-up)	○	○ (2, 4)	○ (2, 4, 6, 9, 16)
Fit to page printing	○	X	X
Scale printing	○	X	○
Different source for first page	○ (X)	X	○
Watermark	○ (X)	X	X
Overlay	○ (X)	X	X
Duplex *	○	○	○



Note

If you want to change the printer language, go to printer properties, and change the printer language in Printer tab.

System requirements

Before you begin, ensure that your system meets the following requirements:

Windows

Your machine supports the following Windows operating systems.

OS	Requirement (recommended)		
	CPU	RAM	free HDD space
Windows 2000	Pentium II 400 MHz (Pentium III 933 MHz)	64 MB (128 MB)	300 MB
Windows XP	Pentium III 933 MHz (Pentium IV 1 GHz)	128 MB (256 MB)	1.5 GB
Windows 2003 Server	Pentium III 933 MHz (Pentium IV 1 GHz)	128 MB (512 MB)	1.25 GB to 2 GB

OS	Requirement (recommended)		
	CPU	RAM	free HDD space
Windows Vista	Pentium IV 3 GHz	512 MB (1024 MB)	15 GB



Note

- Internet Explorer 5.0 or higher is the minimum requirement for all Windows operating systems.
- Users who have an administrator right can install the software.

Linux

Item	Requirements
Operating system	<ul style="list-style-type: none"> Red Hat 8 ~ 9 Fedora Core 1 ~ 4 Mandrake 9.2 ~ 10.1 SuSE 8.2 ~ 9.2
CPU	Pentium IV 1 GHz or higher
RAM	256 MB or higher
free HDD space	1 GB or higher
Software	<ul style="list-style-type: none"> Linux Kernel 2.4 or higher Glibc 2.2 or higher CUPS

Macintosh

Item	Requirements
Operating system	Macintosh 10.3 ~ 10.5 (CLP-610 series) Macintosh 10.1 ~ 10.5 (CLP-660 series)
CPU	Intel processor Power PC G4 /G5
RAM	512 MB for an Intel-based Mac, 128 MB for a Power PC based Mac
free HDD space	1 GB
Connection	USB interface or Network interface

3 Getting Started

This chapter gives you step-by-step instructions for setting up the machine.

This chapter includes:

- **Setting up the hardware**
- **Setting up the network**
- **Installing the software**
- **Printer's basic settings**

Setting up the hardware

This section shows the steps to set up the hardware which is explained in the Quick Install Guide. Make sure you read Quick Install Guide and complete following steps.

1 Select a stable location.

Select a level, stable place with adequate space for air circulation. Allow extra space to open covers and trays.

The area should be well-ventilated and away from direct sunlight or sources of heat, cold, and humidity. Do not set the machine close to the edge of your desk or table.

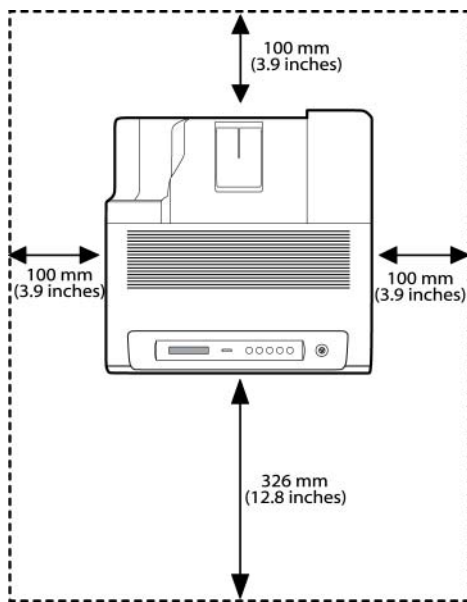

Printing is suitable for altitudes under 1,000 m (3,281 ft). Refer to the altitude setting to optimize your printing. See page 3.4 for more information.

Place the machine on a flat and stable surface, not letting it tilt more than 2 mm (0.08 inches). Otherwise, it may affect the print quality.

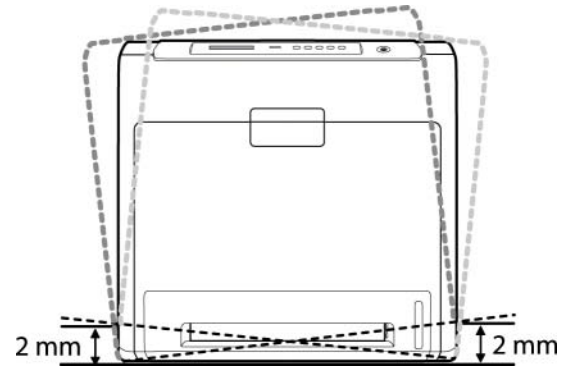

- 2 Unpack the machine and check all the enclosed items.
- 3 Remove the tape holding the machine tightly.
- 4 Install all four of the toner cartridges.
- 5 Load paper. (See "Loading paper" on page 4.4.)
- 6 Make sure that all the cables are connected to the machine.
- 7 Turn the machine on.



Caution

When you move the machine, do not tilt or turn it upside down. Otherwise, the inside of the machine may be contaminated by toner, which can cause damage to the machine or bad print quality.

Setting up the network

You need to set up the network protocols on the machine to use it as your network printer. You can set up the basic network settings with the machine's control panel.



Note

- If you want to use the USB cable, connect between a computer and your machine. Then, refer to the software installation in Software section.

Supported operating systems

The following table shows the network environments supported by the machine:

Item	Requirements
Network interface	10/100 Base-TX
Network operating system	Windows 2000/XP/2003/Vista Various Linux OS Macintosh 10.3 ~ 10.5 (CLP-610 series) Macintosh 10.1 ~ 10.5 (CLP-660 series)
Network protocols	TCP/IP
Dynamic addressing server	DHCP, BOOTP

Configuring network protocol via the machine

You can set up TCP/IP Network parameters, follow the steps listed below.



Note

If you want to setup DHCP network protocol, go to the <http://developer.apple.com/networking/bonjour/download/>, select the program Bonjour for Windows due to your computer operating system, and install the program. This program will allow you to fix the network parameter automatically. Follow the instruction in the installation window. This program does not support Linux.

- 1 Make sure your machine is connected to the network with an RJ-45 Ethernet cable.
- 2 Make sure you have turned on the machine.
- 3 Press **Menu** on the control panel, until you see **Network** on the bottom line of the display.
- 4 Press **OK** to access the menu.
- 5 Press the left/right arrow until **TCP/IP** displays.
- 6 Press **OK**.
- 7 Press the left/right arrow until **Static** displays.
- 8 Press **OK**.
- 9 Press the left/right arrow until **IP Address** displays.
- 10 Press **OK**.
- 11 Enter IP address.
 - a.Press the left/right arrow to enter a number between 0 and 255.
 - b.Press **OK**.
 - c.Repeat these steps to complete the address.
- 12 Press **Back** to go to the upper level.

- 13 Press the left/right arrow until **Subnet Mask** displays.
- 14 Press **OK**.
- 15 Enter Subnet Mask.
 - a.Press the left/right arrow to enter a number between 0 and 255.
 - b.Press **OK**.
 - c.Repeat these steps to complete Subnet Mask.
- 16 Press **Back** to go to the upper level.
- 17 Press the left/right arrow until **Gateway** displays.
- 18 Press **OK**.
- 19 Enter Gateway.
 - a.Press the left/right arrow to enter a number between 0 and 255.
 - b.Press **OK**.
 - c.Repeat these steps to complete Gateway.



Note

Contact the network administrator if you are not sure how to configure.



Note

You can also set up the network settings through the network administration programs. Refer to the user's guide on the Network Utilities CD that came with your machine.

- **SyncThru™ Web Admin Service:** Web-based printer management solution for network administrators. **SyncThru™ Web Admin Service** provides you with an efficient way of managing network devices and lets you remotely monitor and troubleshoot network machines from any sith with corporate internet access. Download this program from <http://solution.samsungprinter.com>.
- **SyncThru™ Web Service:** Web server embedded on your network print server, which allows you to:
 - Configure the network parameters necessary for the machine to connect to various network environments.
 - Customize machine settings.
- **SetIP:** Utility program allowing you to select a network interface and manually configure the IP addresses for use with the TCP/IP protocol. See Using SetIP program on page 3.5.

Installing the software

You have to install the machine software for printing. The software includes drivers, applications, and other user friendly programs.



Note

- The following procedure is for when you use the machine as a network machine. If you want to connect a machine with a USB cable, refer to the Software section.
- The following procedure is based on the Windows XP operating system. The procedure and popup window which appears during the installation may differ depending on the operating system, the printer feature, or the interface in use. (See Software section.)

1 Make sure that the network setup for your machine is completed. (See "Setting up the network" on page 3.1.) All applications should be closed on your computer before beginning installation.

2 Insert the Printer Software CD-ROM into your CD-ROM drive.

The CD-ROM should automatically run, and an installation window appears.

If the installation window does not appear, click **Start > Run**. Type X:\Setup.exe, replacing "X" with the letter which represents your drive and click **OK**.

If you use Windows Vista, click **Start > All Programs > Accessories > Run**, and type X:\Setup.exe.

3 Click **Next**.

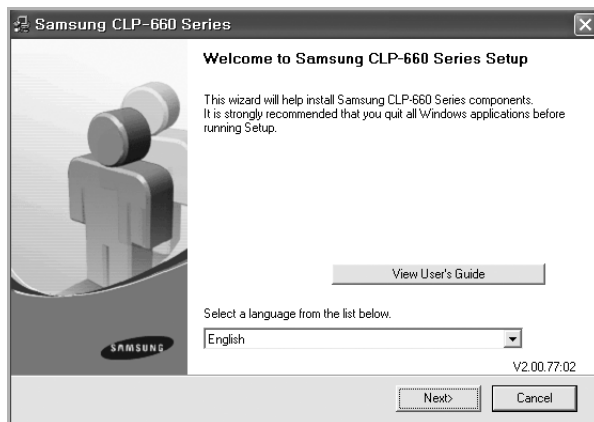

• The window above may slightly differ, if you are reinstalling the driver.

• **View User's Guide:** Allows you to view the User's Guide. If your computer does not have Adobe Acrobat, click on this option and it will automatically install Adobe Acrobat Reader for you, and then open the User's Guide.

4 Select **Typical installation for a network printer**, and then click **Next**.

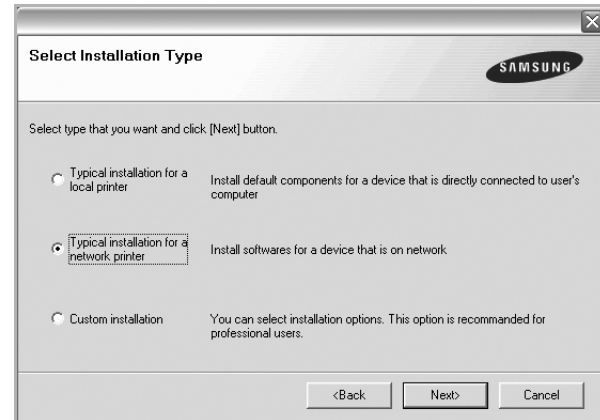

5 The list of machines available on the network appears. Select the printer you want to install from the list and then click **Next**.

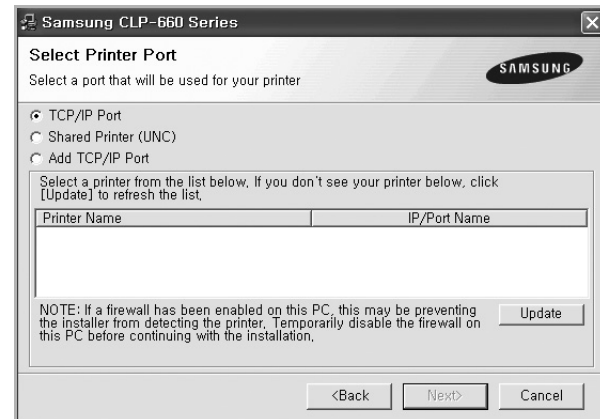

• If you do not see your machine on the list, click **Update** to refresh the list, or select **Add TCP/IP Port** to add your machine to the network. To add the machine to the network, enter the port name and the IP address for the machine.

To verify your machine's IP address or the MAC address, print a Network Configuration page. (See "Printing a machine configuration report" on page 6.1.)

• To find a shared network printer (UNC Path), select **Shared Printer [UNC]** and enter the shared name manually or find a shared printer by clicking the **Browse** button.



Note

If you are not sure of the IP address, contact your network administrator or print network information. (See "Printing a machine configuration report" on page 6.1.)

6 After the installation is finished, a window appears asking you to print a test page and to register yourself as a user of Samsung machines in order to receive information from Samsung. If you so desire, select the corresponding checkbox and click **Finish**.



Note

•If your machine does not work properly after the installation, try to reinstall the printer driver. See Software section.

•When the printer driver is in installation process, the driver installer detects the locale information of your operating system, and sets the default paper size for your machine. If you use the different Windows locale, you must change the paper size of your machine for matching your commonly used paper size. Go to the printer properties to change the paper size after installation completes.

Printer's basic settings

After installation is complete, you may want to set the printer's default settings. Refer to the next section if you would like to set or change values.

Altitude Setting after Software Installation

The print quality is affected by atmospheric pressure, which is determined by the height of the machine above sea level. The following information will guide you on how to set your machine to the best print quality or best quality of print.

Before you set the altitude value, find the altitude where you are using the machine.

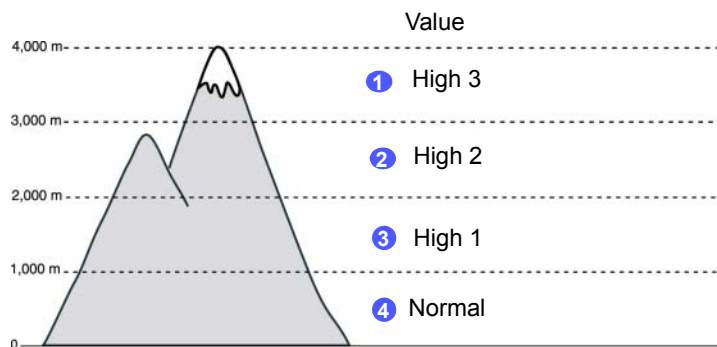

- 1 Ensure that you have installed the printer driver with the provided Printer Software CD.
- 2 Double-click the **Smart Panel** icon on the Windows task bar (or Notification Area in Linux). You can also click **Smart Panel** on the status bar in Mac OS X.
- 3 Click **Printer Setting**.

- 4 Click **Setting > Altitude Adjustment**. Select the appropriate value from the dropdown list, and then click **Apply**.



Note

If your machine is connected to a network, **SyncThru Web Service** screen appears automatically. Click **Printer Setting > Setup (or Machine Setup) > Altitude Adj.** Select the appropriate altitude value, and then click **Apply**.

Changing the display language

To change the language that appears on the display, refer to the following steps.

- 1 Press **Menu** on the control panel until you see **System Setup** on the bottom line of the display.
- 2 Press **OK** to access **System Setup**.
- 3 Press the left/right arrow until **Language** displays.
- 4 Press **OK**.
- 5 Press the left/right arrow until the language you want displays.
- 6 Press **OK**.
- 7 Press **Stop** to return to machine ready mode.

Setting job timeout

- 1 Press **Menu** on the control panel until you see **System Setup** on the bottom line of the display.
- 2 Press **OK** to access **System Setup**.
- 3 Press the left/right arrow until **Job Timeout** displays.
- 4 Press **OK**.
- 5 Press the left/right arrow to select the amount of time the machine will wait.
- 6 Press **OK**.
- 7 Press **Stop** to return to machine ready mode.

Using power saving feature

The machine provides power saving features. When the machine is not in use, you can save electricity with the provided power save mode. Set the specific time the machine goes to the power save mode.

- 1 Press **Menu** on the control panel until you see **System Setup** on the bottom line of the display.
- 2 Press **OK** to access **System Setup**.
- 3 Press the left/right arrow until **Power Save** displays.
- 4 Press **OK**.
- 5 Press the left/right arrow to select the amount of time.
- 6 Press **OK**.
- 7 Press **Stop** to return to machine ready mode.

Setting the default paper size and type

You can select the paper size you would like to keep for printing job.



Note

For detailed information on the Custom paper size setting and the paper type setting, see "Setting the paper size and type" on page 4.7.

- 1 Press **Menu** on the control panel until you see **Paper** on the bottom line of the display.
- 2 Press **OK** to access the paper setup.
- 3 Press the left/right arrow until **Paper Size** displays.
- 4 Press **OK**.
- 5 Press the left/right arrow to select the paper size such as **A4**, **Letter** or **Custom**.
- 6 Press **OK**.
- 7 Press **Stop** to return to machine ready mode.

Setting the default tray

If you want to select the particular tray for the print job, use the **Paper Source** feature.

- 1 Press **Menu** on the control panel until you see **Paper** on the bottom line of the display.
- 2 Press **OK** to access the paper setup.
- 3 Press the left/right arrow until **Paper Source** displays.
- 4 Press **OK**.
- 5 Press the left/right arrow to select the paper tray, such as **Tray 1**, **Tray 2**, **MP Tray**, **Manual Feeder** or **Auto**.



Note

If you set this menu to **Auto**, an additional menu, **Tray Chaining** appears. With **Tray Chaining**, the machine finds a secondary available tray to continue a printing job in case the primary tray, usually tray 1, is unavailable (or not ready).

- 6 Press **OK**.
- 7 Press **Stop** to return to machine ready mode.

Changing the font setting

Your machine has preset the font for your region or country. If you want to change the font which you prefer or set the font under special condition such as the DOS environment, you can change the font setting as follows:

- 1 Press **Menu** on the control panel until you see **Emulation** feature.
- 2 Press **OK** to access the font setting.
- 3 Press the left/right arrow until **Setup** displays.
- 4 Press the left/right arrow until **PCL** displays.
- 5 Press the left/right arrow until **Symbol** displays.
- 6 Press the left/right arrow until your preferred font displays.
- 7 Press **OK**.
- 8 Press **Stop** to return to machine ready mode.



Note

Following information shows the proper font list for corresponding languages.

- Russian: CP866, Cyrillic
- Hebrew: 15Q, 8H, 0H (Israel only)
- Greek: GREEK, PC737
- Arabic & Farsi: ARABIC8, WINARABIC, PC864, FARSI, ISOARABIC
- OCR : OCR-A, OCR-B

Using SetIP program

This program is for the network IP setting using the MAC address which is the hardware serial number of the network printer card or interface. Especially, it is for the network administrator to set several network IPs at the same time.

- 1 Insert the driver CD provided along with your machine.
- 2 Start Windows Explorer and open the X drive. (X represents your CD-ROM drive.)
- 3 Double click **Application > SetIP**.
- 4 Open the language folder you want to use.
- 5 Double click **Setup.exe** to install this program.

6 From the Windows Start menu, select **Programs > Samsung Network Printer Utilities > SetIP**.

7 Select the name of your printer and click “”.



Note

If you cannot find your printer name click “” to refresh the list.

8 Enter the network card's MAC address, IP address, subnet mask, default gateway, and then click **Apply**.



Note

If you do not know the network card's MAC address, print the machine's network information report.

9 Click **OK** to confirm the settings.

Click **Exit** to close the SetIP program.

4 Selecting and loading print media

This chapter introduces you how select and load print media for your machine.

This chapter includes:

- **Selecting print media**
- **Loading paper**
- **Setting the paper size and type**

Selecting print media

You can print on a variety of print media, such as plain paper, envelopes, and labels. Always use print media that meet the guidelines for use with your machine. Print media that does not meet the guidelines outlined in this user's guide may cause the following problems:

- Poor print quality
- Increased paper jams
- Premature wear on the machine.

Properties, such as weight, composition, grain, and moisture content, are important factors that affect the machine's performance and the output quality. When you choose print materials, consider the following:

- The type, size and weight of the print media for your machine are described later in this section.
- Desired outcome: The print media you choose should be appropriate for your project.
- Brightness: Some print media are whiter than others and produce sharper, more vibrant images.
- Surface smoothness: The smoothness of the print media affects how crisp the printing looks on the paper.

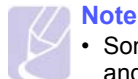

Note

- Some print media may meet all of the guidelines in this section and still not produce satisfactory results. This may be the result of improper handling, unacceptable temperature and humidity levels, or other variables over which Samsung has no control.
- Before purchasing large quantities of print media, ensure that it meets the requirements specified in this user's guide.



Caution

Using print media that does not meet these specifications may cause problems, requiring repairs. Such repairs are not covered by Samsung's warranty or service agreements.

Guidelines for selecting and storing print media

When selecting or loading paper, envelopes, or other print materials, keep these guidelines in mind:

- Always use print media that conforms with the specifications listed on page 4.2.
- Attempting to print on damp, curled, wrinkled, or torn paper can cause paper jams and poor print quality.
- For the best print quality, use only high quality copier grade paper specifically recommended for use in laser machines.
- Avoid using the following media types:
 - Paper with embossed lettering, perforations, or a texture that is too smooth or too rough
 - Erasable bond paper
 - Multi-paged paper
 - Synthetic paper and thermally reactive paper
 - Carbonless paper and Tracing paper.

Use of these types of paper could result in paper jams, chemical smells, and damage to your machine.

- Store print media in its ream wrapper until you are ready to use it. Place cartons on pallets or shelves, not on the floor. Do not place heavy objects on top of the paper, whether it is packaged or unpackaged. Keep it away from moisture or other conditions that can cause it to wrinkle or curl.
- Store unused print media at temperatures between 15 °C and 30 °C. The relative humidity should be between 10% and 70%.
- Store unused print media in a moisture-proof wrap, such as a plastic container or bag, to prevent dust and moisture from contaminating your paper.
- Load special media types one sheet at a time through the multi-purpose tray to avoid paper jams.
- To prevent print media, such as label sheets, from sticking together, remove them as they print out.

Specifications on print media

Type	Size	Dimensions	Weight ^a	Capacity ^b		
Plain paper	Letter	216 x 279 mm (8.5 x 11 inches)	<ul style="list-style-type: none"> • 60 to 105 g/m² (16 to 28 lb bond) for the tray • 60 to 163 g/m² (16 to 43 lb bond) for the multi-purpose tray 	<ul style="list-style-type: none"> • 250 sheets of 75 g/m² (20 lb bond) paper for the tray • 100 sheets of 75 g/m² (20 lb bond) in the multi-purpose tray • 500 sheets of 75 g/m² (20 lb bond) paper for optional tray 		
	Legal	216 x 356 mm (8.5 x 14 inches)				
	Folio	216 x 330 mm (8.5 x 13 inches)				
	A4	210 x 297 mm (8.26 x 11.69 inches)				
	Oficio	216 x 343 mm (8.5 x 13.5 inches)				
	JIS B5	182 x 257 mm (7.16 x 10.11 inches)				
	ISO B5	176 x 250 mm (6.93 x 9.84 inches)				
	Executive	184 x 267 mm (7.25 x 10.5 inches)				
	A5	148 x 210 mm (5.82 x 8.26 inches)			<ul style="list-style-type: none"> • 60 to 105 g/m² (16 to 28 lb bond) for the tray • 60 to 163 g/m² (16 to 43 lb bond) for the multi-purpose tray 	<ul style="list-style-type: none"> • 150 sheets of 75 g/m² (20 lb bond) paper for the tray • 100 sheets of 75 g/m² (20 lb bond) in the multi-purpose tray
	Statement	140 x 216 mm (5.5 x 8.5 inches)				
A6	105 x 148 mm (4.13 x 5.82 inches)					
Envelope	Envelope Monarch	98 x 191 mm (3.87 x 7.5 inches)	75 to 105 g/m ² (20 to 28 lb bond)	10 sheets of 75 g/m ² (20 lb bond) in the multi-purpose tray		
	Envelope No. 9	98 x 225 mm (3.87 x 8.87 inches)				
	Envelope No. 10	105 x 241 mm (4.12 x 9.5 inches)				
	Envelope DL	110 x 220 mm (4.33 x 8.66 inches)				
	Envelope C5	162 x 229 mm (6.37 x 9.01 inches)				
	Envelope C6	114 x 162 mm (4.48 x 6.38 inches)				
	Envelope 6 3/4	92 x 165 mm (3.62 x 6.5 inches)				
Labels	Letter, Legal, Folio, A4, JIS B5, ISO B5, Executive, A5, A6, Oficio, Statement	Refer to the Plain paper section	120 to 150 g/m ² (32 to 40 lb bond)	10 sheets of 75 g/m ² (20 lb bond) paper for the multi-purpose tray		
Card stock	Letter, Legal, Folio, A4, JIS B5, ISO B5, Executive, A5, A6, Oficio, Statement	Refer to the Plain paper section	90 to 163 g/m ² (24 to 43 lb bond)	10 sheets of 75 g/m ² (20 lb bond) paper for the multi-purpose tray		
Minimum size (custom)		76 x 127 mm (3 x 5 inches)	60 to 163 g/m ² (16 to 43 lb bond)			
Maximum size (custom)		216 x 356 mm (8.5 x 14 inches)				

a. If media weight is over 105 g/m² (28 lb bond), use the multi-purpose tray.

b. Maximum capacity may differ depending on media weight, thickness, and environmental conditions.

Media sizes supported in each mode

Mode	Size	Weight	Source
Single side printing	All sizes supported by the machine	All weights supported by the machine	<ul style="list-style-type: none"> • tray 1 • optional tray • multi-purpose tray
Duplex printing ^a	Letter, A4, Legal, Folio, Oficio	75 to 90 g/m ² (20 to 24 lb bond)	<ul style="list-style-type: none"> • tray 1 • optional tray • multi-purpose tray

a. 75 to 105 g/m² (20 ~ 28 lb bond) only, and this feature is supported in CLP-6xxND.

Guidelines for special print media

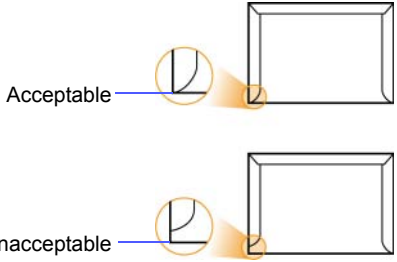
Media type	Guidelines
Envelopes	<ul style="list-style-type: none"> • Successful printing on envelopes depends upon the quality of the envelopes. When selecting envelopes, consider the following factors: <ul style="list-style-type: none"> - Weight: The weight of the envelope paper should not exceed 90 g/m² or jamming may occur. - Construction: Prior to printing, envelopes should lie flat with less than 6 mm curl, and should not contain air. - Condition: Envelopes should not be wrinkled, nicked, or otherwise damaged. - Temperature: You should use envelopes that are compatible with the heat and pressure of the machine during operation. • Use only well-constructed envelopes with sharp and well creased folds. • Do not use stamped envelopes. • Do not use envelopes with clasps, snaps, windows, coated lining, self-adhesive seals, or other synthetic materials. • Do not use damaged or poorly made envelopes. • Be sure the seam at both ends of the envelope extends all the way to the corner of the envelope. 

Media type	Guidelines
	<ul style="list-style-type: none"> • Envelopes with a peel-off adhesive strip or with more than one flap that folds over to seal must use adhesives compatible with the machine's fusing temperature for 0.1 second. Check your machine's specification to view the fusing temperature, see page 10.1. The extra flaps and strips might cause wrinkling, creasing, or jams, and may even damage the fuser. • For the best print quality, position margins no closer than 15 mm from the edges of the envelope. • Avoid printing over the area where the envelope's seams meet.
Labels	<ul style="list-style-type: none"> • To avoid damaging the machine, use only labels designed for use in laser machines. • When selecting labels, consider the following factors: <ul style="list-style-type: none"> - Adhesives: The adhesive material should be stable at your machine's fusing temperature. Check your machine's specification to view the fusing temperature, see page 10.1. - Arrangement: Only use labels with no exposed backing between them. Labels can peel off sheets that have spaces between the labels, causing serious jams. - Curl: Prior to printing, labels must lie flat with no more than 13 mm of curl in any direction. - Condition: Do not use labels with wrinkles, bubbles, or other indications of separation. • Make sure that there is no exposed adhesive material between labels. Exposed areas can cause labels to peel off during printing, which can cause paper jams. Exposed adhesive can also cause damage to machine components. • Do not run a sheet of labels through the machine more than once. The adhesive backing is designed for only a single pass through the machine. • Do not use labels that are separating from the backing sheet or are wrinkled, bubbled, or otherwise damaged.
Card stock or custom-sized materials	<ul style="list-style-type: none"> • Do not print on media smaller than 76 mm wide or 356 mm long. • In the software application, set margins at least 6.4 mm away from the edges of the material.

Media type	Guidelines
Preprinted paper	<ul style="list-style-type: none"> • Letterhead must be printed with heat-resistant ink that will not melt, vaporize, or release hazardous emissions when subjected to the printer's fusing temperature for 0.1 second. Check your machine's specification to view the fusing temperature, see page 10.1. • Letterhead ink must be non-flammable and should not adversely affect printer rollers. • Forms and letterhead should be sealed in a moisture-proof wrapping to prevent changes during storage. • Before you load preprinted paper, such as forms and letterhead, verify that the ink on the paper is dry. During the fusing process, wet ink can come off preprinted paper, reducing print quality.



Caution

Using photographic paper or coated paper may cause problems, requiring repairs. Such repairs are not covered by Samsung's warranty or service agreements.

Loading paper

In the tray

Load the print media you use for the majority of your print jobs in tray 1. Tray 1 can hold a maximum of 250 sheets of 75 g/m² (20 lb bond) plain paper.

You can purchase an optional tray and attach it below the standard tray to load an additional 500 sheets of paper. (See "Accessories" on page 8.1.)

Loading paper in the tray 1 or optional tray

- 1 To load paper, pull and open the paper tray and place paper with the side you want to print facing up.

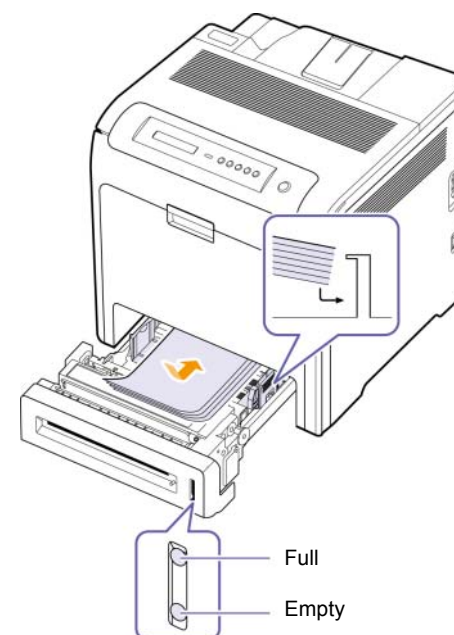

- 2 After loading paper, set the paper type and size for the tray 1. See Software section for PC-printing.



Note

- If you experience problems with paper feed, place one sheet at a time in the multi-purpose tray.
- You can load previously printed paper. The printed side should be facing up with an uncurled edge at the front. If you experience problems with paper feed, turn the paper around. Note that print quality is not guaranteed.

Changing the size of the paper in the paper tray

To load longer sizes of paper, such as Legal-sized paper, you need to adjust the paper guides to extend the paper tray.

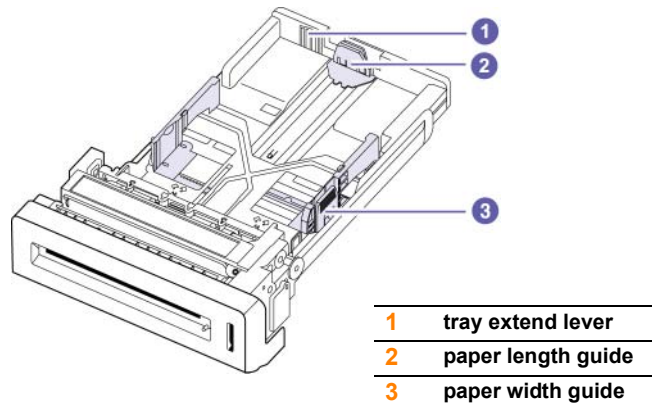

- 1 Adjust the paper length guide to the desired paper length. It is preset to Letter or A4 size depending on the country.

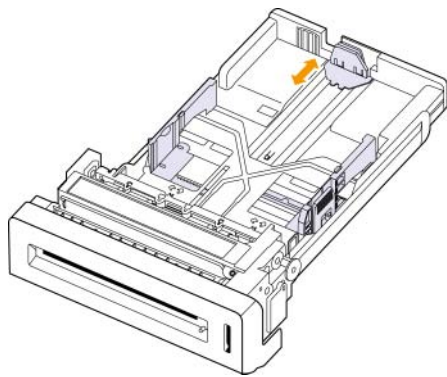

- 2 After inserting paper into the tray, while pinching the paper width guide as shown, move it toward the stack of paper until it lightly touches the side of the stack. Do not press the guide too tightly to the edge of the paper; the guide may bend the paper.

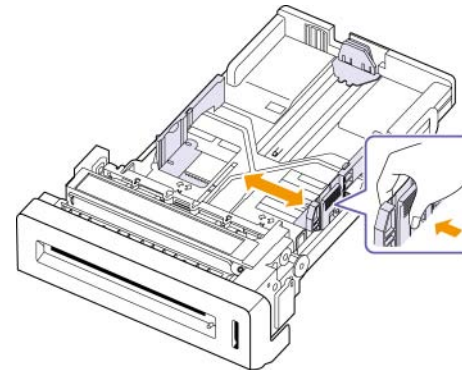

When you use legal-sized paper, you need to extend the length of the tray.

- 3 Press and hold the green lever on the back of the tray, when you are holding the lever, extend the tray to the corresponding position.

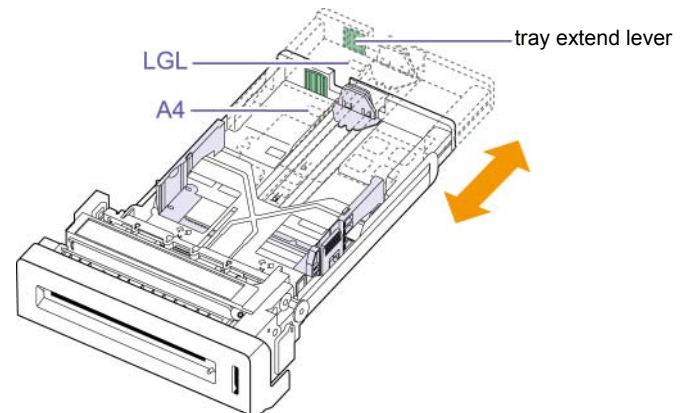

- 4 Load the paper into the tray.
- 5 Place the tray into the machine.
- 6 Set the paper size from your computer. (See page 4.7)



Note

- Do not push the paper width guides far enough to cause the materials to warp.
- If you do not adjust the paper width guides, it may cause paper jams.



In the multi-purpose tray

The multi-purpose tray can hold special sizes and types of print material, such as postcards, note cards, and envelopes. It is useful for single page printing on letterhead or colored paper.

Tips on using the multi-purpose tray

- Load only one size of print media at a time in the multi-purpose tray.
- To prevent paper jams, do not add paper when there is still paper in the multi-purpose tray. This also applies to other types of print media.
- Print media should be loaded face down with the top edge going into the multi-purpose tray first and be placed in the center of the tray.
- Always load only the specified print media to avoid paper jams and print quality problems. (See "Selecting print media" on page 4.1.)
- Flatten any curl on postcards, envelopes, and labels before loading them into the multi-purpose tray.

To load paper in the multi-purpose tray:

- 1 Hold the handle of multi-purpose tray and pull it down to open.

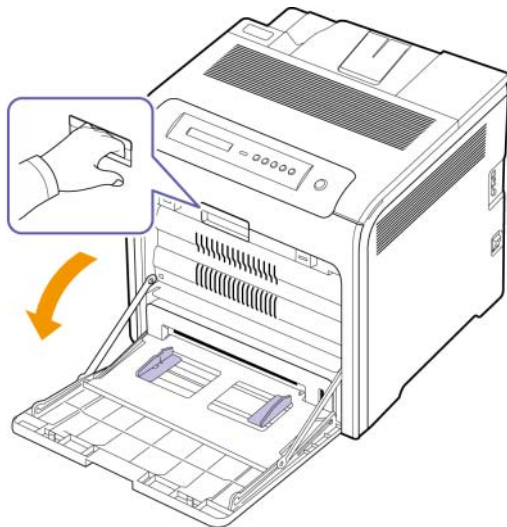

- 2 If you are using paper, flex or fan the edge of the paper stack to separate the pages before loading.

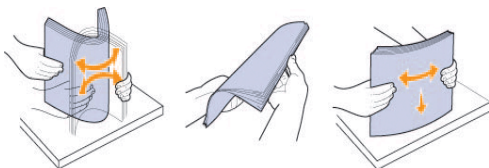

- 3 Load the paper.

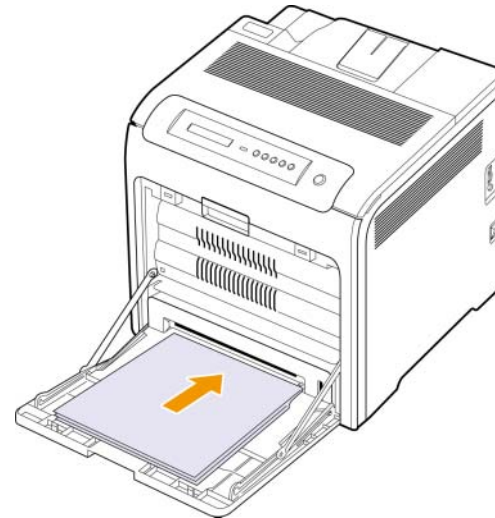

Note

If you want to load the used paper which one side has been printed already, place the paper with the used side facing up.

- 4 Squeeze the multi-purpose tray paper width guides and adjust them to the width of the paper. Do not force too much, or the paper will be bent, which will result in a paper jam or skew.

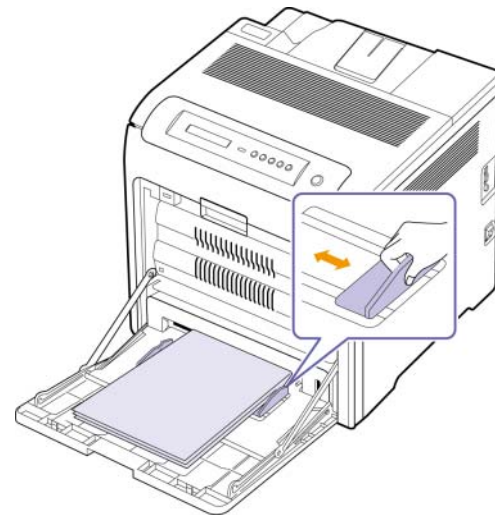



Note

Depending on the media type you are using, keep the following loading guidelines:

- Envelopes: Place an envelope's flap side up, stamp area bottom right.
- Labels: Print side up and top short edge entering the machine first.
- Preprinted paper: Place the design side down with top-edge toward the machine.
- Card stock: Print side up and the short edge entering the machine first.
- Previously printed paper: Previously printed side up with an uncurled edge toward the machine.

- 5 After loading paper, set the paper type and size for the multi-purpose tray. See Software section for PC-printing.



Note

The settings made from the printer driver override the settings on the control panel.

- 6 After printing, close the multi-purpose tray.

Setting the paper size and type

The settings you change remain in effect only while you are using the current program. To make your changes permanent, make them in the Printers folder.



Note

The following procedure is for Windows XP. For other Windows OS, refer to the corresponding Windows User's Guide or online help.

- 1 Click the **Start** button on the computer screen.
- 2 Select **Printers and Other Hardware**.
- 3 Select **Printers and Faxes**.
- 4 Right-click on the printer driver icon and select **Printing Preferences**.
- 5 Click the **Paper** tab, and change the settings on **Paper Options**.
- 6 Click **OK**.

5 Basic printing

This chapter explains common printing tasks.

Printing a document

Your machine allows you to print from various Windows, Macintosh, or Linux applications. The exact steps for printing a document may vary depending on the application you use.

- 1 Open the document you want to print.
- 2 Select **Print** from the **File** menu. The Print window is displayed. It may look slightly different depending on your application.
- 3 Select **your printer driver** from the **Selet Printer** drop-down list.
- 4 To start the print job, click **OK** or **Print** in the **Print** window.

For details about printing, see Software section.

Canceling a print job

If the print job is waiting in a print queue or print spooler, such as the printer group in Windows, delete the job as follows:

- 1 Click the Windows **Start** menu.
- 2 For Windows 2000, select **Settings** and then **Printers**.
For Windows XP/2003, select **Printers and Faxes**.
For Windows Vista, select **Control Panel > Hardware and Sound > Printers**.
- 3 Double-click the **Samsung CLP-6xx Series** icon. (Or **Samsung CLP-6xx Series PS**)
- 4 From the **Document** menu, select **Cancel**.



Note

You can also access this window by simply double-clicking the printer icon at the bottom right corner of the Windows desktop.

You can also cancel the current job by pressing **Stop** on the control panel.

6 Maintenance

This chapter provides information for maintaining your machine and the toner cartridge.

This chapter includes:

- **Printing a machine configuration report**
- **Printing a network report**
- **Monitoring the supplies' life**
- **Cleaning your machine**
- **Maintaining the cartridge**
- **Redistributing toner**
- **Replacing the toner cartridge**
- **Replacing the paper transfer belt**
- **Maintenance parts**
- **Managing your machine from the website**

Printing a machine configuration report

You can print the machine's information.

- 1 Press **Menu** on the control panel until you see **Information** on the bottom line of the display.
- 2 Press **OK**.
- 3 Press the left/right arrow until **Configuration** displays.
- 4 Press **OK**.
- 5 The display shows **Print?**, then press **OK** to print the configuration report.

Printing a network report

You can print the machine's network information such as the protocol type you set, IP address and so forth.

- 1 Press **Menu** on the control panel until you see **Network** on the bottom line of the display.
- 2 Press **OK**.
- 3 Press the left/right arrow button until **Network Info.** displays.
- 4 Press **OK**.
- 5 The display shows **Print?**, then press **OK** to print the configuration report.

Monitoring the supplies' life

If you want to view the supply life indicators, follow the next step.

- 1 Press **Menu** on the control panel until you see **System Setup** on the bottom line of the display.
- 2 Press **OK**.
- 3 Press the left/right arrow until **Maintenance** displays.
- 4 Press **OK**.
- 5 Press the left/right arrow until **Supplies Life** displays.
- 6 Press **OK**.
- 7 The display shows two options as you press the left/right arrow button.
 - **Total**: displays the total number of pages printed.
 - **Toner Remains**: displays how much toner remains in the cartridge.
- 8 When you select the option, press **OK** to browse the life.

Cleaning your machine

To maintain print quality, follow the cleaning procedures below each time the toner cartridge is replaced.



Caution

- Cleaning the machine cabinet with cleaning materials that contain large amounts of alcohol, solvent, or other strong substances can discolor or damage the cabinet.
- If your machine or its surrounding is contaminated with toner, we recommend you to use a cloth or tissue dampened with water to clean it. If you use a vacuum cleaner, toner blown into the air may be harmful to you.

Cleaning the outside

Clean the machine cabinet with a soft, lint-free cloth. You can dampen the cloth slightly with water, but be careful not to let any water drip onto or into the machine.

Cleaning the inside

During the printing process, paper, toner and dust particles can accumulate inside the machine. This buildup can cause print quality problems, such as toner specks or smearing. Cleaning the inside of the machine clears or reduces these problems. Contact a service representative to clean the parts inside the machine.

- 1 Power off the machine and unplug the power cable.

- 2 Using the handle, completely open the front cover.

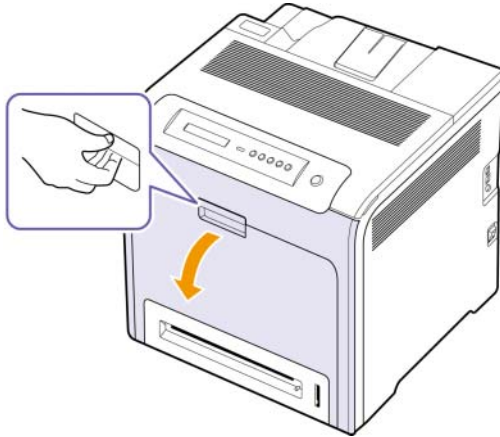

Caution

- Do not touch the green surface, the OPC drum or the front of the toner cartridge, with your hands or any other material. Use the handle on each cartridge in order to avoid touching this area.
- Be careful not to scratch the surface of the paper transfer belt.
- If you leave the front cover open for more than a few minutes, the OPC drum can be exposed to light. This will cause damage to the OPC drum. Cover the toner cartridge's OPC drum with some paper could avoid damaging it from the light while you clean the inside.

- 3 Grasp the handles on the toner cartridge and pull to remove the cartridge from the machine.

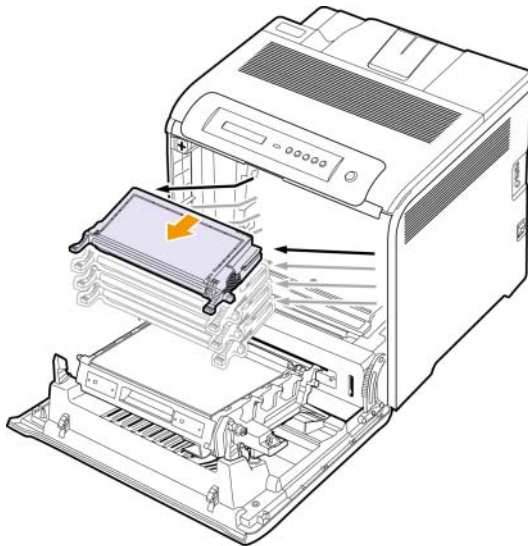

Caution

If you open the front door, be careful not to touch the underneath of the control panel (the lower part of the fuser unit). The temperature of the fuser unit might be high and could damage your skin.

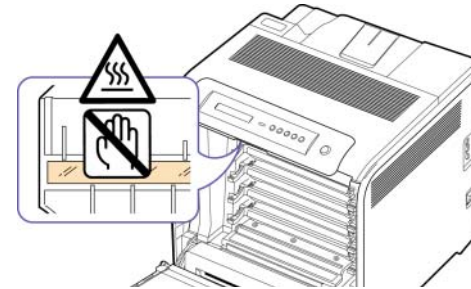

Note

When you open the front door and work inside the machine, it is highly recommend that you remove the paper transfer belt first. Because the work you do could contaminate the paper transfer belt.

- 4 Press the green release handle to release the paper transfer belt. Holding the handle on the paper transfer belt, lift it out of the machine.

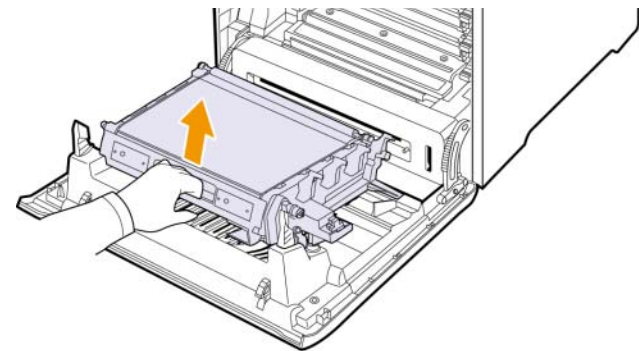

- 5 Locate the long strip of glass (LSU) inside the cartridge compartment, and gently swab the glass to see if dirt turns the white cotton black.

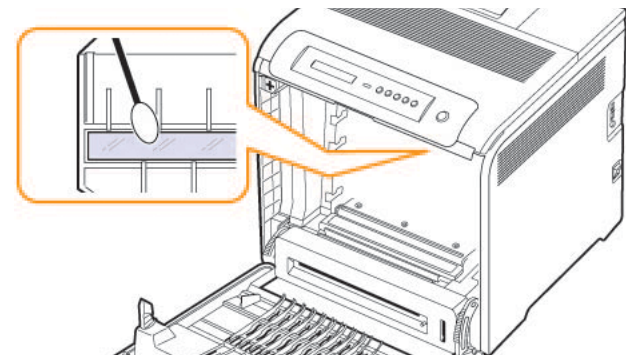

- 6 With a dry lint-free cloth, wipe away any dust and spilled toner from the toner cartridges area and their cavities.

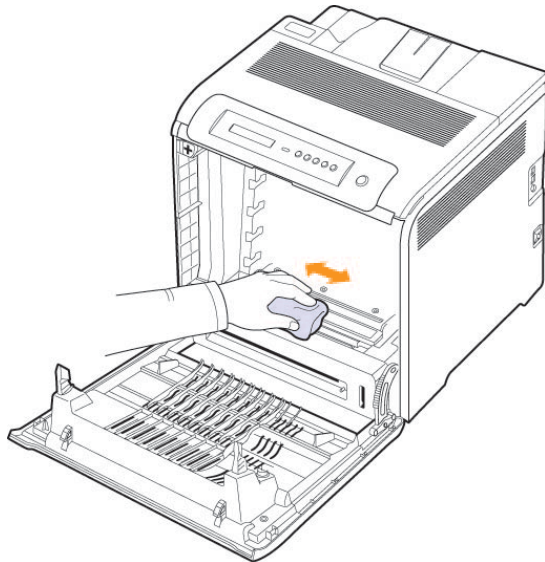

Note

If toner gets on your clothing, wipe it off with a dry cloth and wash it in cold water. Hot water sets toner into fabric.

- 7 Reinstall all the compartments into the machine, and close the front door.

Maintaining the cartridge

toner cartridge storage

To get the most from the toner cartridge, keep the following guidelines in mind:

- Do not remove the toner cartridge from its package until ready for use.
- Do not refill the toner cartridge. The machine warranty does not cover damage caused by using a refilled cartridge.
- Store toner cartridges in the same environment as your machine.
- To prevent damage to the toner cartridge, do not expose it to light for more than a few minutes.

Expected cartridge life

The life of the toner cartridge yield depends on the amount of toner that print jobs require. The actual number may also be different depending on the print density of the pages you print on, and the number of pages may be affected by operating environment, printing interval, media type, and media size. If you print a lot of graphics, you may need to change the cartridge more often.

Redistributing toner

When a toner is low, faded or light areas may appear. It is possible that colored images may be printed with incorrect colors due to flawed mixing of toner colors when one of the colored toner cartridges is low on toner. You can temporarily improve print quality by redistributing the toner.

- The toner-related message saying that the toner is low may appear on the display.
- The SmartPanel program window appears on the computer telling you which color cartridge is low on toner.

- 1 Using the handle, completely open the front cover.

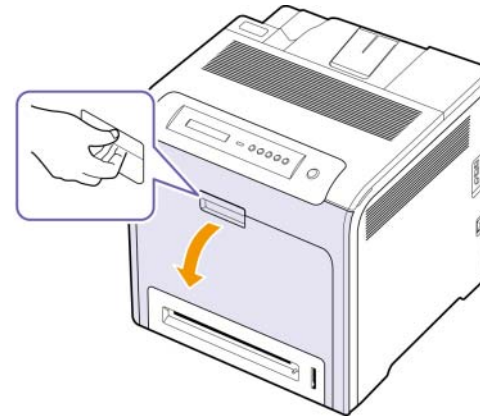

Caution

- Do not touch the green surface, the OPC drum or the front of the toner cartridge, with your hands or any other material. Use the handle on each cartridge in order to avoid touching this area.
- Be careful not to scratch the surface of the paper transfer belt.
- If you leave the front cover open for more than a few minutes, the OPC drum can be exposed to light. This will cause damage to the OPC drum. Close the front cover should the installation need to be halted for any reason.

- 2 Grasp the handles on the toner cartridge and pull to remove the cartridge from the machine.

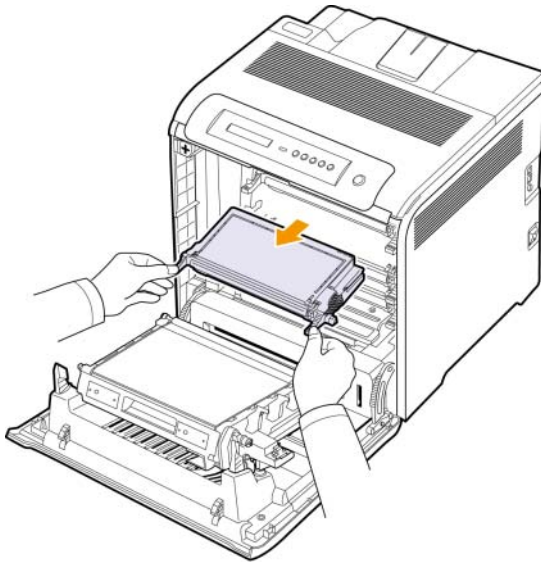
**Caution**

If you open the front door, be careful not to touch the underneath of the control panel (the lower part of the fuser unit). The temperature of the fuser unit might be high and could damage your skin.

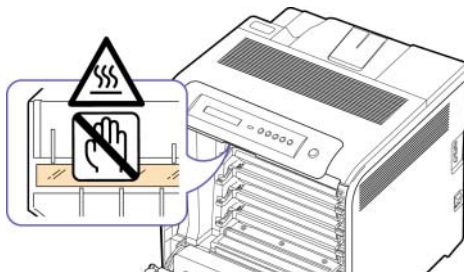
**Note**

When you open the front door and work inside the machine, it is highly recommend that you remove the paper transfer belt first. Because the work you do could contaminate the paper transfer belt.

- 3 Holding both handles on the toner cartridge, thoroughly rock it from side to side to redistribute the toner.

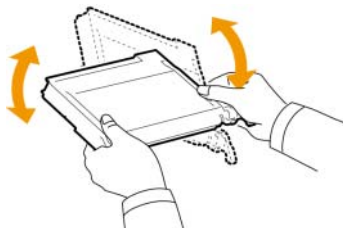
**Note**

If toner gets on your clothing, wipe it off with a dry cloth and wash it in cold water. Hot water sets toner into fabric.

- 4 Slide the toner cartridge back into the machine.
- 5 Close the front cover. Make sure the cover is securely latched.

**Caution**

If the front cover is not completely closed, the machine will not operate.

Replacing the toner cartridge

The machine uses four colors and has a different toner cartridge for each one: yellow (Y), magenta (M), cyan (C), and black (K).

- The status LED and the toner-related message on the display indicate which individual toner cartridge should be replaced.

At this stage, the toner cartridge needs to be replaced. Check the type of toner cartridge for your machine. (See "Supplies" on page 8.1.)

- 1 Turn the machine off, then wait a few minutes for the machine to cool.
- 2 Using the handle, completely open the front cover.

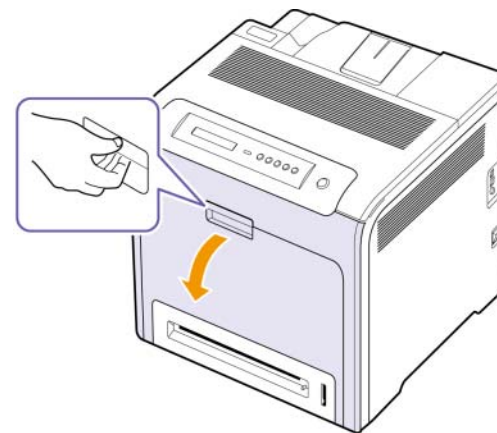
**Caution**

- Do not touch the green surface, the OPC drum or the front of each toner cartridge, with your hands or any other material. Use the handle on each cartridge in order to avoid touching this area.
- Be careful not to scratch the surface of the paper transfer belt.
- If you leave the front cover open for more than a few minutes, the OPC drum can be exposed to light. This will cause damage to the OPC drum. Close the front cover should the installation need to be halted for any reason.

- 3 Grasp the handles on the empty toner cartridge and pull to remove the cartridge from the machine.

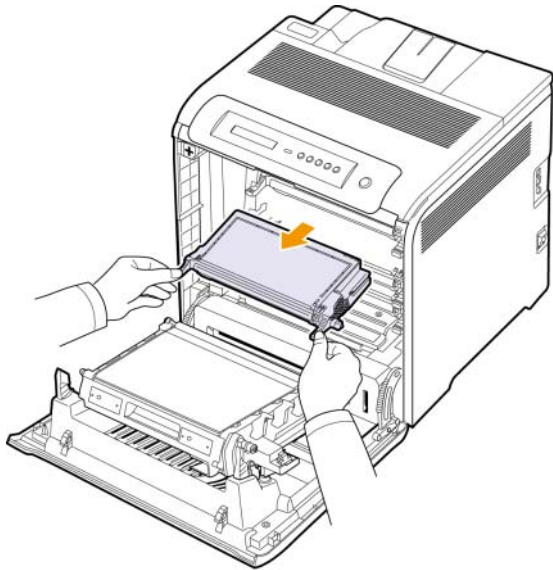

Caution

If you open the front door, be careful not to touch the underneath of the control panel (the lower part of the fuser unit). The temperature of the fuser unit might be high and could damage your skin.

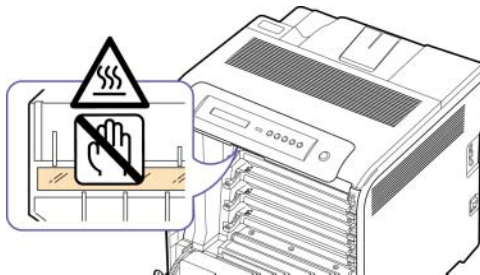

Note

When you open the front door and work inside the machine, it is highly recommend that you remove the paper transfer belt first. Because the work you do could contaminate the paper transfer belt.

- 4 Take a new toner cartridge out of its package.



Caution

- Don't use sharp objects, such as a knife or scissors, to open the toner cartridge package. You could damage the surface of the toner cartridge.
- To prevent damage, do not expose the toner cartridge to light for more than a few minutes. Cover it with a piece of paper to protect it if necessary.

- 5 Holding both handles on the toner cartridge, thoroughly rock it from side to side to evenly distribute the toner.

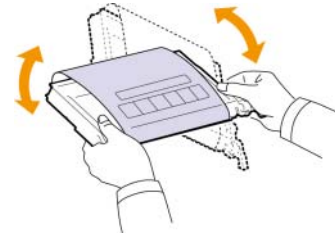

- 6 Place the toner cartridge on a flat surface, as shown, and remove the paper covering the toner cartridge by removing the tape.



Note

If toner gets on your clothing, wipe it off with a dry cloth and wash it in cold water. Hot water sets toner into fabric.

- 7 Make sure the color of the toner cartridge matches the color slot and then grasp the handles on the toner cartridge. Insert the cartridge until it clicks into place.
- 8 Close the front cover. Make sure the cover is securely latched, and then turn the machine on.



Caution

If the front cover is not completely closed, the machine will not operate.

Replacing the paper transfer belt

The life of the paper transfer belt is approximately 50,000 black and color pages. After the life span of the paper transfer belt is complete, you have to replace it.

- The transfer belt-related message appears on the display, telling it's time for a replacement.
- The SmartPanel program window appears on the computer telling you the paper transfer belt needs to be replaced.



Note

The life span of the paper transfer belt may be affected by operating environment, printing interval, media type, and media size.

- 1 Turn the machine off, then wait a few minutes for the machine to cool.
- 2 Using the handle, completely open the front cover.

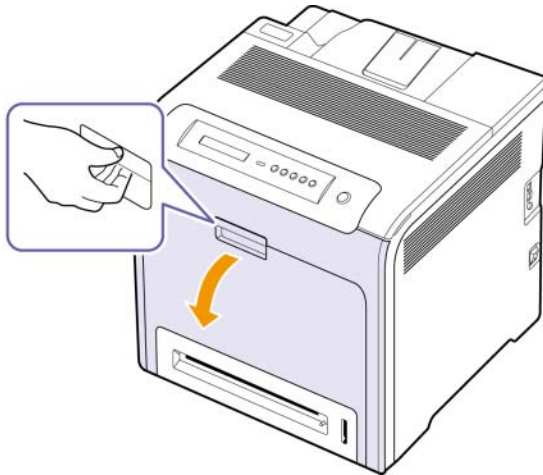

Caution

Be careful not to scratch the surface of the paper transfer belt.

- 3 Press the green release handle to release the paper transfer belt. Holding the handle on the paper transfer belt, lift it out of the machine.

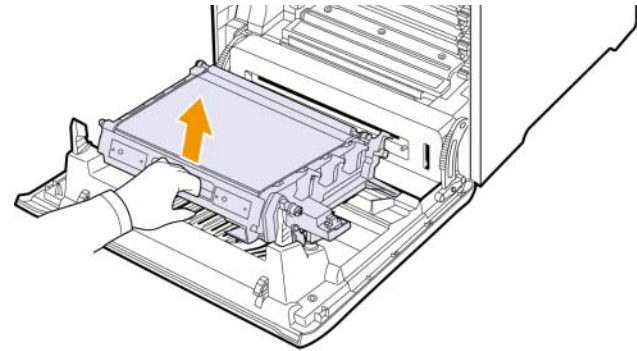

- 4 Take a new paper transfer belt out of its package.



Caution

- Don't use sharp objects, such as a knife or scissors, to open the paper transfer belt package. You could damage the surface of the paper transfer belt.
- Be careful not to scratch the surface of the paper transfer belt.

- 5 Holding the handle on the new paper transfer belt, align it with the slots on the inside of the front cover.

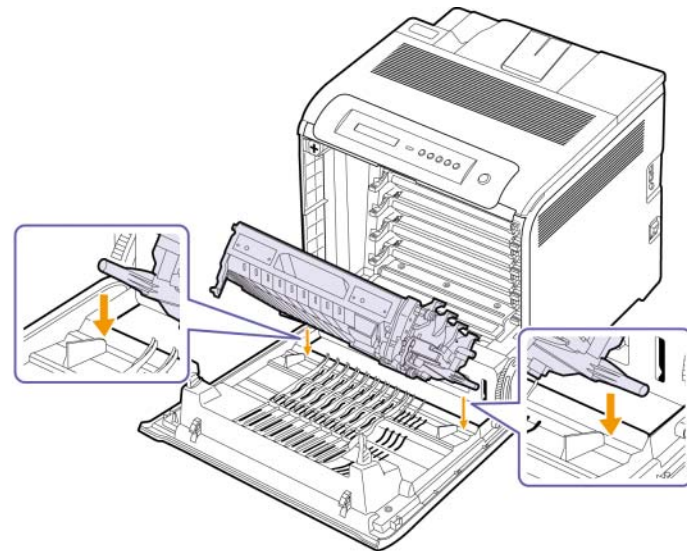

- 6 Lower the paper transfer belt until it is parallel with the front cover and firmly seated.

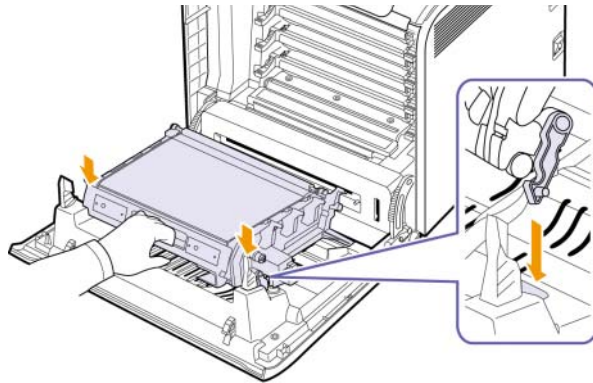

- 7 Close the front cover firmly.



Caution

If the front cover is not completely closed, the machine will not operate.

- 8 Turn the machine on.

Maintenance parts

To avoid print quality and paper feed problems resulting from worn parts, and to maintain your machine in top working condition, the following items will need to be replaced after the specified number of pages, or when the life span of each item has expired.

Items	Yield (Average)
Multi-purpose tray friction pad	Approximately 70,000 pages
Multi-purpose tray pick up roller	Approximately 70,000 pages
Fuser unit	Approximately 100,000 pages
Paper pick up roller	Approximately 70,000 pages
FCF friction pad	Approximately 70,000 pages

We highly recommend that this maintenance be performed by an authorized service provider, dealer or the retailer where you bought the machine. The warranty does not cover the replacement of the maintenance parts after their lifespan.

Managing your machine from the website

If you have connected your machine to a network and set up TCP/IP network parameters correctly, you can manage the machine via Samsung's **SyncThru™ Web Service**, an embedded web server. Use **SyncThru™ Web Service** to:

- View the device information and check its current status.
- Change TCP/IP parameters and set up other network parameters.
- Change the printer properties.
- Set the machine to send email notifications and update you on the machine's status.
- Get support for using the machine.

To access **SyncThru™ Web Service**:

- 1 Start a web browser, such as Internet Explorer, from Windows.
- 2 Enter the machine IP address (<http://xxx.xxx.xxx.xxx>) in the address field and press the **Enter** key or click **Go**.

Your machine's embedded website opens.

7 Troubleshooting

This chapter gives helpful information on what to do if you encounter a problem.

This chapter includes:

- **Tips for avoiding paper jams**
- **Clearing paper jams**
- **Understanding display messages**
- **Solving other problems**

Tips for avoiding paper jams

By selecting the correct media types, most paper jams can be avoided. When a paper jam occurs, follow the steps outlined on page 7.1.

- Follow the procedures on page 4.4. Ensure that the adjustable guides are positioned correctly.
- Do not overload the tray. Ensure that the paper level is below the paper capacity mark on the inside of the tray.
- Do not remove paper from the tray while your machine is printing.
- Flex, fan, and straighten paper before loading.
- Do not use creased, damp, or highly curled paper.
- Do not mix paper types in a tray.
- Use only recommended print media. (See "Setting the paper size and type" on page 4.7.)

Clearing paper jams

When a paper jam occurs, the warning message appears on the display screen. Refer to the table below to locate and clear the paper jam.

Message	Location of jam	Go to
MP Tray Paper Jam 0	In the multi-purpose tray	Page 7.3
Tray 2 Paper Jam 0	In the optional tray	Page 7.6
Paper Jam 0 Open/Close Door	In the paper feed area and inside the machine	Page 7.1, Page 7.4
Paper Jam 1 Open/Close Door	Inside the machine	Page 7.1, Page 7.4
Paper Jam 2 Check Inside	Inside the machine and in the exit area	Page 7.1, Page 7.5
Duplex Jam 0 Check Inside*	Inside the machine	Page 7.1



Note

The symbol * denotes an optional feature depending on machines.



Caution

To avoid tearing the paper, pull the jammed paper out gently and slowly. Follow the instructions in the following sections to clear the jam.

In the paper feed area

If paper is jammed in the paper feed area, follow the next steps to release the jammed paper.

- 1 Using the handle, completely open the front cover.

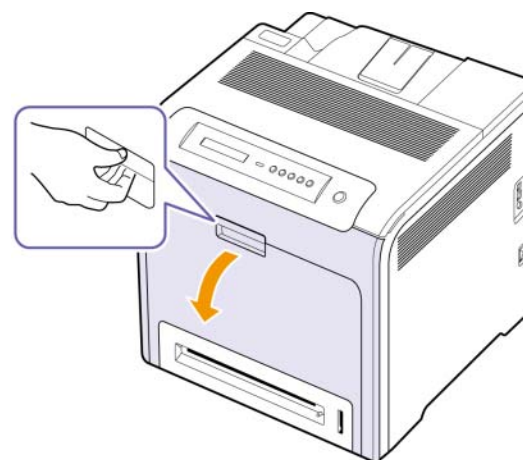

- 2 Carefully remove the paper by pulling in the direction as shown below. Go to step 7.

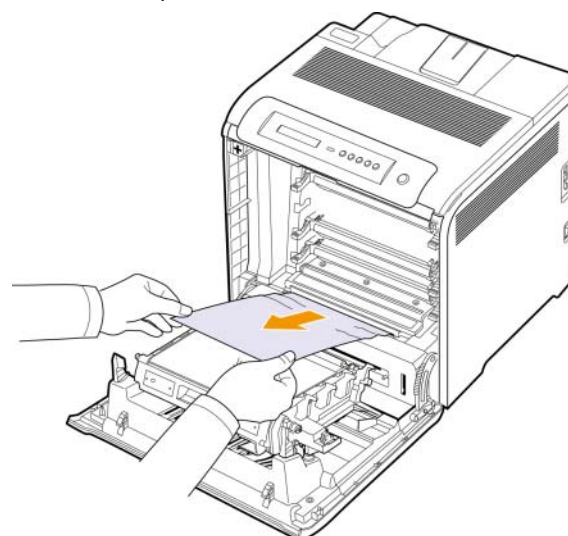

If you cannot find the jammed paper, or if there is any resistance removing the paper, stop pulling, and go to step 3.



Caution

- Do not touch the green surface, the OPC drum or the front of each toner cartridge, with your hands or any other material. Use the handle on each cartridge in order to avoid touching this area.
- Be careful not to scratch the surface of the paper transfer belt.
- If you leave the front cover open for more than a few minutes, the OPC drum can be exposed to light. This will cause damage to the OPC drum. Close the front cover should the installation need to be halted for any reason.

3 Close the front cover.

4 Pull the tray open.

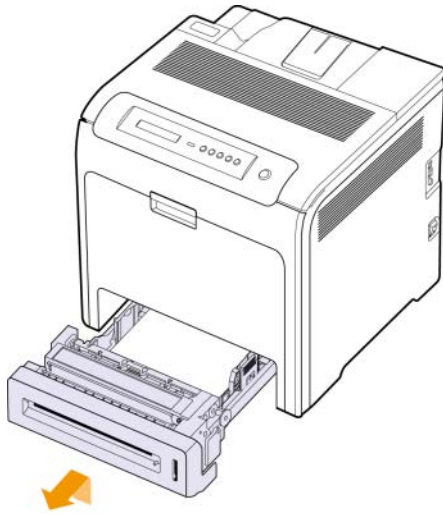

5 Remove the jammed paper by gently pulling it straight out as shown below.

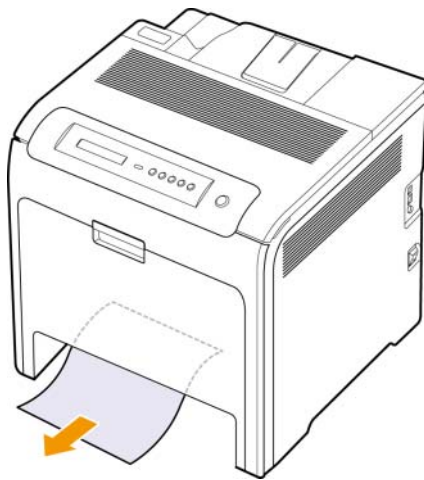

6 To replace the tray, lower the rear edge, align it with the slot, and slide it into the machine.

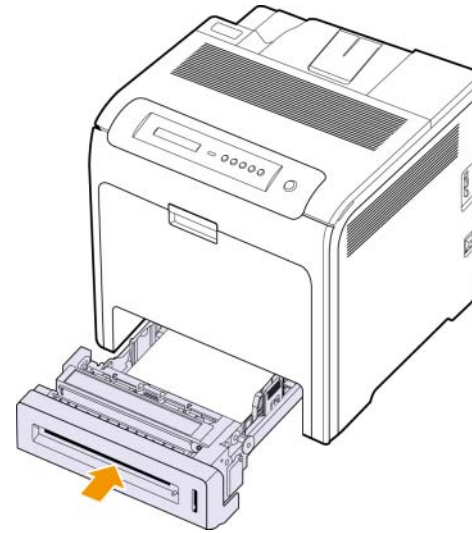

7 Open the front cover and close it. The machine will resume printing.

In the multi-purpose tray

When you print using the multi-purpose tray and the machine detects that there is either no paper or that the paper has been improperly loaded, follow the next steps to release the jammed paper.

- 1 Check if the paper is stuck in the feeding area, and if so, pull it out gently and slowly.

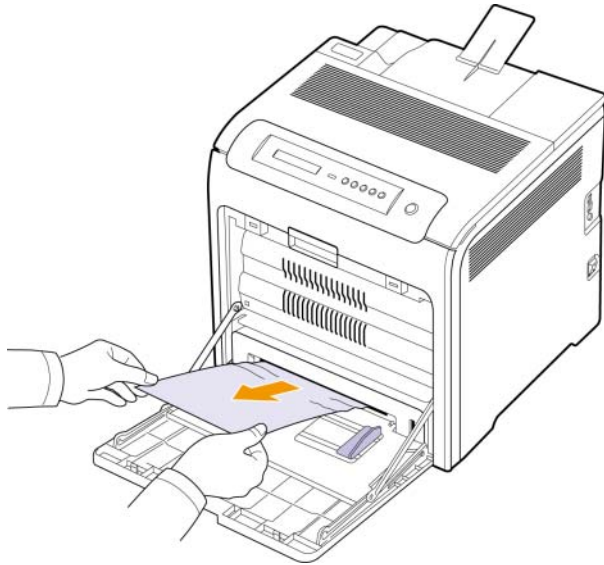

If you cannot find the jammed paper, or if there is any resistance removing the paper, stop pulling and go to step 2.

- 2 Close the multi-purpose tray.
- 3 Pull the tray1 out.
- 4 Open the inner cover while you are releasing the inner cover locks on each side of tray1 with two hands.

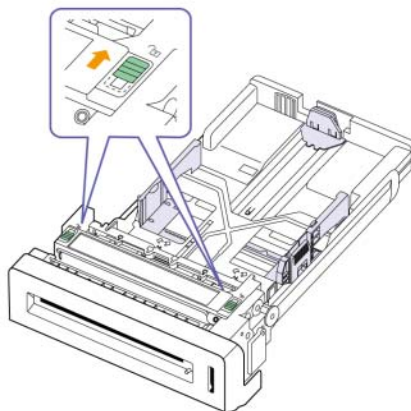

- 5 Pull the paper out gently.

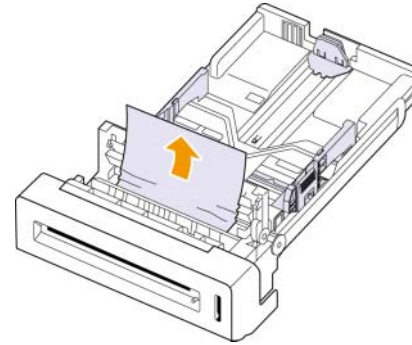

- 6 Close the inner cover.

- 7 Replace the tray.

If you cannot find the jammed paper, or if there is any resistance removing the paper, stop pulling and go to step 8.

- 8 Using the handle, completely open the front cover.

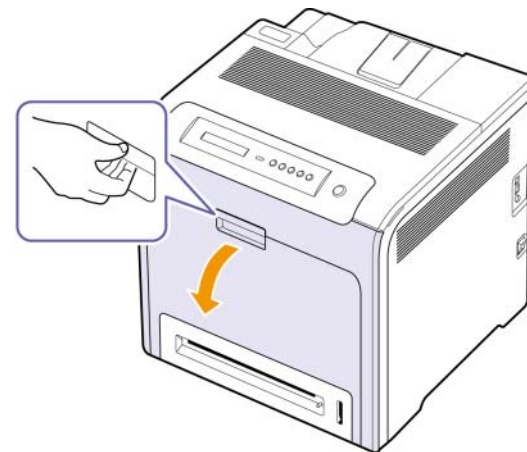

- 9 Remove the jammed paper by pulling in the direction shown. To avoid tearing the paper, pull it out gently and slowly.

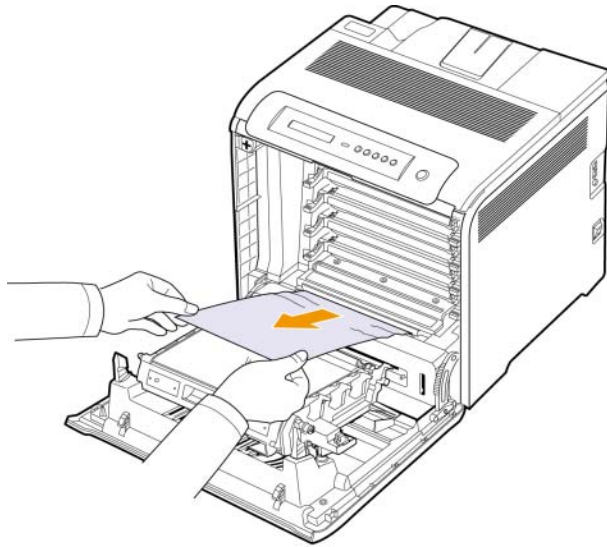

Caution

- Do not touch the green surface, the OPC drum or the front of each toner cartridge, with your hands or any other material. Use the handle on each cartridge in order to avoid touching this area.
- Be careful not to scratch the surface of the paper transfer belt.
- If you leave the front cover open for more than a few minutes, the OPC drum can be exposed to light. This will cause damage to the OPC drum. Close the front cover should the installation need to be halted for any reason.

- 10 Close the front cover firmly. The machine will resume printing.



Caution

- If the front cover is not completely closed, the machine will not operate.

In the fuser unit area

If paper is jammed in the fuser unit area, follow the next steps to release the jammed paper.

- 1 Open the top cover.

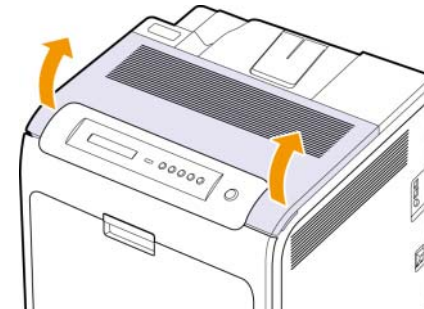

- 2 Open the inner cover using the handle on it.

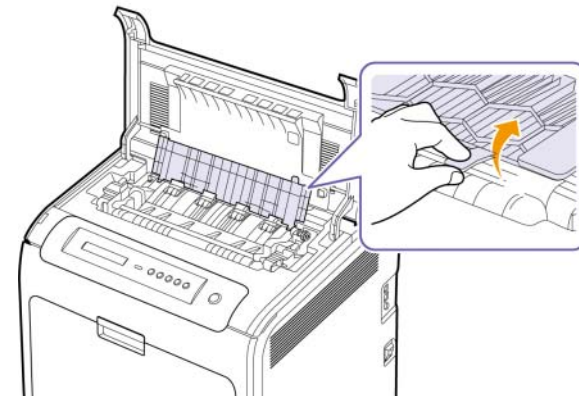

Caution

Do not touch the fuser inside the inner cover. It is hot and could cause burns! The fuser's operating temperature is 180°C (356°F). Take care when removing paper from the machine.

- 3 Pull up the paper jam lever to release the fusing part of the fuser unit and carefully take the jammed paper out of the machine.

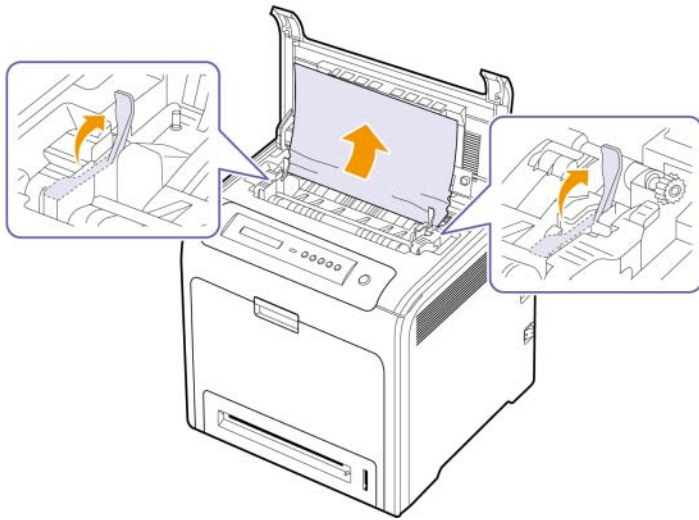

- 4 Press down the paper jam lever to fasten the fusing part.
- 5 Close the inner cover.
- 6 After removing the jammed paper, check for paper which may be jammed in other parts of the machine.
- 7 Close the top cover. Make sure that it is securely latched.



Caution

If the top cover is not completely closed, the machine will not operate.

In the paper exit area

If paper is jammed in the paper exit area, follow the next steps to release the jammed paper.

- 1 If a long portion of the paper is visible, pull it straight out. Open and close the front cover firmly. The machine will resume printing.



If you cannot find the jammed paper, or if there is any resistance removing the paper, stop pulling and go to step 2.

- 2 Open the top cover.

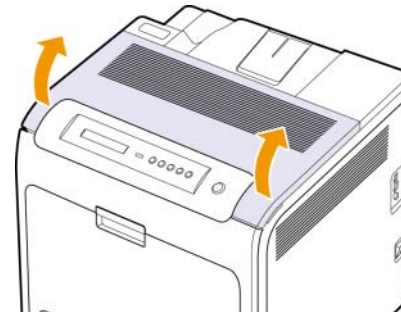

- 3 Open the inner cover using the handle on it.

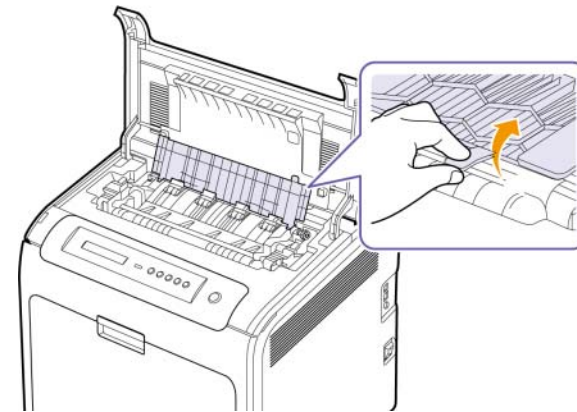

Caution

Do not touch the fuser inside the inner cover. It is hot and could cause burns! The fuser's operating temperature is 180°C (356°F). Take care when removing paper from the machine.

- 4 Pull up the paper jam lever to loose the fusing part of the fuser unit and carefully take the jammed paper out of the machine.

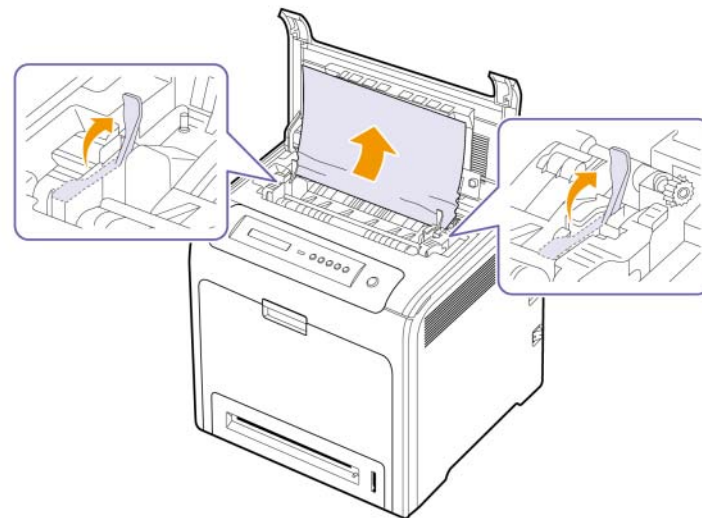

- 5 Press down the paper jam lever to fasten the fusing part.
- 6 Close the inner cover.
- 7 After removing the jammed paper, check for paper which may be jammed in other parts of the machine.
- 8 Close the top cover. Make sure that it is securely latched.



Caution

If the top cover is not completely closed, the machine will not operate.

In the optional tray

If paper is jammed in the optional tray, follow the next steps to release the jammed paper.

- 1 Pull the optional tray open. After you pull it all the way out, lift up the front part of the tray slightly to release the tray from the machine.



- 2 If you see the jammed paper, remove the paper from the machine by gently pulling it straight out as shown below.



- 3 Slide the tray back into the machine and close the two jam covers.
- 4 Open the front cover.

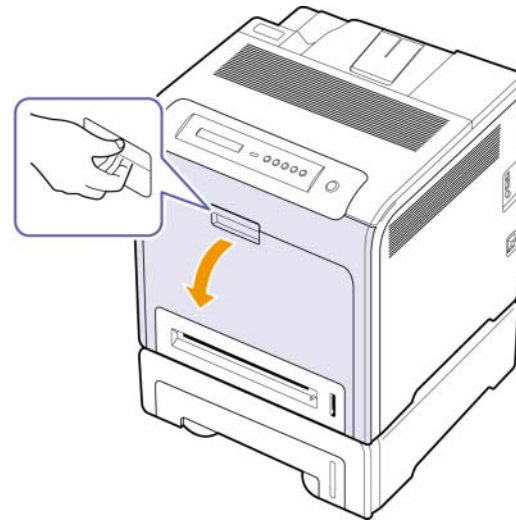

- 5 Pull the jammed paper out in the direction shown. To avoid tearing the paper, pull it out gently and slowly.

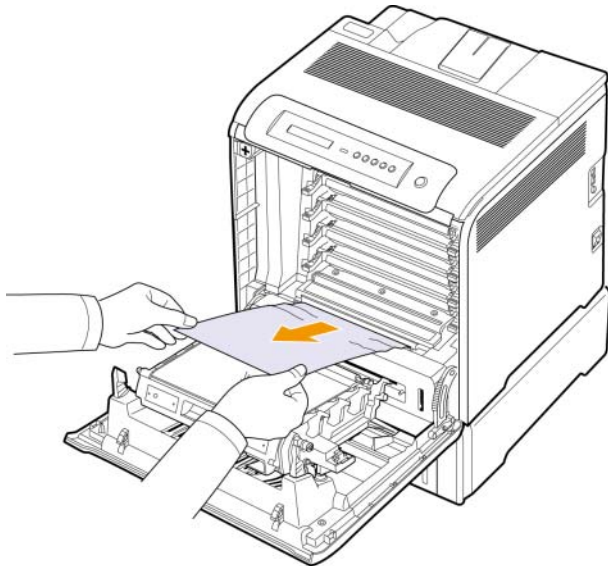

- 6 Close the front cover firmly. The machine will resume printing.



Caution

If the front cover is not completely closed, the machine will not operate.

Understanding display messages

Messages appear on the Smart Panel program window or on the control panel display to indicate machine status or errors. Refer to the tables below to understand the messages meaning to correct the problem, if necessary. Messages and their explanations are listed in alphabetical order.



Note

- When you call for service, it is very convenient to provide the service representative with the contents of the display message.
- If the message is not in the table, cycle the power and try the printing job again. If the problem persists, call for service.
- Some messages may not appear in the display depending on options or models. If so, it is not applicable to your machine.

* xxx indicates the media type.

* yyy indicates the tray.

Message	Explanation	Solution
[yyy] Cassette Out	The tray cassette is not inserted, or not properly closed.	To close the tray, lower the rear edge, align it with the slot, and slide it into the printer.
[yyy] Paper Empty	There is no paper in the tray.	Load paper in the tray. (Page 4.4)
ADC Not Confirm Error	There is a problem in the ADC (Analog to Digital Converter) of your machine.	Cycle power. If the problem persists, contact the service representatives.
ADC Slope Error Cycle Power	The temperature slope for ADC (Analog to Digital Converter) detects the value out of the normal range.	Cycle power. If the problem persists, contact the service representatives.
Adjusting... Registration	The machine is adjusting the color registration.	Wait a few minutes.
Deve Motor Locked	There is a problem with the development motor to machines which moves the toner supply device.	Cycle power. If the problem persists, contact the service representatives.
Door Open/Check Transfer Belt	The front cover or the top cover is not securely latched.	Close the cover until it locks into place.

Message	Explanation	Solution
Duplex Jam 0 Check Inside	Paper has jammed during duplex printing. This is applicable only to machines with this feature.	Clear the jam. (Page 7.1)
Fuser Fan Locked	There is a problem with the fan for the fuser unit.	Cycle power. If the problem persists, contact the service representatives.
Install Transfer Belt	The transfer belt is not installed.	Install a Samsung-genuine transfer belt. (Page 8.1, Page 6.6)
Install Toner ▼	The toner cartridge is installed improperly, or not installed.	Reinstall the toner cartridge two or three times to confirm it is seated properly. If the problem persists, the toner cartridge is not being detected. Contact the service representatives.
Invalid Toner ▼	The toner cartridge which the arrow indicates is not suitable for your machine.	Install the corresponding toner cartridge with a Samsung-genuine cartridge. (Page 6.4)
Invalid Transfer Belt	The transfer belt is not suitable for your machine.	Reinstall the transfer belt two or three times to confirm it is seated properly. Make sure that the transfer belt is Samsung-genuine product. If the problem persists, contact the service representatives.
IP Conflict	The network IP address you have set is being used by someone else.	Check the IP address and reset it if necessary. (Page 3.2)
Load Manually Press Stop Key	The multi-purpose tray is empty in manual feed mode.	Load paper in the multi-purpose tray. (Page 4.6)
Load [xxx] In [yyy]	There is no corresponding paper in the corresponding tray.	Load corresponding paper in the corresponding tray. (Page 4.4)

Message	Explanation	Solution
Low Heat Error Cycle Power	The fuser unit is low-heated.	Cycle power. If the problem persists, contact the service representatives.
OPC Motor Locked	There is a problem with the main motor for the machine.	Cycle power. If the problem persists, contact the service representatives.
MP Tray Paper Jam 0	Paper has jammed in the multi-purpose tray.	Clear the jam. (Page 7.3)
New Fuser Error	The problem has occurred in the newly installed fuser unit.	Cycle power. If the problem persists, contact the service representatives.
Non SAMSUNG Toner ▼	The toner cartridge which the arrow indicates is not a Samsung-genuine cartridge. ◀ Stop ▶	You can select either Stop or Continue with the left/right arrow. If you select Stop by pressing OK on the control panel, the machine stops printing. If you select Continue , the machine keeps printing, but the quality cannot be guaranteed. If you do not select any, the machine will work as if Stop is selected. Replace the corresponding toner cartridge with a Samsung-genuine cartridge. (Page 6.4)
Paper Jam 0 Open/Close Door	Paper has jammed in the paper feed area and inside the machine.	Clear the jam. (Page 7.1)
Paper Jam 1 Open/Close Door	Paper has jammed inside the machine.	Clear the jam. (Page 7.1)
Paper Jam 2 Check Inside	Special print media has jammed in the paper exit area.	Clear the jam. (Page 7.5)

Message	Explanation	Solution
Replace Fuser	The life of the fuser unit is expired.	Replace the fuser unit with a new one. Contact the service representatives.
Replace Fuser Soon	The life of the fuser unit will be expired soon.	Replace the fuser unit with a new one. Contact the service representatives.
Replace Transfer Belt	The life of the transfer belt is expired.	Replace the paper transfer belt with a new one. Contact the service representatives.
Replace Transfer Belt Soon	The life of the transfer belt will be expired soon.	Replace the transfer belt with a new one. Contact the service representatives.
Replace [yyy] Pick-Roller	The life of the tray pick-up roller has expired.	Replace the pick-up roller with a new one. Contact the service representatives.
Self Diagnostics LSU	The LSU (Laser Scanning Unit) in your machine is checking problems detected.	Wait a few minutes.
Self Diagnostics Temperature	The engine in your machine is checking problems detected.	Wait a few minutes.
Sleeping...	The machine is in the power save mode.	When data is received, it switches to on-line automatically.
System Fan Locked	There is a problem with the main fan for the machine.	Cycle power. If the problem persists, contact the service representatives.

Message	Explanation	Solution
Toner Empty ▼	The toner cartridge which the arrow indicates has run out. ◀ Stop ▶ Note If the black toner cartridge is empty, Black Only message does not appear.	You can select the option among Stop , Continue or Black Only with the left/right arrow. If you select Stop by pressing OK on the control panel, the machine stops printing. If you select Continue , the machine keeps printing, but the quality cannot be guaranteed. If you select Black Only , the machine prints the data in black. In this case, the mono printing feature is preset in the printer properties. If you do not select any, the machine will work as Stop is selected. Replace the corresponding toner cartridge with a Samsung-genuine cartridge. (Page 6.4)
Toner Exhausted ▼	The lifespan of the toner cartridge which the arrow indicates is reached.	This message appears when the toner is completely empty, and your machine stops printing. Replace the corresponding toner cartridge with a Samsung-genuine cartridge. (Page 6.4)
Toner Low ▼	The toner cartridge which the arrow indicates is almost empty.	Take out the corresponding toner cartridge and thoroughly shake it. By doing this, you can temporarily reestablish printing operations. (Page 6.3)
Tray 2 Paper Jam 0	Paper has jammed in the optional tray.	Clear the jam. (Page 7.6)

Solving other problems

The following chart lists some conditions that may occur and the recommended solutions. Follow the suggested solutions until the problem is corrected. If the problem persists, call for service.

Paper feeding problems

Condition	Suggested solutions
Paper is jammed during printing.	Clear the paper jam. (See "Clearing paper jams" on page 7.1.)
Paper sticks together.	<ul style="list-style-type: none"> • Ensure there is not too much paper in the tray. The tray can hold up to 250 sheets of paper, depending on the thickness of the paper. • Make sure that you are using the correct type of paper. (See "Specifications on print media" on page 4.2.) • Remove paper from the tray and flex or fan the paper. • Humid conditions may cause some paper to stick together.
Multiple sheets of paper do not feed.	<ul style="list-style-type: none"> • Different types of paper may be stacked in the tray. Load paper of only one type, size, and weight. • If multiple sheets have caused a paper jam, clear the paper jam. (See "Clearing paper jams" on page 7.1.)
Paper does not feed into the machine.	<ul style="list-style-type: none"> • Paper has not been loaded correctly. Remove paper from the tray and reload it correctly. • There is too much paper in the tray. Remove excess paper from the tray. • The paper is too thick. Use only paper that meets the specifications required by the machine. (See "Specifications on print media" on page 4.2.) • Remove any obstructions from inside the machine.
The paper keeps jamming.	<ul style="list-style-type: none"> • There is too much paper in the tray. Remove excess paper from the tray. If you are printing on special materials, use the multi-purpose tray. • An incorrect type of paper is being used. Use only paper that meets the specifications required by the machine. (See "Specifications on print media" on page 4.2.) • There may be debris inside the machine. Open the front cover and remove the debris.
Envelopes skew or fail to feed correctly.	Ensure the paper guides are against both sides of the envelopes.

Printing problems

Condition	Possible cause	Suggested solutions
The machine does not print.	The machine is not receiving power.	Check the power cord connections. Check the power switch and the power source.
	The machine is not selected as the default printer.	Select a machine name as your default printer in your Windows.
	Check the machine for the following: <ul style="list-style-type: none"> • The cover is not closed. Close the cover. • Paper is jammed. Clear the paper jam. (See "Clearing paper jams" on page 7.1.) • No paper is loaded. Load paper. (See "Loading paper" on page 4.4.) • The toner cartridge is not installed. Install the toner cartridge. If a system error occurs, contact your service representative.	
	The connection cable between the computer and the machine is not connected properly.	Disconnect the printer cable and reconnect it.
	The connection cable between the computer and the machine is defective.	If possible, attach the cable to another computer that is working properly and print a job. You can also try using a different printer cable.
	The port setting is incorrect.	Check the Windows printer setting to make sure that the print job is sent to the correct port. If the computer has more than one port, make sure that the machine is attached to the correct one.
	The machine may be configured incorrectly.	Check the printer properties to ensure that all of the print settings are correct.
	The printer driver may be incorrectly installed.	Repair the printer software. See Software section.
	The machine is malfunctioning.	Check the display message on the control panel to see if the machine is indicating a system error. Contact a service representative.



Condition	Possible cause	Suggested solutions
The print quality is not good or not clear.	The environment is in the low temperature and low humidity. This environment can cause the unclear print quality.	Go to printer properties, and change the printer language in Printer tab.
The black color of the print-out is not vivid black or fades.	When the black toner cartridge is empty, the machine makes the black color compounded from the rest three color toner cartridges. This black-like color may not be exactly the same as the true black. Also, if the rest three color toner cartridges are getting empty, the color may fade.	Replace the black toner cartridge.
The machine selects print materials from the wrong paper source.	The paper option that was selected in the machine properties may be incorrect.	For many software applications, the paper source selection is found under the Paper tab within the printer properties. Select the correct paper source. See the printer driver help screen.
A print job is extremely slow.	The job may be very complex.	Reduce the complexity of the page or try adjusting the print quality settings such as adjusting the resolution.
Half the page is blank.	The page orientation setting may be incorrect.	Change the page orientation in your application. See the printer driver help screen.
	The paper size and the paper size settings do not match.	Ensure the paper size in the printer driver settings matches the paper in the tray. Or, ensure the paper size in the printer driver settings matches the paper selection in the software application settings you use.

Condition	Possible cause	Suggested solutions
The machine prints, but the text is wrong, garbled, or incomplete.	The printer cable is loose or defective.	Disconnect the printer cable and reconnect. Try a print job that you have already printed successfully. If possible, attach the cable and the machine to another computer and try a print job that you know works. Finally, try a new printer cable.
	The wrong printer driver was selected.	Check the application's printer selection menu to ensure that your machine is selected.
	The software application is malfunctioning.	Try printing a job from another application.
	The operating system is malfunctioning.	Exit Windows and reboot the computer. Turn the machine off and then back on again.
	If you are under the DOS environment, the font setting for your machine may be set incorrectly.	Change the font setting. See 3.5
Pages print, but they are blank.	The toner cartridge is defective or out of toner.	Redistribute the toner, if necessary. If necessary, replace the toner cartridge.
	The file may have blank pages.	Check the file to ensure that it does not contain blank pages.
	Some parts, such as the controller or the board, may be defective.	Contact a service representative.
PDF file does not print correctly—some parts are missing in the graphics, text or illustrations.	Incompatibility between the PDF file and the Acrobat products.	Printing the PDF file as an image may enable the file to print. Turn on Print As Image from the Acrobat printing options. Note: It will take longer to print when you print a PDF file as an image.

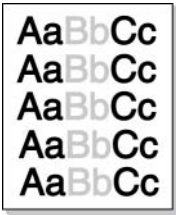

Condition	Possible cause	Suggested solutions
The print quality of photos is not good. Images are not clear.	The resolution is set to Normal .	Change the resolution to Best in the machine properties window and then try printing again.
	The resolution of the photo is very low.	Reduce the photo size. If you increase the photo size in the software application, the resolution will be reduced.
Your machine has an odd smell during initial use.	The oil used to protect the fuser is evaporating.	After printing about 100 color pages, there will be no more smell. It is a temporary issue.
Before printing, the machine emits vapor near the output tray.	Using damp paper can cause vapor during printing.	This is not a problem. Just keep printing.

Printing quality problems

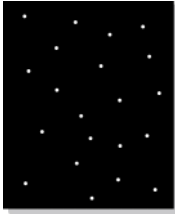
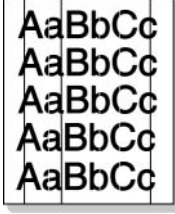
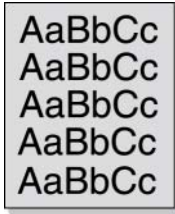
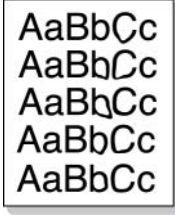

If the inside of the machine is dirty or paper has been loaded improperly, you may notice a reduction in print quality. See the table below to clear the problem.

Condition	Suggested solutions
<p>Light or faded print</p> 	<p>If a vertical white streak or faded area appears on the page:</p> <ul style="list-style-type: none"> The toner supply is low. You may be able to temporarily extend the toner cartridge life. If this does not improve the print quality, install a new toner cartridge. The paper may not meet paper specifications; for example, the paper may be too moist or rough. (See "Specifications on print media" on page 4.2.) If the entire page is light, the print resolution setting is too low or the toner save mode is on. Adjust the print resolution and turn the toner save mode off. See the help screen of the printer driver and refer to Software section, respectively. A combination of faded or smeared defects may indicate that the toner cartridge needs cleaning. Contact a service representative. The surface of the LSU part inside the machine may be dirty. Clean the LSU, contact a service representative.
<p>Toner specks</p> 	<ul style="list-style-type: none"> The paper may not meet specifications; for example, the paper may be too moist or rough. (See "Specifications on print media" on page 4.2.) The paper transfer belt may be dirty. Clean the inside of your machine. Contact a service representative. The paper path may need cleaning. Contact a service representative.
<p>Dropouts</p> 	<p>If faded areas, generally rounded, occur randomly on the page:</p> <ul style="list-style-type: none"> A single sheet of paper may be defective. Try reprinting the job. The moisture content of the paper is uneven or the paper has moist spots on its surface. Try a different brand of paper. (See "Specifications on print media" on page 4.2.) The paper lot is bad. The manufacturing processes can cause some areas to reject toner. Try a different kind or brand of paper. If these steps do not correct the problem, contact a service representative.

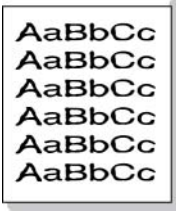
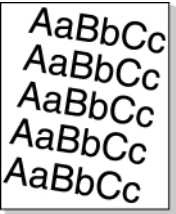
Condition	Suggested solutions
White Spots 	<p>White spots appear on the page:</p> <ul style="list-style-type: none"> The paper is too rough and a lot of dirt from the paper falls to the inner devices within the machine, which means the transfer belt may be dirty. Clean the inside of your machine. Contact a service representative. The paper path may need cleaning. Contact a service representative.
Vertical lines 	<p>If black vertical streaks appear on the page:</p> <ul style="list-style-type: none"> The toner cartridge has probably been scratched. Remove the toner cartridge and install a new one. <p>If white vertical streaks appear on the page:</p> <ul style="list-style-type: none"> Clean the inside of the machine. Contact a service representative to clean the inside of the machine.
Color or Black background 	<p>If the amount of background shading becomes unacceptable:</p> <ul style="list-style-type: none"> Change to a lighter weight paper. (See "Specifications on print media" on page 4.2.) Check the environmental conditions: very dry conditions (low humidity) or a high level of humidity (higher than 80% RH) can increase the amount of background shading. Remove the old toner cartridge, and then install a new one. (See "Replacing the toner cartridge" on page 6.4.)
Toner smear 	<ul style="list-style-type: none"> Clean the inside of the machine. Contact a service representative to clean the inside of the machine. Check the paper type and quality. (See "Specifications on print media" on page 4.2.) Remove the paper transfer belt, and then install a new one. (See "Replacing the toner cartridge" on page 6.4.)

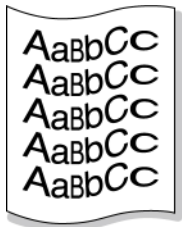
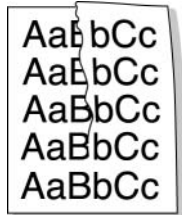
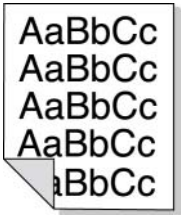
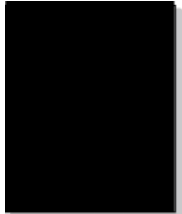
Condition	Suggested solutions
Vertical repetitive defects 	<p>If marks repeatedly appear on the printed side of the page at even intervals:</p> <ul style="list-style-type: none"> Clean the inside of the machine. Contact a service representative to clean the inside of the machine. After cleaning the inside of the machine, if you still have the same problems, install a new toner cartridge of the problem color. See "Replacing the toner cartridge" on page 6.4. Parts of the machine may have toner on them. If the defects occur on the back of the page, the problem will likely correct itself after a few more pages. The fusing assembly may be damaged. Contact a service representative.
Background scatter 	<p>Background scatter results from bits of toner randomly distributed on the printed page.</p> <ul style="list-style-type: none"> The paper may be too damp. Try printing with a different batch of paper. Do not open packages of paper until necessary so that the paper does not absorb too much moisture. If background scatter occurs on an envelope, change the printing layout to avoid printing over areas that have overlapping seams on the reverse side. Printing on seams can cause problems. If background scatter covers the entire surface area of a printed page, adjust the print resolution through your software application or in printer properties.
Misformed characters 	<ul style="list-style-type: none"> If characters are improperly formed and producing hollow images, the paper stock may be too slick. Try different paper. (See "Specifications on print media" on page 4.2.)
Page skew 	<ul style="list-style-type: none"> Ensure that the paper is loaded properly. Check the paper type and quality. (See "Specifications on print media" on page 4.2.) Ensure that the paper or other material is loaded correctly and the guides are not too tight or too loose against the paper stack.

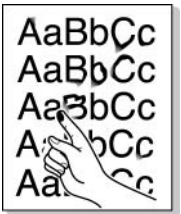
Condition	Suggested solutions
Curl or wave 	<ul style="list-style-type: none"> • Ensure that the paper is loaded properly. • Check the paper type and quality. Both high temperature and humidity can cause paper curl. (See "Specifications on print media" on page 4.2.) • Turn the stack of paper over in the tray. Also try rotating the paper 180° in the tray.
Wrinkles or creases 	<ul style="list-style-type: none"> • Ensure that the paper is loaded properly. • Check the paper type and quality. (See "Specifications on print media" on page 4.2.) • Turn the stack of paper over in the tray. Also try rotating the paper 180° in the tray.
Back of printouts are dirty 	<p>Check for leaking toner. Clean the inside of the machine. Contact a service representative.</p>
Black pages 	<ul style="list-style-type: none"> • The toner cartridge may not be installed properly. Remove the cartridge and reinsert it. • The toner cartridge may be defective and need replacing. Remove the toner cartridge and install a new one. (See "Replacing the toner cartridge" on page 6.4.) • The machine may require repair. Contact a service representative.

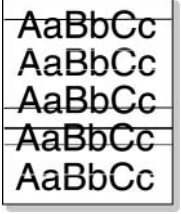
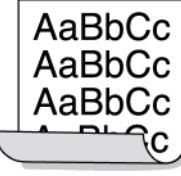
Condition	Suggested solutions
Loose toner 	<ul style="list-style-type: none"> • Clean the inside of the machine. Contact a service representative to clean the inside of the machine. After cleaning the inside of the machine, if you still have the same problems, contact a service representative. • Check the paper type and quality. (See "Specifications on print media" on page 4.2.) • Remove the toner cartridge, and then install a new one. (See "Replacing the toner cartridge" on page 6.4.) • If the problem persists, the machine may require repair. Contact a service representative.
Character Voids 	<p>Character voids are white areas within parts of characters that should be solid black:</p> <ul style="list-style-type: none"> • You may be printing on the wrong surface of the paper. Remove the paper and turn it around. • The paper may not meet paper specifications. (See "Specifications on print media" on page 4.2.)
Horizontal stripes 	<p>If horizontally aligned black streaks or smears appear:</p> <ul style="list-style-type: none"> • The toner cartridge may be installed improperly. Remove the cartridge and reinsert it. • The toner cartridge may be defective. Remove the toner cartridge and install a new one. (See "Replacing the toner cartridge" on page 6.4.) • If the problem persists, the machine may require repair. Contact a service representative.
Curl 	<p>If the printed paper is curled or paper does not feed into the machine:</p> <ul style="list-style-type: none"> • Turn the stack of paper over in the tray. Also try rotating the paper 180° in the tray.

Condition	Suggested solutions
An unknown image repetitively appears on the next few sheets or loose toner, light print, or contamination occurs.	You machine is probably being used at an altitude of 1,000 m (3,281 ft) or above. The high altitude may affect the print quality from loose toner or light imaging. You can set this option through Printer Settings Utility or the Printer Tab in printer driver's properties. See "Altitude Setting after Software Installation" on page 3.4.

Common Windows problems

Condition	Suggested solutions
"File in Use" message appears during installation.	Exit all software applications. Remove all software from the StartUp Group, then restart Windows. Reinstall the printer driver.
"Error Writing to LPTx" message appears.	<ul style="list-style-type: none"> • Ensure that the cables are connected correctly and the machine is on. • If bi-directional communication is not turned on in the driver, it will also cause this message.
"General Protection Fault", "Exception OE", "Spool32", or "Illegal Operation" messages appear.	Close all other applications, reboot Windows and try printing again.
"Fail To Print", "A machine timeout error occurred." messages appear.	These messages may appear during printing. Just keep waiting until the machine finishes printing. If the message appears in standby mode or after printing has been completed, check the connection and/or whether an error has occurred.



Note

Refer to Microsoft Windows 2000/XP/2003/Vista User's Guide that came with your PC for further information on Windows error messages.

Common PostScript problems

The following situations are PS language specific and may occur when several printer languages are being used.



Note

To receive a printed or screen-displayed message when PostScript errors occur, open the Print Options window and click the desired selection next to the PostScript errors section.

Problem	Possible Cause	Solution
PostScript file cannot be printed.	The PostScript driver may not be installed correctly.	<ul style="list-style-type: none"> • Install the PostScript driver, referring to Software section. • Print a configuration page and verify that the PS version is available for printing. • If the problem persists, contact a service representative.
"Limit Check Error" message appears.	The print job was too complex.	You might need to reduce the complexity of the page or install more memory.
A PostScript error page prints.	The print job may not be PostScript.	Make sure that the print job is a PostScript job. Check to see whether the software application expected a setup or PostScript header file to be sent to the machine.
The optional tray is not selected in the driver.	The printer driver has not been configured to recognize the optional tray.	Open the PostScript driver properties, select the Device Settings tab, and set the Tray option of the Installable Options section to Installed .
When printing a document in Macintosh with Acrobat Reader 6.0 or higher, colors print incorrectly.	The resolution setting in the printer driver may not be matched with the one in Acrobat Reader.	Make sure that the resolution setting in your printer driver matches the one in Acrobat Reader.

Common Linux problems

Problem	Possible Cause and Solution
The machine does not print.	<ul style="list-style-type: none"> • Check if the printer driver is installed in your system. Open the Unified Driver configuration tool and switch to the Printers tab in the Printers configuration window to look at the list of available machines. Make sure that your machine is displayed on the list. If not, use the Add new printer wizard to set up your device. • Check if the machine has started. Open Printers configuration and select your machine on the machines list. Look at the description in the Selected printer pane. If its status contains a "(stopped)" string, click Start. After that, normal operation of the machine should be restored. The "stopped" status might have been activated when problems in printing occurred. • Check if your application has special print options such as "-oraw". If "-oraw" is specified in the command line parameter, then remove it to print properly. For Gimp front-end, select "print" -> "Setup printer" and edit the command line parameter in the command item. • The CUPS (Common Unix Printing System) version distributed with SuSE Linux 9.2 (cups-1.1.21) has a problem with ipp (Internet Printing Protocol) printing. Use the socket printing instead of ipp or install a later version of CUPS (cups-1.1.22 or higher).
Some color images come out in unexpected color.	This is a known bug in Ghostscript (until GNU Ghostscript version 7.xx) when the base color space of the document is indexed RGB color space and it is converted through CIE color space. Because Postscript uses CIE color space for Color Matching System, you should upgrade Ghostscript on your system to at least GNU Ghostscript version 8.xx or later. You can find recent Ghostscript versions at www.ghostscript.com .

Problem	Possible Cause and Solution
The machine does not print whole pages and its output is half-page printed.	It is a known problem that occurs when a color machine is used on version 8.51 or earlier of Ghostscript, 64-bit Linux OS, and reported to bugs.ghostscript.com as Ghostscript Bug 688252. The problem is solved in AFPL Ghostscript v. 8.52 or above. Download the latest version of AFPL Ghostscript from http://sourceforge.net/projects/ghostscript/ and install it to solve this problem.
I encounter error "Cannot open port device file" when printing a document.	Avoid changing print job parameters (via LPR GUI, for example) while a print job is in progress. Known versions of CUPS server cut off the print jobs whenever print options are changed and then try to restart the job from the beginning. Since Unified Linux Driver locks the port while printing, the abrupt termination of the driver keeps the port locked and therefore unavailable for subsequent print jobs. If this situation occurs, try to release the port.

Common Macintosh problems

Problem	Suggested solutions
PDF file does not print correctly-some parts are missing in the graphics, text or illustrations.	Incompatibility between the PDF file and the Acrobat products. Printing the PDF file as an image may enable the file to print. Turn on Print As Image from the Acrobat printing options. Note: It will take longer to print when you print a PDF file as an image.
The document has printed, but the print job has not disappeared from the spooler in Mac OS 10.3.2.	Update your Mac OS to OS 10.3.3. or higher.
Some letters are not displayed normally during the cover page printing.	This problem is caused because the Mac OS cannot find the font during the cover page printing. English alphabet and numbers are displayed normally on the cover page.
Some fonts are not printed properly in the Adobe Illustrator program.	Those fonts may not supported by your machine. Start the Adobe Illustrator program, click File > Print > Illustrator tab. Then, check Force Fonts to Download , and try again.

8 Ordering supplies and accessories

This chapter provides information on purchasing cartridges and accessories available for your machine.

This chapter includes:

- **Supplies**
- **Accessories**
- **How to purchase**

Supplies

When the toner runs out, you can order the following type of toner cartridge for your machine:

Type	Average yield ^a	Part number
High yield toner cartridge	Approx. 5,500 (Black), 5,000 (Color)	CLP-K660B (Black) CLP-C660B (Cyan) CLP-M660B (Magenta) CLP-Y660B (Yellow)
Standard yield toner cartridge	Approx. 2,500 (Black), 2,000 (Color)	CLP-K660A (Black) CLP-C660A (Cyan) CLP-M660A (Magenta) CLP-Y660A (Yellow)
Paper transfer belt	When the transfer belt has worn out with abrasion, you need to change it. By this time you may be notified with the transfer belt-related message on the display.	CLP-T660B

a. Declared yield value in accordance with ISO/IEC 19798.



Caution

When you purchase a new toner cartridge or supplies, you must purchase them in the same country you have purchased your machine. Otherwise, the toner cartridge or supplies will be incompatible with your machine since the configuration of the toner cartridge or supplies vary depending on the countries.

Accessories

You can purchase and install accessories to enhance your machine's performance and capacity.

Accessory	Description	Part number
Memory module	Extends your machine's memory capacity.	<ul style="list-style-type: none"> • CLP-660 series CLP-MEM101: 128 MB CLP-MEM102: 256 MB CLP-MEM103: 512 MB • CLP-610 series CLP-MEM201: 128 MB CLP-MEM202: 256 MB
Optional tray 2	If you are experiencing frequent paper supply problems, you can attach an additional 500 sheet tray. You can print documents in various sizes and types of print materials.	CLP-S660A
Duplex unit	Enables duplex printing to save the paper consumption.	CLP-U660A Note: If you want to use the duplex feature, contact the sales point to purchase the duplex option.



Note

Your machine may have two memory slots with a factory pre-installed memory module in one slot. When you are expanding the memory capacity, you can add a memory module to the vacant memory slot, according to the table above. It is strongly recommended that you expand a memory module in vacant memory slot only, without removing a pre-installed memory module. If your machine has 128MB memory capacity and you want to add 512MB, the memory capacity expands up to 640MB.

How to purchase

To order Samsung-authorized supplies or accessories, contact your local Samsung dealer or the retailer where you purchased your machine, or visit www.samsungprinter.com and select your country/region to obtain information on calling for technical support.

9 Installing accessories

Your machine is a full-featured model that has been optimized to meet most of your printing needs. Recognizing that each user may have different requirements, however, Samsung makes several accessories available to enhance your machine's capabilities.

This chapter includes:

- **Precautions to take when installing accessories**
- **Installing a memory module**

Precautions to take when installing accessories

- **Disconnect the power cord**

Never remove the control board cover while the power is turned on.

To avoid the possibility of an electrical shock, always disconnect the power cord when installing or removing ANY internal or external accessories.

- **Discharge static electricity**

The control board and internal accessories (network interface card or memory module) are sensitive to static electricity. Before installing or removing any internal accessories, discharge static electricity from your body by touching something metal, such as the metal back plate on any device plugged into a grounded power source. If you walk around before finishing the installation, repeat this procedure to discharge any static electricity again.

Installing a memory module

Your machine has a dual in-line memory module (DIMM). Use this memory module slot to install additional memory.

The machine has two memory slots with a factory pre-installed memory module in one slot. When you are expanding the memory capacity, you can add a memory module to the vacant memory slot. It is strongly recommended that you expand a memory module in vacant memory slot only without removing the pre-installed memory module. If your machine has 128 MB memory capacity and you want to add 512 MB, the memory capacity expands up to 640 MB.

Order information is provided for optional memory module. (See "Accessories" on page 8.1.)

- 1 Turn the machine off and unplug all cables from the machine.

- 2 Open the control board cover. Release the screw, then lift up the cover slightly and pull the cover to the right.

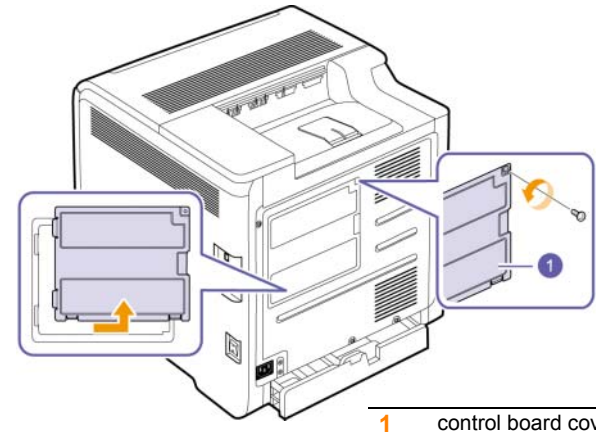

Note

If you want to remove an existing memory module, push the two latches at the ends of the module outward.

- 3 Take out a new memory module from the plastic bag.
- 4 Holding the memory module by the edges, align the memory module on the slot at about a 30-degree tilt. Make sure that the notches of the module and the grooves on the slot fit each other.

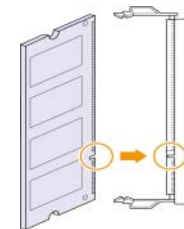

Note

The notches and grooves illustrated above may not match those on an actual memory module and its slot.

- 5 Press the memory module into the slot with care until you hear a 'click'.

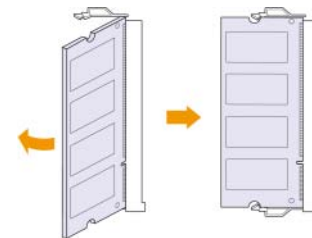

Caution

Do not press the memory module strongly or the module may be damaged. If the module does not seem to fit into the slot properly, carefully try the previous procedure again.

- 6 Replace the control board cover and fasten the cover with the screw.

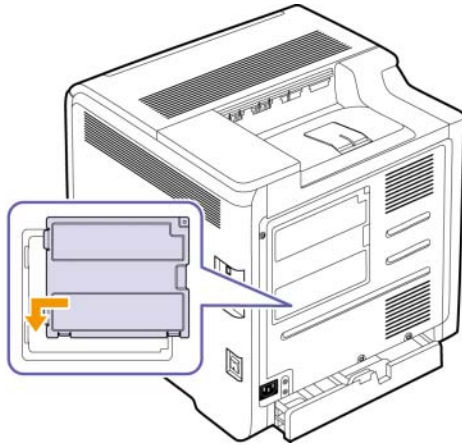

- 7 Reconnect the power cord and printer cable, and turn the machine on.



Note

To release the memory module, pull the two tabs on the sides of the slot outwards, then the module springs out.

Activating the added memory in the PS printer properties

After installing the memory module, you need to select it in the printer properties of the PostScript printer driver in order to use it. This activation is needed only the machine compatible with the PostScript driver.

- 1 Make sure that the PostScript printer driver is installed on your computer. For details about installing the PS printer driver, see Software section.
- 2 Click the Windows **Start** menu.
- 3 For Windows 2000, select **Settings** and then **Printers**.
For Windows XP/2003, select **Printers and Faxes**.
For Windows Vista, select **Control Panel > Hardware and Sound > Printers**.
- 4 Select the **Samsung CLP-6xx Series PS** printer.
- 5 Click the right mouse button on the printer icon and select **Properties**.
- 6 Select **Device Settings**.
- 7 Select the amount of memory you installed from **Printer Memory** in the **Installable Options** section.
- 8 Click **OK**.

10 Specifications

This chapter includes:

- **CLP-610 Series**
- **CLP-660 Series**



Note

The numbers herein is subject to change according to its install environment.

CLP-610 Series

Item	Specifications and Description	
Printing speed ^a	Up to 20 ppm ^b (A4), 21 ppm (Letter)	
Duplex printing speed	Up to 9.86 ipm ^c (A4, Letter)	
Printing resolution	Max. 2,400 x 600 dpi effective output	
Warm-up time	Less than 40 seconds	
First print out time	20 seconds (from Ready mode)	
Consumables life	Standard yield toner cartridge ^d	<ul style="list-style-type: none"> • Average continuous colored cartridge yield: Approx. 2,500 standard pages (Black)^e • Average continuous colored cartridge yield: Approx. 2,000 standard pages (Yellow/Magenta/Cyan)^e
	High yield toner cartridge ^d	<ul style="list-style-type: none"> • Average continuous colored cartridge yield: Approx. 5,500 standard pages (Black) • Average continuous colored cartridge yield: Approx. 5,000 standard pages (Yellow/Magenta/Cyan)
	Paper transfer belt	<ul style="list-style-type: none"> • 50,000 pages (Black, A4, Letter) • 50,000 pages (Yellow/Magenta/Cyan, A4, Letter)
Noise level ^f	<ul style="list-style-type: none"> • Less than 29 dBA (from Ready mode) • Less than 51 dBA (from Printing mode) 	

Item	Specifications and Description	
Power rating	AC 110 - 127 V or AC 220 - 240 V See the Rating label on the machine for the correct voltage, frequency (hertz) and type of current for your machine.	
Power consumption	<ul style="list-style-type: none"> • Printing mode: less than 550 W • Ready mode: less than 120 W • Power save mode: less than 17 W 	
External dimension (W x D x H)	432 x 432 x 424 mm (17 x 17 x 16.7 inches) (without optional tray)	
Weight	25.6 Kg (56.44 lbs) (including consumables)	
Package weight	Paper	3.8 kg (8.38 lbs)
	Plastic	1.1 kg (2.43 lbs)
Operating environment	Operating Temperature	10 to 32.5 °C (50 to 90 °F)
	Recommended Temperature	15 to 30 °C (59 to 86 °F)
	Operating Humidity	20 to 80% RH
	Recommended Humidity	20 to 80% RH
Memory	128 MB (expandable up to 384 MB) DDR2 only, 2 slots	
Fonts	SPL-C	OS Fonts
	PCL6	1 bitmap 45 scalable
Interface	USB 2.0 Ethernet 10/100 Base TX	
OS compatibility & driver	Windows 2000/2003/ XP/ Vista	SPL-C (Samsung Printer Language Color) driver, PCL6 driver
	Various Linux OS	SPL-C driver
	Mac 10.3 ~ 10.5	SPL-C driver
Printer language	PCL5c, PCL6, SPL-C	
Option	500 sheet tray	
Duty cycle	Up to 65,000 pages (Monthly)	
Fusing temperature	180 °C (356 °F)	

- a. Printing speed: it will be affected by operating system used, computing performance, application software, connecting method, media type, media size, and job complexity.
- b. ppm: page per minute.
- c. ipm: image per minute.
- d. Declared yield value in accordance with ISO/IEC 19798.
- e. It varies depending on the product configuration.
- f. Noise Level: sound pressure level, ISO 7779.

CLP-660 Series



Note

The symbol * denotes an optional feature depending on machines.

Item	Specifications and Description	
Printing speed ^a	Up to 24 ppm ^b (A4), 25 ppm (Letter)	
Duplex printing speed*	Up to 11.8 ipm ^c (A4, Letter)	
Printing resolution	Max. 2,400 x 600 dpi effective output	
Warm-up time	Less than 30 seconds	
First print out time	14 seconds (from Ready mode)	
Consumables life	Standard yield toner cartridge ^d	<ul style="list-style-type: none"> Average continuous colored cartridge yield: Approx. 2,500 standard pages (Black)^e Average continuous colored cartridge yield: Approx. 2,000 standard pages (Yellow/Magenta/Cyan)^e
	High yield toner cartridge	<ul style="list-style-type: none"> Average continuous colored cartridge yield: Approx. 5,500 standard pages (Black) Average continuous colored cartridge yield: Approx. 5,000 standard pages (Yellow/Magenta/Cyan)
	Paper transfer belt	<ul style="list-style-type: none"> 50,000 pages (Black, A4, Letter) 50,000 pages (Yellow/Magenta/Cyan, A4, Letter)
Noise level ^f	<ul style="list-style-type: none"> Less than 29 dBA (from Ready mode) Less than 53 dBA (from Printing mode) 	

Item	Specifications and Description	
Power rating	AC 110 - 127 V or AC 220 - 240 V See the Rating label on the machine for the correct voltage, frequency (hertz) and type of current for your machine.	
Power consumption	<ul style="list-style-type: none"> Printing mode: less than 700 W Ready mode: less than 120 W Power save mode: less than 17 W 	
External dimension (W x D x H)	432 x 432 x 424 mm (17 x 17 x 16.7 inches) (without optional tray)	
Weight	25.6 Kg (55.44 lbs) (including consumables)	
Package weight	Paper	3.8 kg (8.38 lbs)
	Plastic	1.1 kg (2.43 lbs)
Operating environment	Operating Temperature	10 to 32.5 °C (50 to 90 °F)
	Recommended Temperature	15 to 30 °C (59 to 86 °F)
	Operating Humidity	20 to 80% RH
	Recommended Humidity	20 to 80% RH
Memory	128 MB (expandable up to 640 MB) DDR1 only, 2 slots	
Fonts	PCL6	1 bitmap 45 scalable
	PS	136
Interface	USB 2.0 Ethernet 10/100 Base TX	
OS compatibility & driver	Windows 2000/2003/ XP/ Vista	PCL6 driver, PostScript driver
	Various Linux OS	PostScript driver
	Mac 10.1 ~ 10.5	PostScript driver
Printer language	PCL5c, PCL6, PostScript 3	
Option	500 sheet tray	
Duty cycle	Up to 80,000 pages (Monthly)	
Fusing temperature	180 °C (356 °F)	

- a. Printing speed: it will be affected by operating system used, computing performance, application software, connecting method, media type, media size, and job complexity.
- b. ppm: page per minute.
- c. ipm: image per minute.
- d. Declared yield value in accordance with ISO/IEC 19798.
- e. It varies depending on the product configuration.
- f. Noise Level: sound pressure level, ISO 7779.

11 Glossary

BOOTP

It stands for Bootstrap Protocol, a network protocol used by a network client to obtain its IP address automatically. This is usually done in the bootstrap process of computers or operating systems running on them. The BOOTP servers assign the IP address from a pool of addresses to each client.

Control Panel

A control panel is a flat area where control or monitoring instruments are displayed. They are typically found in top or front of the machine.

Coverage

This is the printing term used for toner usage measurement on printing and generally used as 5% coverage. 5% coverage means that an A4 sized paper has about 5% image or text on it. So, if the paper or original has complicated images or lots of text on it, the coverage will be over 5% and at the same time, toner usage will be as much as the coverage.

Default

The first set values.

DHCP

A Dynamic Host Configuration Protocol (DHCP) is a client-server networking protocol. A DHCP server provides configuration parameters specific to the DHCP client host requesting, generally, information required by the client host to participate on an IP network.

DIMM

Dual Inline Memory Module, a small circuit board that holds memory. DIMM stores all the data within the machine like printing data, received fax data, or scanned data.

DNS

The Domain Name Server (DNS) is a system that stores information associated with domain names in a distributed database on networks.

DPI

This is the measurement of resolution which is used for printing or scanning. Generally, more dots per inch result in a higher resolution, more visible detail in the image, and a larger file size.

Duplex

This is a mechanism which automatically flips over a sheet of paper so that the machine can print (or scan) on both sides of the paper. A printer equipped with a Duplex can print double-sided.

Duty Cycle

Duty cycle is the page quantity which does not affect printer performance for a month. Generally the printer has the lifespan limitation such as pages per year. The lifespan means the average capacity of print-outs, usually within the warranty period. For example, if the duty cycle is 48,000 pages per month assuming 20 working days, a printer limits 2,400 pages a day, which is not small amount.

Ethernet

Ethernet is a frame-based computer networking technology for local area networks (LANs). It defines wiring and signaling for the physical layer, and frame formats and protocols for the media access control (MAC)/data link layer of the OSI model. It has become the most widespread LAN technology in use presently.

Fuser Unit

This is the part of a laser printer that melts the toner onto the print media. It consists of two hot rollers. After toner is transferred onto the paper, the fuser unit applies heat and pressure to ensure that the toner stays on the paper permanently, which is why paper is warm when it comes out of a laser printer.

Gateway

This is a connection between computer networks, or between a computer network and a telephone line. And it is very popular, as it is a computer or a network that allows access to another computer or network.

Grayscale

Shades of gray that represent light and dark portions of an image when color images are converted to grayscale; colors are represented by various shades of gray.

Halftone

This is an image type that simulates grayscale by varying the number of dots. Highly colored areas consist of a large number of dots, while lighter areas consist of a smaller number of dots.

Intranet

This is a private network that uses Internet Protocols, network connectivity, and possibly the public telecommunication system to securely share part of an organization's information or operations with its employees. Sometimes the term refers only to the most visible service, the internal website.

IP address

An Internet Protocol address (IP address) is a unique number that devices use in order to identify and communicate with each other on a network utilizing the Internet Protocol standard (IP).

IPM

The Images Per Minute.

ISO

The International Organization for Standardization (ISO) is an international standard-setting body composed of representatives from national standards bodies. It produces world-wide industrial and commercial standards.

LED

A light-emitting diode (LED) is a semiconductor device that indicates the status of a machine.

Print Media

Media such as papers, envelopes, labels, and transparencies which can be used on a printer, a scanner, a fax or, a copier.

OPC Drum

A mechanism that makes a virtual image for print using a laser beam emitted from a laser printer, and it is usually green or gray-colored and cylinder-shaped. An exposing unit of a drum is slowly worn away by its usage of the printer, and it should be replaced appropriately since it becomes scratched from grit in paper.

PDF

Portable Document Format (PDF) is a proprietary file format developed by Adobe Systems for representing two-dimensional documents in a device-independent and resolution-independent format.

PostScript

PostScript (PS) is a page description language and programming language used primarily in the electronic and desktop publishing areas, and that is run in an interpreter to generate an image.

PPM

Pages Per Minute. PPM shows the printer's speed, how many pages a printer can actually print per minute.

PRN file

An interface for a device driver, this allows software to interact with the device driver using standard input/output system calls, which simplifies many tasks.

Protocol

This is a convention or standard that controls or enables the connection, communication, and data transfer between two computing endpoints.

PS

See PostScript.

Resolution

The sharpness of an image, measured in dots per inch (dpi). The higher the dpi, the greater the resolution.

Subnet Mask

A bitmask used to tell how many bits in an octet(s) identify the subnetwork, and how many bits provide room for host addresses.

TCP/IP

The Transmission Control Protocol (TCP) and the Internet Protocol (IP). It is the set of communications protocols that implement the protocol stack on which the Internet and most commercial networks run.

toner cartridge

It is a kind of bottle within a machine like a printer which contains toner. Toner is a powder used in laser printers and photocopiers which forms the text and images on the printed paper. Toner can be melted by the heat of the fuser, causing it to bind to the fibers in the paper.

URL

Uniform Resource Locator (URL) is the global address of documents and resources on the Internet. The first part of the address indicates what protocol to use, the second part specifies the IP address or the domain name where the resource is located.

USB

Universal serial bus (USB) is a standard that was developed by the USB Implementers Forum, Inc., to connect computers and peripherals. Unlike the parallel port, USB is designed to concurrently connect a single computer USB port to multiple peripherals.

INDEX

B

Back 1.4

C

cleaning
 inside 6.1
 outside 6.1
control panel 1.2, 1.4

D

default settings
 loading paper 3.5
 tray setting 3.5
Display 1.4
driver
 feature 2.1
 installation 3.3

E

energy saver 3.5
error message 7.7

F

front cover 1.2
front cover handle 1.2

J

jam
 clearing paper from the tray1 7.1
 tips for avoiding paper jams 7.1

L

language 3.4
LED
 Status 1.5
Left/right arrows 1.4
Linux
 problems 7.16
 requirements 2.2

M

Macintosh
 problems 7.16
 requirements 2.2
Maintenance 6.1
 maintenance parts 6.7
 toner cartridge 6.3
memory module
 installing 9.1
 ordering 8.1
Menu 1.4
message on the display screen 7.7
multi-purpose tray 1.2
multi-purpose tray handle 1.2

N

network
 port 1.3
 requirements 3.2
 setting up 3.1

O

OK 1.4
optional tray 1.2, 8.1
ordering supplies 8.1
Output tray 1.2

P

paper
 changing the size 4.5
 clearing jam 7.1
 loading in the multi-purpose tray 4.6
 loading in the optional tray 4.4
 loading in the tray1 4.4
 paper feeding problems 7.10
 setting the paper size of the tray 4.7
PostScript
 problems 7.15
Power Save 3.5
Power Saver
 using power save mode 3.5
Power switch 1.3
print media
 guidelines 4.1
 media sizes 4.3

 selecting print media 4.1
 specification 4.2
print/report
 from the website 6.7
Printer software CD 2.1
printing 5.1
 problem solving 7.10
problems
 display message 7.7
 Linux 7.16
 Macintosh 7.16
 paper feeder 7.10
 PostScript 7.15
 printing 7.10
 printing quality 7.12
 Windows 7.15

Q

quality
 solving the printing problem 7.12

R

replacing components
 toner cartridge 6.4

S

specifications 10.1, 11.1
Status 1.4
Stop 1.4
supplied software 2.1
supplies
 checking the supplies life 6.1
 expected toner cartridge life 6.3
 ordering supplies 8.1
SyncThru Web Service 6.7

T

tray
 adjusting the width and length 4.5
 optional tray 1.2
 tray1 1.2
troubleshooting 7.1

U

USB
port 1.3

W

Windows
problems 7.15
requirements 2.2



Samsung Printer

Software section

SOFTWARE SECTION

CONTENTS

Chapter 1: **INSTALLING PRINTER SOFTWARE IN WINDOWS**

Installing Printer Software	4
Installing Software for Local Printing	4
Installing Software for Network Printing	7
Reinstalling Printer Software	10
Removing Printer Software	11
Installing mono printer driver	12

Chapter 2: **BASIC PRINTING**

Printing a Document	13
Printing to a file (PRN)	14
Printer Settings	14
Layout Tab	15
Paper Tab	15
Graphics Tab	16
Extras Tab	17
About Tab	18
Printer Tab	18
Using a Favorite Setting	18
Using Help	18

Chapter 3: **ADVANCED PRINTING**

Printing Multiple Pages on One Sheet of Paper (N-Up Printing)	19
Printing Posters	20
Printing Booklets	20
Printing on Both Sides of Paper	21
Printing a Reduced or Enlarged Document	21
Fitting Your Document to a Selected Paper Size	21

Using Watermarks	22
Using an Existing Watermark	22
Creating a Watermark	22
Editing a Watermark	22
Deleting a Watermark	22
Using Overlays	23
What is an Overlay?	23
Creating a New Page Overlay	23
Using a Page Overlay	23
Deleting a Page Overlay	23

Chapter 4: USING WINDOWS POSTSCRIPT DRIVER

Printer Settings	24
Advanced	24
Using Help	24

Chapter 5: SHARING THE PRINTER LOCALLY

Setting Up a Host Computer	25
Setting Up a Client Computer	25

Chapter 6: USING SMART PANEL

Understanding Smart Panel	26
Opening the Troubleshooting Guide	27
Using Printer Settings Utility	27
Using Onscreen Help File	27
Changing the Smart Panel Program Settings	27

Chapter 7: USING YOUR PRINTER IN LINUX

Getting Started	28
Installing the Unified Linux Driver	28
Installing the Unified Linux Driver	28
Uninstalling the Unified Linux Driver	29

Using the Unified Driver Configurator	30
Opening the Unified Driver Configurator	30
Printers Configuration	30
Ports Configuration	31
Configuring Printer Properties	31
Printing a Document	32
Printing from Applications	32
Printing Files	32

Chapter 8: **USING YOUR PRINTER WITH A MACINTOSH**

Installing Software	33
Printer driver	33
Setting Up the Printer	34
For a Network-connected	34
For a USB-connected	34
Printing	35
Printing a Document	35
Changing Printer Settings	35
Printing Multiple Pages on One Sheet of Paper	37
Duplex Printing	37

1 Installing Printer Software in Windows

This chapter includes:

- **Installing Printer Software**
- **Reinstalling Printer Software**
- **Removing Printer Software**
- **Installing mono printer driver**

NOTE: The following procedure is based on Windows XP, for other operating systems, refer to the corresponding Windows user's guide or online help.

Installing Printer Software

You can install the printer software for local printing or network printing. To install the printer software on the computer, perform the appropriate installation procedure depending on the printer in use.

A printer driver is software that lets your computer communicate with your printer. The procedure to install drivers may differ depending on the operating system you are using.

All applications should be closed on your PC before beginning installation.

Installing Software for Local Printing

A local printer is a printer directly attached to your computer using the printer cable supplied with your printer, such as a USB or parallel cable. If your printer is attached to a network, skip this step and go to "Installing Software for Network Printing" on page 7.

You can install the printer software using the typical or custom method.

NOTE: If the "New Hardware Wizard" window appears during the installation procedure, click  in the upper right corner of the box to close the window, or click **Cancel**.

Typical Installation

This is recommended for most users. All components necessary for printer operations will be installed.

- 1 Make sure that the printer is connected to your computer and powered on.
- 2 Insert the supplied CD-ROM into your CD-ROM drive. The CD-ROM should automatically run, and an installation window appears. If the installation window does not appear, click **Start** and then **Run**. Type **X:\Setup.exe**, replacing "X" with the letter which represents your drive and click **OK**. If you use Windows Vista, click **Start** → **All programs** → **Accessories** → **Run**, and type **X:\Setup.exe**. If the **AutoPlay** window appears in Windows Vista, click **Run Setup.exe** in **Install or run program** field, and click **Continue** in the **User Account Control** window.

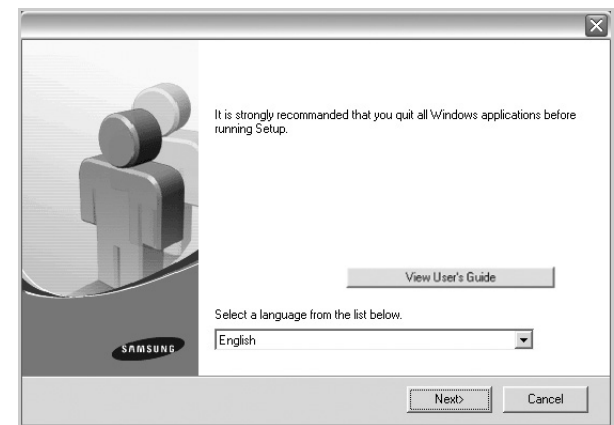

- 3 Click **Next**.
 - If necessary, select a language from the drop-down list.
- 4 Select **Typical installation for a local printer**. Click **Next**.

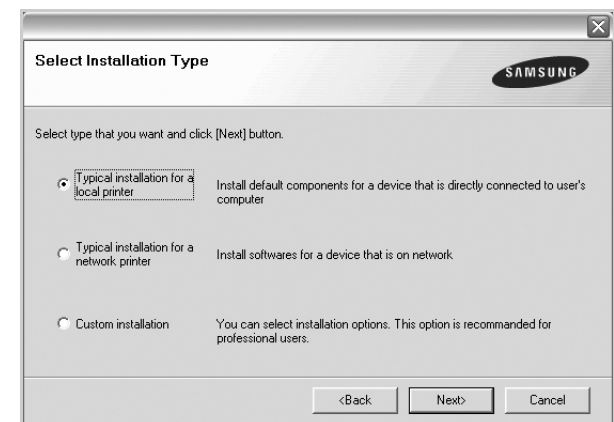

NOTE: If your printer is not already connected to the computer, the following window will appear.

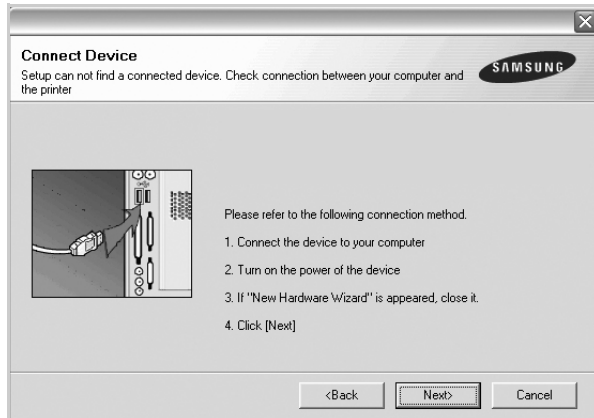

- After connecting the printer, click **Next**.
- If you don't want to connect the printer at this time, click **Next**, and **No** on the following screen. Then the installation will start and a test page will not be printed at the end of the installation.
- *The installation window that appears in this User's Guide may differ depending on the printer and interface in use.*

- 5 After the installation is finished, a window asking you to print a test page appears. If you choose to print a test page, select the checkbox and click **Next**. Otherwise, just click **Next** and skip to step 7.
- 6 If the test page prints out correctly, click **Yes**. If not, click **No** to reprint it.
- 7 To register yourself as a user of Samsung Printers in order to receive information from Samsung, select the checkbox and click **Finish**. You are now sent to the Samsung web site. Otherwise, just click **Finish**.

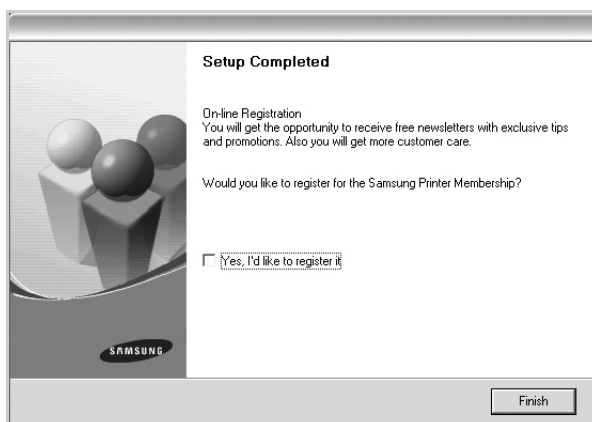

NOTE: After setup is complete, if your printer driver doesn't work properly, reinstall the printer driver. See "Reinstalling Printer Software" on page 10.

Custom Installation

You can choose individual components to install.

- 1 Make sure that the printer is connected to your computer and powered on.
- 2 Insert the supplied CD-ROM into your CD-ROM drive. The CD-ROM should automatically run, and an installation window appears. If the installation window does not appear, click **Start** and then **Run**. Type **X:\Setup.exe**, replacing "X" with the letter which represents your drive and click **OK**. If you use Windows Vista, click **Start** → **All programs** → **Accessories** → **Run**, and type **X:\Setup.exe**. If the **AutoPlay** window appears in Windows Vista, click **Run Setup.exe** in **Install or run program** field, and click **Continue** in the **User Account Control** window.

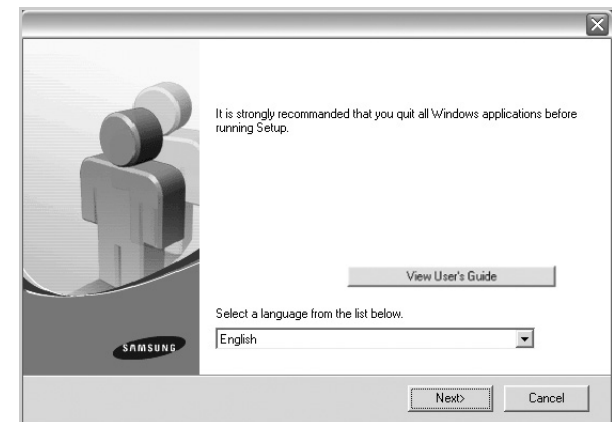

- 3 Click **Next**.
 - If necessary, select a language from the drop-down list.
 - **View User's Guide:** Allows you to view the User's Guide. If your computer doesn't have Adobe Acrobat, click on this option and it will automatically install Adobe Acrobat Reader for you.

4 Select **Custom installation**. Click **Next**.

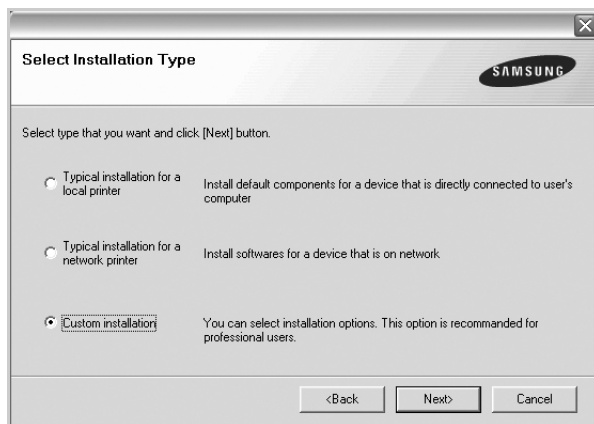

5 Select your printer and click **Next**.



NOTE: If your printer is not already connected to the computer, the following window will appear.

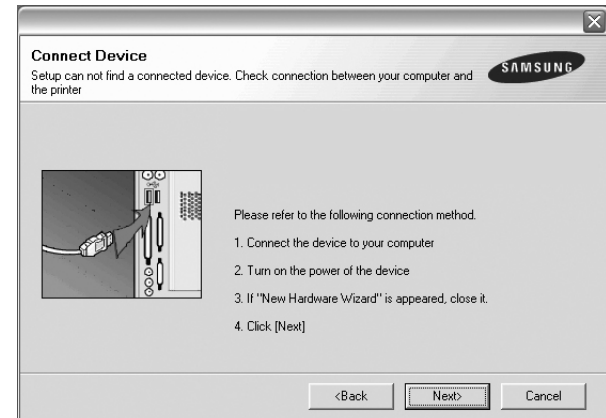

- After connecting the printer, click **Next**.
- If you don't want to connect the printer at this time, click **Next**, and **No** on the following screen. Then the installation will start and a test page will not be printed at the end of the installation.
- *The installation window that appears in this User's Guide may differ depending on the printer and interface in use.*

6 Select the components to be installed and click **Next**.

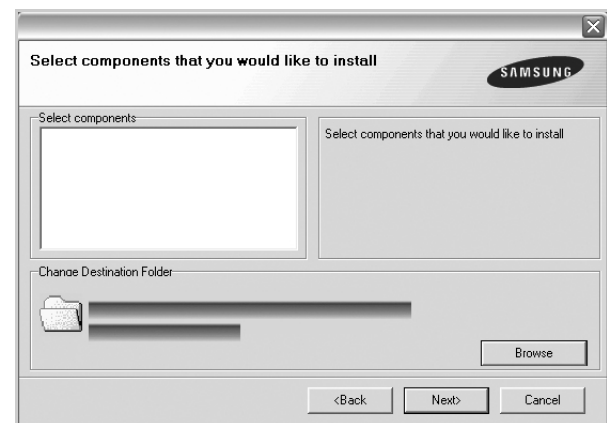

NOTE: You can change the desired installation folder by clicking [**Browse**].

- 7 After the installation is finished, a window asking you to print a test page appears. If you choose to print a test page, select the checkbox and click **Next**. Otherwise, just click **Next** and skip to step 9.
- 8 If the test page prints out correctly, click **Yes**. If not, click **No** to reprint it.

- 9 To register yourself as a user of Samsung Printers in order to receive information from Samsung, select the checkbox and click **Finish**. You are now sent to the Samsung web site.

Otherwise, just click **Finish**.

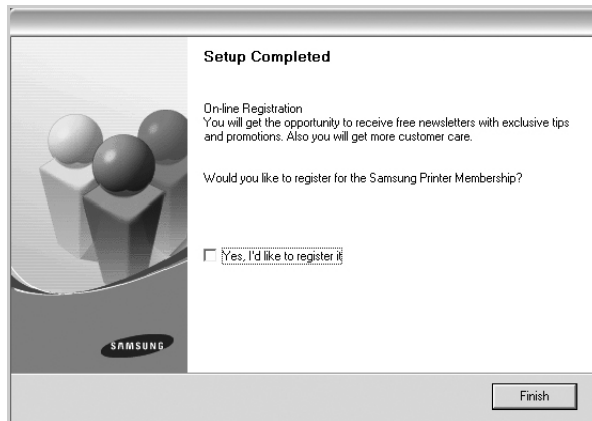

Installing Software for Network Printing

When you connect your printer to a network, you must first configure the TCP/IP settings for the printer. After you have assigned and verified the TCP/IP settings, you are ready to install the software on each computer on the network.

You can install the printer software using the typical or custom method.

Typical Installation

This is recommended for most users. All components necessary for printer operations will be installed.

- 1 Make sure that the printer is connected to your network and powered on. For details about connecting to the network, see the supplied printer's User's Guide.
- 2 Insert the supplied CD-ROM into your CD-ROM drive. The CD-ROM should automatically run, and an installation window appears.
If the installation window does not appear, click **Start** and then **Run**. Type **X:\Setup.exe**, replacing "X" with the letter which represents your drive and click **OK**.
If you use Windows Vista, click **Start** → **All programs** → **Accessories** → **Run**, and type **X:\Setup.exe**.

If the **AutoPlay** window appears in Windows Vista, click **Run Setup.exe** in **Install or run program** field, and click **Continue** in the **User Account Control** window.

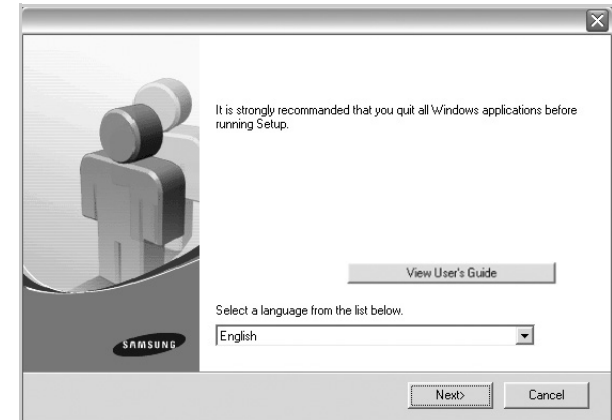

- 3 Click **Next**.
 - If necessary, select a language from the drop-down list.
 - **View User's Guide**: Allows you to view the User's Guide. If your computer doesn't have Adobe Acrobat, click on this option and it will automatically install Adobe Acrobat Reader for you.
- 4 Select **Typical installation for a network printer**. Click **Next**.

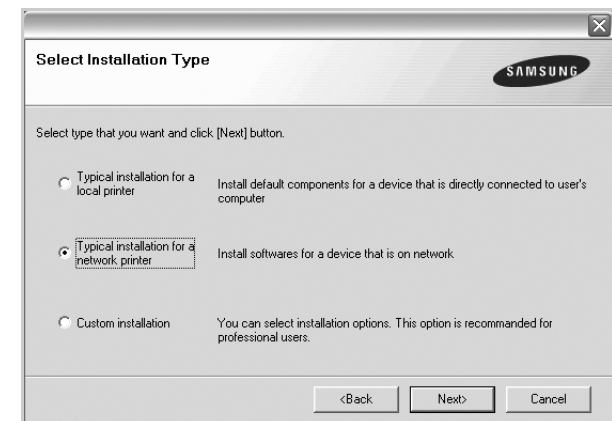

- 5 The list of printers available on the network appears. Select the printer you want to install from the list and then click **Next**.

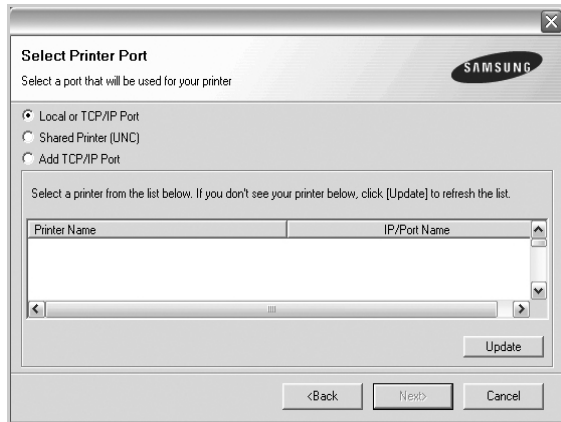

- If you do not see your printer on the list, click **Update** to refresh the list, or select **Add TCP/IP Port** to add your printer to the network. To add the printer to the network, enter the port name and the IP address for the printer.

To verify your printer's IP address or the MAC address, print a Network Configuration page.

- To find a shared network printer (UNC Path), select **Shared Printer [UNC]** and enter the shared name manually or find a shared printer by clicking the **Browse** button.

NOTE: If you cannot find your machine in network, please turn off the firewall and click **Update**.

- 6 After the installation is finished, a window appears asking you to print a test page and to register yourself as a user of Samsung Printers in order to receive information from Samsung. If you so desire, select the corresponding checkbox(es) and click **Finish**.

Otherwise, just click **Finish**.

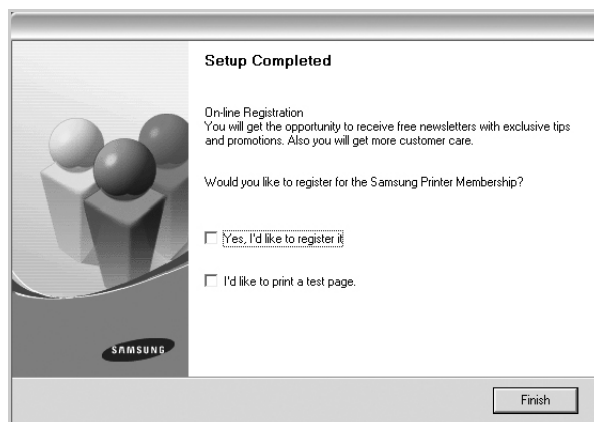

NOTE: After setup is complete, if your printer driver doesn't work properly, reinstall the printer driver. See "Reinstalling Printer Software" on page 10.

Custom Installation

You can choose individual components to install and set a specific IP address.

- 1 Make sure that the printer is connected to your network and powered on. For details about connecting to the network, see the supplied printer's User's Guide.
- 2 Insert the supplied CD-ROM into your CD-ROM drive. The CD-ROM should automatically run, and an installation window appears.

If the installation window does not appear, click **Start** and then **Run**. Type **X:\Setup.exe**, replacing "X" with the letter which represents your drive and click **OK**.

If you use Windows Vista, click **Start** → **All programs** → **Accessories** → **Run**, and type **X:\Setup.exe**.

If the **AutoPlay** window appears in Windows Vista, click **Run Setup.exe** in **Install or run program** field, and click **Continue** in the **User Account Control** window.

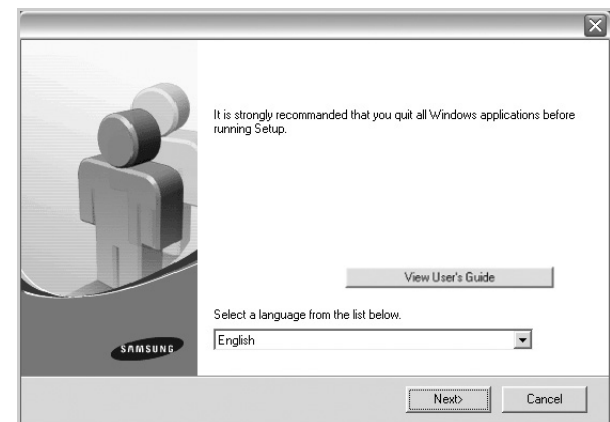

- 3 Click **Next**.
 - If necessary, select a language from the drop-down list.
 - **View User's Guide:** Allows you to view the User's Guide. If your computer doesn't have Adobe Acrobat, click on this option and it will automatically install Adobe Acrobat Reader for you.

4 Select **Custom installation**. Click **Next**.

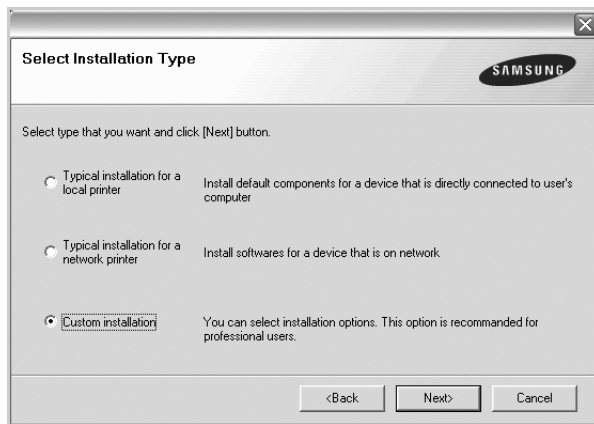

5 The list of printers available on the network appears. Select the printer you want to install from the list and then click **Next**.



- If you do not see your printer on the list, click **Update** to refresh the list, or select **Add TCP/IP Port** to add your printer to the network. To add the printer to the network, enter the port name and the IP address for the printer.

To verify your printer's IP address or the MAC address, print a Network Configuration page.

- To find a shared network printer (UNC Path), select **Shared Printer [UNC]** and enter the shared name manually or find a shared printer by clicking the **Browse** button.

NOTE: If you cannot find your machine in network, please turn off the firewall and click **Update**. For Windows operating system, click **Start** -> **Control Panel** and start windows firewall, and set this option unactivated. For other operating system, refer to its on-line guide.

TIP: If you want to set a specific IP address on a specific network printer, click the **Set IP Address** button. The Set IP Address window appears. Do as follows:

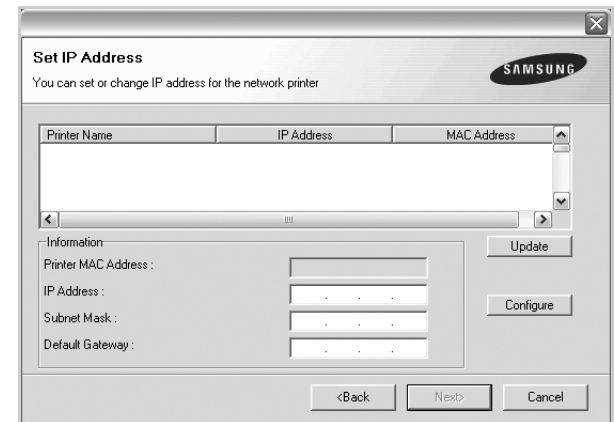

- a. Select a printer to be set with a specific IP address from the list.
- b. Configure an IP address, subnet mask, and gateway for the printer manually and click **Configure** to set the specific IP address for the network printer.
- c. Click **Next**.

6 Select the components to be installed. After selecting the components, the following window appears. You can also change the printer name, set the printer to be shared on the network, set the printer as the default printer, and change the port name of each printer. Click **Next**.

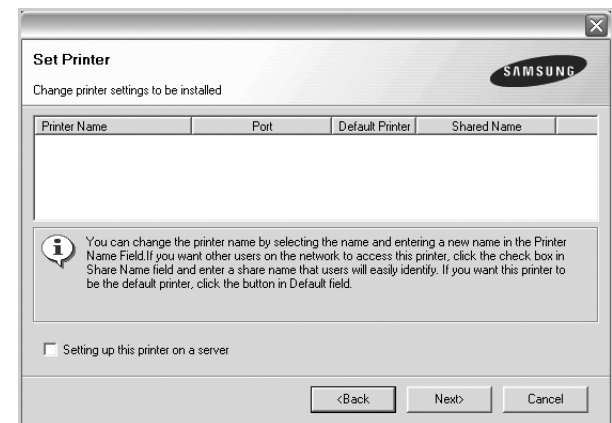

To install this software on a server, select the **Setting up this printer on a server** checkbox.

- 7 After the installation is finished, a window appears asking you to print a test page and to register yourself as a user of Samsung Printers in order to receive information from Samsung. If you so desire, select the corresponding checkbox(es) and click **Finish**.

Otherwise, just click **Finish**.

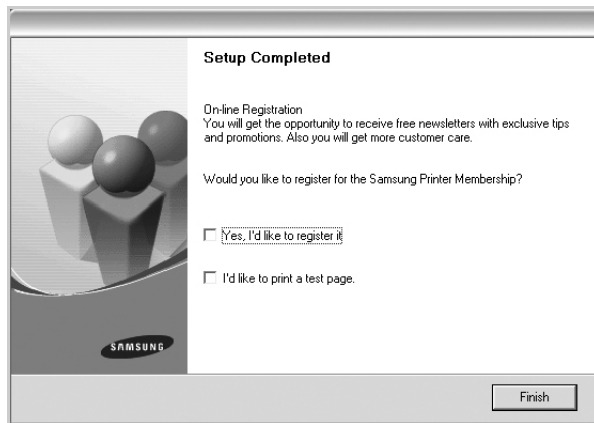

NOTE: After setup is complete, if your printer driver doesn't work properly, reinstall the printer driver. See "Reinstalling Printer Software" on page 10.

Reinstalling Printer Software

You can reinstall the software if installation fails.

- 1 Start Windows.
- 2 From the **Start** menu select **Programs** or **All Programs** → **your printer driver name** → **Maintenance**.
- 3 Select **Repair** and click **Next**.
- 4 The list of printers available on the network appears. Select the printer you want to install from the list and then click **Next**.

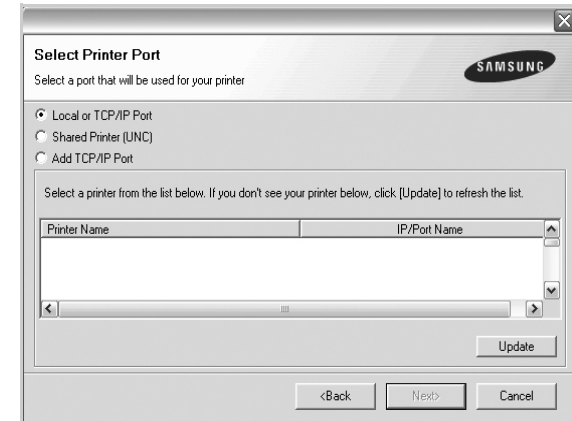

- If you do not see your printer on the list, click **Update** to refresh the list, or select **Add TCP/IP Port** to add your printer to the network. To add the printer to the network, enter the port name and the IP address for the printer.
- To find a shared network printer (UNC Path), select **Shared Printer [UNC]** and enter the shared name manually or find a shared printer by clicking the **Browse** button.

You will see a component list so that you can reinstall any item individually.

NOTE: If your printer is not already connected to the computer, the following window will appear.

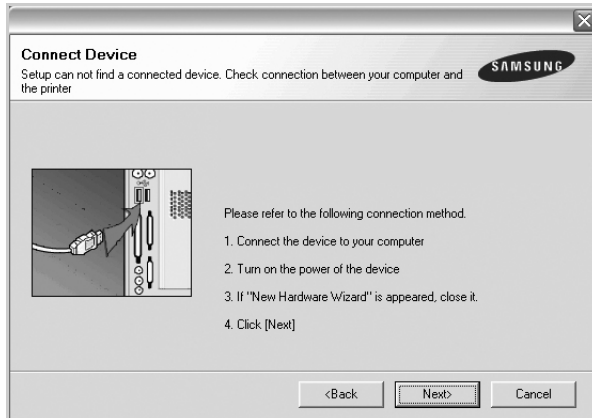

- After connecting the printer, click **Next**.
- If you don't want to connect the printer at this time, click **Next**, and **No** on the following screen. Then the installation will start and a test page will not be printed at the end of the installation.
- *The reinstallation window that appears in this User's Guide may differ depending on the printer and interface in use.*

- 5 Select the components you want to reinstall and click **Next**.

If you installed the printer software for local printing and you select **your printer driver name**, the window asking you to print a test page appears. Do as follows:

- a. To print a test page, select the check box and click **Next**.
 - b. If the test page prints out correctly, click **Yes**.
If it doesn't, click **No** to reprint it.
- 6 When the reinstallation is done, click **Finish**.

Removing Printer Software

- 1 Start Windows.
- 2 From the **Start** menu select **Programs** or **All Programs** → **your printer driver name** → **Maintenance**.
- 3 Select **Remove** and click **Next**.
You will see a component list so that you can remove any item individually.
- 4 Select the components you want to remove and then click **Next**.
- 5 When your computer asks you to confirm your selection, click **Yes**.
The selected driver and all of its components are removed from your computer.
- 6 After the software is removed, click **Finish**.

Installing mono printer driver

This printer features a monochrome-only printer. This mono driver limits output to the black toner, so you can use your printer as a monochrome printer. You must install the mono driver on your computer. Following steps guide you through the step by step installation process.

- 1 Make sure that the printer is connected to your computer and powered on. Or your computer and printer are connected to the network.
- 2 Insert the supplied CD-ROM into your CD-ROM drive. The CD-ROM should automatically run, and an installation window appears.
- 3 Click **Cancel**.

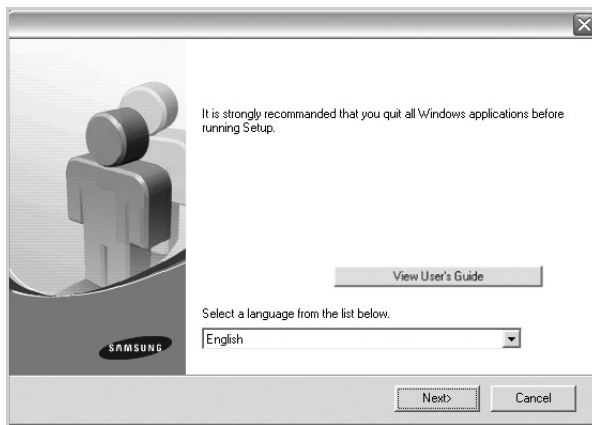

If the confirmation window appears, click **Finish**.

- 4 Click **Start** → **Printers and Faxes**.
- 5 Select **Add Printer**.
- 6 When **Add Printer Wizard** appears, click **Next**.
- 7 Select **Local printer attached to this computer**, and **Automatically detect and install my Plug and Play printer**, then click **Next**. Go to step 13.
If your computer does not find the printer, then follow the next step.
- 8 Select **Next** in the **Select a Printer Port** window.
- 9 In the **Select a Printer Port** window, select **Have Disk...**
- 10 Click **Browse** to find a mono driver for your printer.
ex) Windows XP 32 bit
Select CD-ROM drive → **Printer** → **PC_MONO** → **WINXP_2000_VISTA-32**
- 11 Select *****.inf** file and click **Open**.

- 12 Click **OK** in the **Install From Disk** window.

- 13 Select a mono driver in the **Printers** field, and click **Next**.

NOTE: If you have installed a mono driver before, then the **Use Existing Driver** window. Select as the window explains, and click **Next**. Also, depending on your computer configuration, the printer sharing window or the print the test page window may appear; make the appropriate selection.

- 14 Enter your printer name, and click **Next**.

- 15 Click **Finish** to start installing a mono printer driver.

NOTE: If your printer is connected to a network, go to printer's **Properties** and select the **Ports** tab, then click **Add Port** and **Standard TCP/IP Port**, and create a new port to connect to the printer. To create a new port, follow the procedure laid out in the wizard window.

2 Basic Printing

This chapter explains the printing options and common printing tasks in Windows.

This chapter includes:

- **Printing a Document**
- **Printing to a file (PRN)**
- **Printer Settings**
 - **Layout Tab**
 - **Paper Tab**
 - **Graphics Tab**
 - **Extras Tab**
 - **About Tab**
 - **Printer Tab**
 - **Using a Favorite Setting**
 - **Using Help**

Printing a Document

NOTES:

- Your printer driver **Properties** window that appears in this User's Guide may differ depending on the printer in use. However the composition of the printer properties window is similar.
- When you select an option in printer properties, you may see an exclamation (!) mark or X mark. An exclamation mark means you can select that certain option but it is not recommended, and X mark means you cannot select that option due to the machine's setting or environment.
- **Check the Operating System(s) that are compatible with your printer. Please refer to the OS Compatibility section of Printer Specifications in your Printer User's Guide.**
- If you need to know the exact name of your printer, you can check the supplied CD-ROM.

The following procedure describes the general steps required for printing from various Windows applications. The exact steps for printing a document may vary depending on the application program you are using. Refer to the User's Guide of your software application for the exact printing procedure.

- 1 Open the document you want to print.
- 2 Select **Print** from the **File** menu. The Print window is displayed. It may look slightly different depending on your application.

The basic print settings are selected within the Print window. These settings include the number of copies and print range.

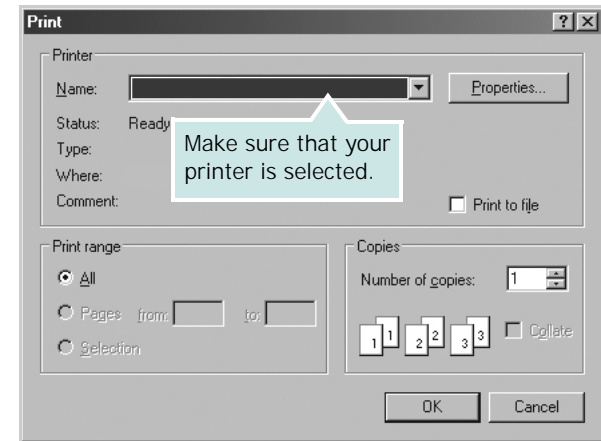

- 3 Select **your printer driver** from the **Name** drop-down list.

To take advantage of the printer features provided by your printer driver, click **Properties** or **Preferences** in the application's Print window. For details, see "Printer Settings" on page 14.

If you see **Setup**, **Printer**, or **Options** in your Print window, click it instead. Then click **Properties** on the next screen.

Click **OK** to close the printer properties window.

- 4 To start the print job, click **OK** or **Print** in the Print window.

Printing to a file (PRN)

You will sometimes need to save the print data as a file for your purpose.

To create a file:

- 1 Check the **Print to file** box at the **Print** window.

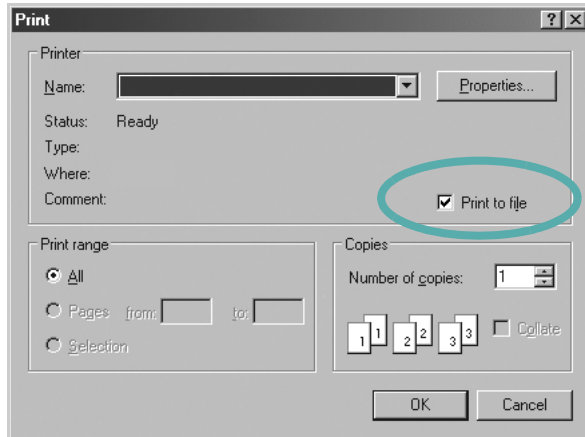

- 2 Select the folder and assign a name of the file and then click OK.

NOTES: To print the prn file, you must have the utility which sends prn file to USB port in DOS prompt.

Printer Settings

You can use the printer properties window, which allows you to access all of the printer options you need when using your printer. When the printer properties are displayed, you can review and change the settings needed for your print job.

Your printer properties window may differ, depending on your operating system. This Software User's Guide shows the Properties window for Windows XP.

Your printer driver **Properties** window that appears in this User's Guide may differ depending on the printer in use.

If you access printer properties through the Printers folder, you can view additional Windows-based tabs (refer to your Windows User's Guide) and the Printer tab (see "Printer Tab" on page 18).

NOTES:

- Most Windows applications will override settings you specify in the printer driver. Change all print settings available in the software application first, and change any remaining settings using the printer driver.
 - The settings you change remain in effect only while you are using the current program. **To make your changes permanent**, make them in the Printers folder.
 - The following procedure is for Windows XP. For other Windows OS, refer to the corresponding Windows User's Guide or online help.
 1. Click the Windows **Start** button.
 2. Select **Printers and Faxes**.
 3. Select **your printer driver icon**.
 4. Right-click on the printer driver icon and select **Printing Preferences**.
 5. Change the settings on each tab, click OK.
-

Layout Tab

The **Layout** tab provides options to adjust how the document appears on the printed page. The **Layout Options** includes **Multiple Pages per Side**, **Poster Printing** and **Booklet Printing**. See “Printing a Document” on page 13 for more information on accessing printer properties.

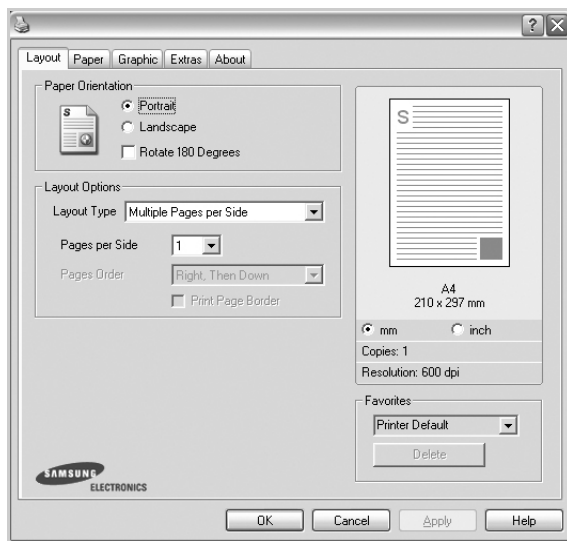

Paper Orientation

Paper Orientation allows you to select the direction in which information is printed on a page.

- **Portrait** prints across the width of the page, letter style.
- **Landscape** prints across the length of the page, spreadsheet style.
- **Rotate** allows you to rotate the page the selected degrees.

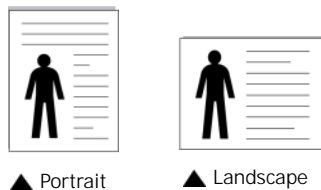

Layout Options

Layout Options allows you to select advanced printing options. You can choose **Multiple Pages per Side** and **Poster Printing**.

- For details, see “Printing Multiple Pages on One Sheet of Paper (N-Up Printing)” on page 19.
- For details, see “Printing Posters” on page 20
- For details, see “Printing Booklets” on page 20

Double-sided Printing

Double-sided Printing allows you to print on both sides of paper. *If this option does not appear, your printer does not have this feature.*

- For details, see “Printing on Both Sides of Paper” on page 21.

Paper Tab

Use the following options to set the basic paper handling specifications when you access the printer properties. See “Printing a Document” on page 13 for more information on accessing printer properties.

Click the **Paper** tab to access various paper properties.

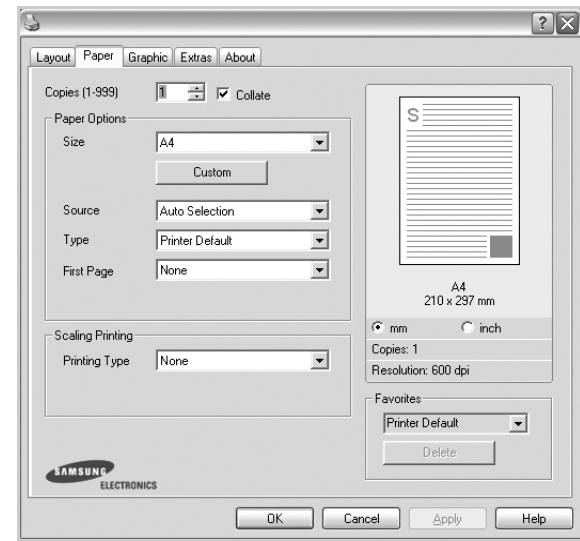

Copies

Copies allows you to choose the number of copies to be printed. You can select 1 to 999 copies.

Collate

This option automatically sorts the copies when you make more than two copies. For instance, if you make 2 copies of a 5-page document, the printer prints the document in order of pages 1 to 5 of the first copy, and pages 1 to 5 of the second copy. If you do not select this option, the printer prints the document in order of 1 to 1, 2 to 2, ..., 5 to 5 so you must sort the document after printing. *If this option does not appear, your printer does not have this feature.*

Paper Options

Size

Size allows you to set the size of paper you loaded in the tray. If the required size is not listed in the **Size** box, click **Custom**. When the **Custom Paper Setting** window appears, set the paper size and click **OK**. The setting appears in the list so that you can select it.

Source

Make sure that **Source** is set to the corresponding paper tray. Use **Manual Feeder** when printing on special materials like envelopes and transparencies. You have to load one sheet at a time into the Manual Tray or Multi-Purpose Tray. If the paper source is set to **Auto Selection**, the printer automatically picks up print material in the following tray order: Manual Tray or Multi-Purpose Tray, Tray n.

Type

Set **Type** to correspond to the paper loaded in the tray from which you want to print. This will let you get the best quality printout. If not, print quality may not be achieved as you want.

Cotton: 20 lb to 24 lb (75~90 g/m²) cotton paper such as Gilbert 25 % and Gilbert 100 %.

Plain Paper: Normal plain paper. Select this type if your printer is monochrome and printing on the 16 lb (60 g/m²) cotton paper.

Recycled Paper: 20 lb to 24 lb (75~90 g/m²) recycled paper.

Color: 20 lb to 24 lb (75~90 g/m²) color-backgrounded paper.

Thick: 24 lb to 28 lb (90~105 g/m²) thick paper.

Thin: 16 lb to 19 lb (60~70 g/m²) thin paper.

Bond: When you use the bond paper, select this option.

Archive: When you need to keep print-out for a long period time such as archives, select this option.

First Page

This property allows you to print the first page using a different paper type from the rest of the document. You can select the paper source for the first page.

For example, load thick stock for the first page into the Multi-purpose Tray, and plain paper into Tray n. Then, select **Tray n** in the **Source** option and **Multi-Purpose Tray** in the **First Page** option. *If this option does not appear, your printer does not have this feature.*

Scaling Printing

Scaling Printing allows you to automatically or manually scale your print job on a page. You can choose from **None**, **Reduce/Enlarge**, and **Fit to Page**.

- For details, see “Printing a Reduced or Enlarged Document” on page 21.
- For details, see “Fitting Your Document to a Selected Paper Size” on page 21.

Graphics Tab

Use the following Graphic options to adjust the print quality for your specific printing needs. See “Printing a Document” on page 13 for more information on accessing printer properties.

Click the **Graphic** tab to display the properties shown below.

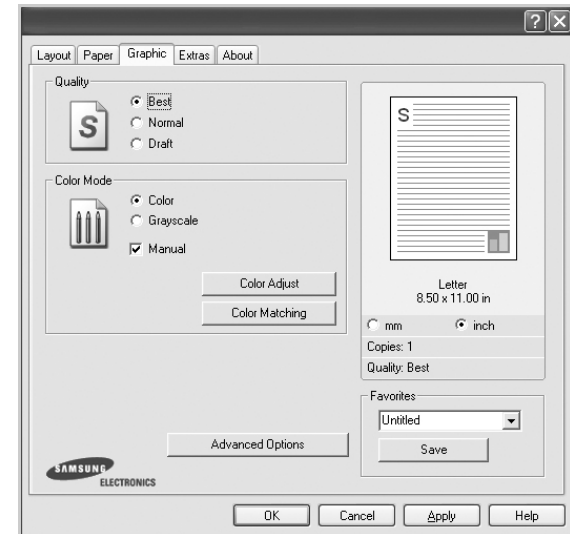

Quality

The Quality options you can select may vary depending on your printer model. The higher the setting, the sharper the clarity of printed characters and graphics. The higher setting also may increase the time it takes to print a document.

Color Mode

You can choose color options. Setting to **Color** typically produces the best possible print quality for color documents. If you want to print a color document in grayscale, select **Grayscale**. If you want to adjust the color options manually, select **Manual** and click the **Color Adjust** or **Color Matching** button.

- **Color Adjust** : You can adjust the appearance of images by changing the settings in the **Levels** option.
- **Color Matching** : You can adjust the appearance of images by changing the settings in the **Settings** option.
- **Copies Setting** : When you make several copies, and if you want to make some of copies are printed in color and others are in grayscale, use this option and select the number of copies in grayscale.

Advanced Options

You can set advanced settings by clicking the **Advanced Options** button.

- **Raster Compression:** This option determines the compression level of images for transferring data from a computer to a printer. If you set this option to Maximum, the printing speed will be high, but the printing quality will be low. *This feature is available only when you use the PCL6 printer driver.*
- **TrueType Options:** This option determines what the driver tells the printer about how to image the text in your document. Select the appropriate setting according to the status of your document.
 - **Download as Outline:** When this option is selected, the driver will download any TrueType fonts that are used in your document not already stored (resident) on your printer. If, after printing a document, you find that the fonts did not print correctly, choose Download as bit image and resubmit your print job. The Download as bit image setting is often useful when printing Adobe. *This feature is available only when you use the PCL6 printer driver.*
 - **Download as Bitmap:** When this option is selected, the driver will download the font data as bitmap images. Documents with complicated fonts, such as Korean or Chinese, or various other fonts, will print faster in this setting. *This feature is available only when you use the PCL6 printer driver.*
 - **Print as Graphics:** When this option is selected, the driver will download any fonts as graphics. When printing documents with high graphic content and relatively few TrueType fonts, printing performance (speed) may be enhanced in this setting. *This feature is available only when you use the PCL6 printer driver.*
- **Print All Text To Black:** When the **Print All Text To Black** option is checked, all text in your document prints solid black, regardless of the color it appears on the screen.
- **Print All Text To Darken:** When the **Print All Text To Darken** option is checked, all text in your document is allowed to print darker than on a normal document. *This feature is available only when you use the SPL printer driver.*
- **Grayscale Enhancement:** Press the **Smart Color** tab. It allows users to preserve the details of nature photos, and improve contrast and readability among gray scaled colors, when printing color documents in grayscale.
- **Fine Edge:** Press the **Smart Color** tab. It allows users to emphasize edges of texts and fine lines for improving readability and align each color channel registration in color printing mode. *This feature is available only when you use the SPL printer driver.*

Extras Tab

You can select output options for your document. See “Printing a Document” on page 13 for more information about accessing the printer properties.

Click the **Extras** tab to access the following feature:

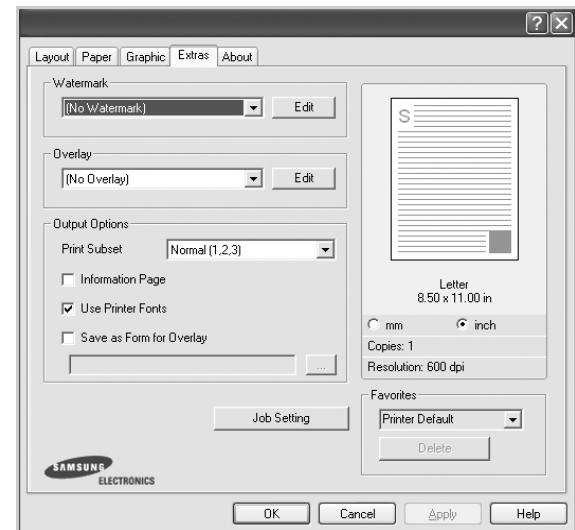

Watermark

You can create a background text image to be printed on each page of your document. For details, see “Using Watermarks” on page 22.

Overlay

Overlays are often used to take the place of preprinted forms and letterhead paper. For details, see “Using Overlays” on page 23.

Output Options

- **Print Subset:** You can set the sequence in which the pages print. Select the print order from the drop-down list.
 - **Normal (1,2,3):** Your printer prints all pages from the first page to the last page.
 - **Reverse All Pages (3,2,1):** Your printer prints all pages from the last page to the first page.
 - **Print Odd Pages:** Your printer prints only the odd numbered pages of the document.
 - **Print Even Pages:** Your printer prints only the even numbered pages of the document.
- **Use Printer Fonts:** When Use Printer Fonts is checked, the printer uses the fonts that are stored in its memory (resident fonts) to print your document, rather than downloading the fonts used in your document. Because downloading fonts takes time, selecting this option can speed up your printing time. When using Printer fonts, the printer will try to match the fonts used in your document to those stored in its memory. If, however, you use fonts in your document that are very different from those resident in the printer, your printed output will appear very different from what it looks like on the screen. *This feature is available only when you use the PCL6 printer driver.*

About Tab

Use the **About** tab to display the copyright notice and the version number of the driver. If you have an Internet browser, you can connect to the Internet by clicking on the web site icon. See "Printing a Document" on page 13 for more information about accessing printer properties.

Printer Tab

If you access printer properties through the **Printers** folder, you can view the **Printer** tab. You can set the printer configuration.

The following procedure is for Windows XP. For other Windows OS, refer to the corresponding Windows User's Guide or online help.

- 1 Click the Windows **Start** menu.
- 2 Select **Printers and Faxes**.
- 3 Select **your printer driver** icon.
- 4 Right-click on the printer driver icon and select **Properties**.
- 5 Click the **Printer** tab and set the options.

Using a Favorite Setting

The **Favorites** option, which is visible on each properties tab, allows you to save the current properties settings for future use.

To save a **Favorites** item:

- 1 Change the settings as needed on each tab.
- 2 Enter a name for the item in the **Favorites** input box.

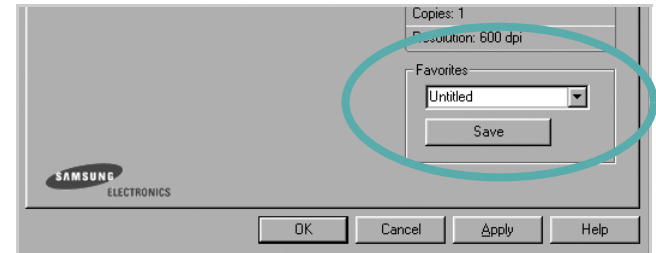

- 3 Click **Save**.

When you save **Favorites**, all current driver settings are saved.

To use a saved setting, select the item from the **Favorites** drop down list. The printer is now set to print according to the Favorites setting you selected.

To delete a Favorites item, select it from the list and click **Delete**.

You can also restore the printer driver's default settings by selecting **Printer Default** from the list.

Using Help

Your printer has a help screen that can be activated by clicking the **Help** button in the printer properties window. These help screens give detailed information about the printer features provided by the printer driver.

You can also click  from the upper right corner of the window, and then click on any setting.

3 Advanced Printing

This chapter explains printing options and advanced printing tasks.

NOTE:

- Your printer driver **Properties** window that appears in this User's Guide may differ depending on the printer in use. However the composition of the printer properties window is similar.
 - If you need to know the exact name of your printer, you can check the supplied CD-ROM.
-

This chapter includes:

- **Printing Multiple Pages on One Sheet of Paper (N-Up Printing)**
- **Printing Posters**
- **Printing Booklets**
- **Printing on Both Sides of Paper**
- **Printing a Reduced or Enlarged Document**
- **Fitting Your Document to a Selected Paper Size**
- **Using Watermarks**
- **Using Overlays**

Printing Multiple Pages on One Sheet of Paper (N-Up Printing)



You can select the number of pages to print on a single sheet of paper. To print more than one page per sheet, the pages will be reduced in size and arranged in the order you specify. You can print up to 16 pages on one sheet.

- 1** To change the print settings from your software application, access printer properties. See “Printing a Document” on page 13.
- 2** From the **Layout** tab, choose **Multiple Pages per Side** in the **Layout Type** drop-down list.
- 3** Select the number of pages you want to print per sheet (1, 2, 4, 6, 9, or 16) in the **Pages per Side** drop-down list.
- 4** Select the page order from the **Page Order** drop-down list, if necessary.
Check **Print Page Border** to print a border around each page on the sheet.
- 5** Click the **Paper** tab, select the paper source, size, and type.
- 6** Click **OK** and print the document.

Printing Posters

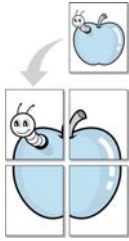

This feature allows you to print a single-page document onto 4, 9, or 16 sheets of paper, for the purpose of pasting the sheets together to form one poster-size document.

- 1 To change the print settings from your software application, access printer properties. See “Printing a Document” on page 13.
- 2 Click the **Layout** tab, select **Poster Printing** in the **Layout Type** drop-down list.
- 3 Configure the poster option:

You can select the page layout from **Poster<2x2>**, **Poster<3x3>** or **Poster<4x4>**. If you select **Poster<2x2>**, the output will be automatically stretched to cover 4 physical pages.



▲ 2x2

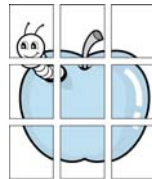

▲ 3x3

Specify an overlap in millimeters or inches to make it easier to pasting the sheets together.

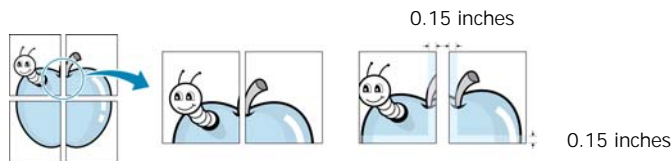

- 4 Click the **Paper** tab, select the paper source, size, and type.
- 5 Click **OK** and print the document. You can complete the poster by pasting the sheets together.

Printing Booklets



This printer feature allows you to print your document on both sides of the paper and arranges the pages so that the paper can be folded in half after printing to produce a booklet.

- 1 To change the print settings from your software application, access the printer properties. See “Printing a Document” on page 13.
- 2 From the **Layout** tab, choose **Booklet Printing** from the **Layout Type** drop-down list.

NOTE: The **Booklet Printing** option is not available for all paper sizes. In order to find out the available paper size for this feature, select the paper size in the **Size** option on the **Paper** tab, then check if the **Booklet Printing** in a **Layout Type** drop-down list on the **Layout** tab is activated.

- 3 Click the **Paper** tab, and select the paper source, size, and type.
- 4 Click **OK** and print the document.
- 5 After printing, fold and staple the pages.

Printing on Both Sides of Paper

You can print on both sides of a sheet of paper. Before printing, decide how you want your document oriented.

The options are:

- **Printer Setting**, if you select this option, this feature is determined by the setting you've made on the control panel of the printer. *If this option does not appear, your printer does not have this feature.*
- **None**
- **Long Edge**, which is the conventional layout used in book binding.
- **Short Edge**, which is the type often used with calendars.

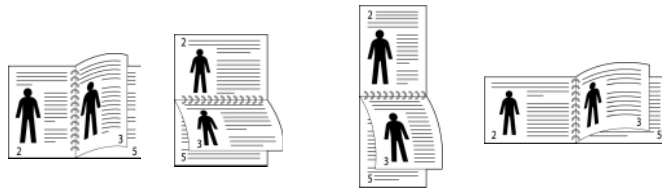

▲ Long Edge

▲ Short Edge

- **Reverse Duplex Printing**, allows you to select general print order compare to duplex print order. *If this option does not appear, your printer does not have this feature.*

NOTE: Do not print on both sides of labels, transparencies, envelopes, or thick paper. Paper jamming and damage to the printer may result.

- 1 To change the print settings from your software application, access printer properties. "Printing a Document" on page 13.
- 2 From the **Layout** tab, select the paper orientation.
- 3 From the **Double-sided Printing** section, select the binding option you want.
- 4 Click the **Paper** tab and select the paper source, size, and type.
- 5 Click **OK** and print the document.

NOTE: If your printer does not have a duplex unit, you should complete the printing job manually. The printer prints every other page of the document first. After printing the first side of your job, the Printing Tip window appears. Follow the on-screen instructions to complete the printing job.

Printing a Reduced or Enlarged Document

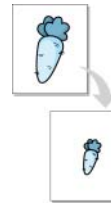

You can change the size of a page's content to appear larger or smaller on the printed page.

- 1 To change the print settings from your software application, access printer properties. See "Printing a Document" on page 13.
- 2 From the **Paper** tab, select **Reduce/Enlarge** in the **Printing Type** drop-down list.
- 3 Enter the scaling rate in the **Percentage** input box. You can also click the ▼ or ▲ button.
- 4 Select the paper source, size, and type in **Paper Options**.
- 5 Click **OK** and print the document.

Fitting Your Document to a Selected Paper Size

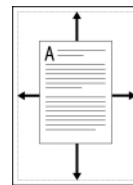

This printer feature allows you to scale your print job to any selected paper size regardless of the digital document size. This can be useful when you want to check fine details on a small document.

- 1 To change the print settings from your software application, access printer properties. See "Printing a Document" on page 13.
- 2 From the **Paper** tab, select **Fit to Page** in the **Printing Type** drop-down list.
- 3 Select the correct size from the **Output size** drop-down list.
- 4 Select the paper source, size, and type in **Paper Options**.
- 5 Click **OK** and print the document.

Using Watermarks

The Watermark option allows you to print text over an existing document. For example, you may want to have large gray letters reading "DRAFT" or "CONFIDENTIAL" printed diagonally across the first page or all pages of a document.

There are several predefined watermarks that come with the printer, and they can be modified, or you can add new ones to the list.

Using an Existing Watermark

- 1 To change the print settings from your software application, access printer properties. See "Printing a Document" on page 13.
- 2 Click the **Extras** tab, and select the desired watermark from the **Watermark** drop-down list. You will see the selected watermark in the preview image.
- 3 Click **OK** and start printing.

NOTE: The preview image shows how the page will look when it is printed.

Creating a Watermark

- 1 To change the print settings from your software application, access printer properties. See "Printing a Document" on page 13.
- 2 Click the **Extras** tab, and click the **Edit** button in the **Watermark** section. The **Edit Watermark** window appears.
- 3 Enter a text message in the **Watermark Message** box. You can enter up to 40 characters. The message displays in the preview window.
When the **First Page Only** box is checked, the watermark prints on the first page only.
- 4 Select watermark options.
You can select the font name, style, size, or grayscale level from the **Font Attributes** section and set the angle of the watermark from the **Message Angle** section.
- 5 Click **Add** to add a new watermark to the list.
- 6 When you have finished editing, click **OK** and start printing.

To stop printing the watermark, select **(No Watermark)** from the **Watermark** drop-down list.

Editing a Watermark

- 1 To change the print settings from your software application, access printer properties. See "Printing a Document" on page 13.
- 2 Click the **Extras** tab and click the **Edit** button in the **Watermark** section. The **Edit Watermark** window appears.
- 3 Select the watermark you want to edit from the **Current Watermarks** list and change the watermark message and options.
- 4 Click **Update** to save the changes.
- 5 Click **OK** until you exit the Print window.

Deleting a Watermark

- 1 To change the print settings from your software application, access printer properties. See "Printing a Document" on page 13.
- 2 From the **Extras** tab, click the **Edit** button in the Watermark section. The **Edit Watermark** window appears.
- 3 Select the watermark you want to delete from the **Current Watermarks** list and click **Delete**.
- 4 Click **OK** until you exit the Print window.

Using Overlays

What is an Overlay?



An overlay is text and/or images stored in the computer hard disk drive (HDD) as a special file format that can be printed on any document. Overlays are often used to take the place of preprinted forms and letterhead paper. Rather than using preprinted letterhead, you can create an overlay containing the exact same information that is currently on your letterhead. To print a letter with your company's letterhead, you do not need to load preprinted letterhead paper in the printer. You need only tell the printer to print the letterhead overlay on your document.

Creating a New Page Overlay



To use a page overlay, you must create a new page overlay containing your logo or image.

- 1 Create or open a document containing text or an image for use in a new page overlay. Position the items exactly as you wish them to appear when printed as an overlay.
- 2 To save the document as an overlay, access printer properties. See "Printing a Document" on page 13.
- 3 Click the **Extras** tab, and click **Edit** button in the **Overlay** section.
- 4 In the Edit Overlay window, click **Create Overlay**.
- 5 In the Create Overlay window, type a name of up to eight characters in the **File name** box. Select the destination path, if necessary. (The default is C:\Formover).
- 6 Click **Save**. The name appears on the **Overlay List** box.
- 7 Click **OK** or **Yes** to finish creating.
The file is not printed. Instead it is stored on your computer hard disk drive.

NOTE: The overlay document size must be the same as the documents you print with the overlay. Do not create an overlay with a watermark.

Using a Page Overlay

After an overlay has been created, it is ready to be printed with your document. To print an overlay with a document:

- 1 Create or open the document you want to print.
- 2 To change the print settings from your software application, access printer properties. See "Printing a Document" on page 13.
- 3 Click the **Extras** tab.
- 4 Select the desired overlay from the **Overlay** drop-down list box.
- 5 If the overlay file you want does not appear in the **Overlay** list, click **Edit** button and **Load Overlay**, and select the overlay file.

If you have stored the overlay file you want to use in an external source, you can also load the file when you access the **Load Overlay** window.

After you select the file, click **Open**. The file appears in the **Overlay List** box and is available for printing. Select the overlay from the **Overlay List** box.

- 6 If necessary, click **Confirm Page Overlay When Printing**. If this box is checked, a message window appears each time you submit a document for printing, asking you to confirm your wish to print an overlay on your document.
If this box is not checked and an overlay has been selected, the overlay automatically prints with your document.
- 7 Click **OK** or **Yes** until printing begins.
The selected overlay downloads with your print job and prints on your document.

NOTE: The resolution of the overlay document must be the same as that of the document you will print with the overlay.

Deleting a Page Overlay

You can delete page overlays that you no longer use.

- 1 In the printer properties window, click the **Extras** tab.
- 2 Click the **Edit** button in the **Overlay** section.
- 3 Select the overlay you want to delete from the **Overlay List** box.
- 4 Click **Delete Overlay**.
- 5 When a confirming message window appears, click **Yes**.
- 6 Click **OK** until you exit the Print window.

4 Using Windows PostScript Driver

If you want to use the PostScript driver provided with your system CD-ROM to print a document.

PPDs, in combination with the PostScript driver, access printer features and allow the computer to communicate with the printer. An installation program for the PPDs is provided on the supplied software CD-ROM.

Printer Settings

You can use the printer properties window, which allows you to access all of the printer options you need when using your printer. When the printer properties are displayed, you can review and change the settings needed for your print job.

Your printer properties window may differ, depending on your operating system. This Software User's Guide shows the Properties window for Windows XP.

Your printer driver **Properties** window that appears in this User's Guide may differ depending on the printer in use.

NOTES:

- Most Windows applications will override settings you specify in the printer driver. Change all print settings available in the software application first, and change any remaining settings using the printer driver.
 - The settings you change remain in effect only while you are using the current program. **To make your changes permanent**, make them in the Printers folder.
 - The following procedure is for Windows XP. For other Windows OS, refer to the corresponding Windows User's Guide or online help.
 1. Click the Windows **Start** button.
 2. Select **Printers and Faxes**.
 3. Select **your printer driver icon**.
 4. Right-click on the printer driver icon and select **Printing Preferences**.
 5. Change the settings on each tab, click OK.
-

Advanced

You can use advanced settings by clicking the **Advanced** button.

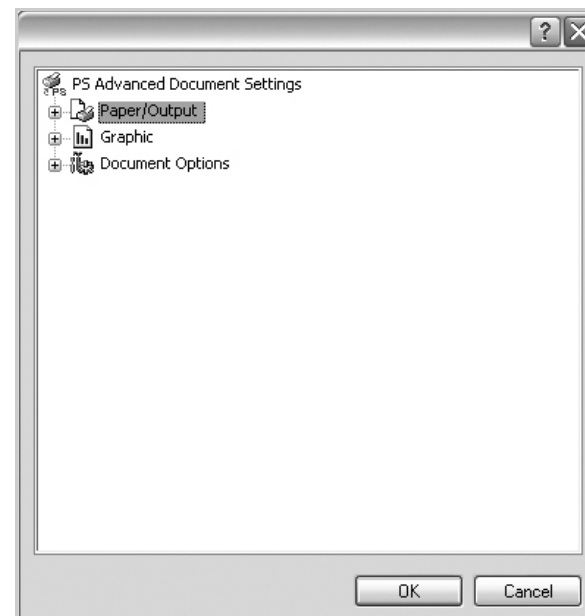

- **Paper/Output** this option allows you to select the size of the paper loaded in the tray.
- **Graphic** this option allows you to adjust the print quality for your specific printing needs.
- **Document Options** this options allow you to set the PostScript options or printer features.

Using Help

You can click  from the upper right corner of the window, and then click on any setting.

5 Sharing the Printer Locally

You can connect the printer directly to a selected computer, which is called “host computer,” on the network.

The following procedure is for Windows XP. For other Windows OS, refer to the corresponding Windows User's Guide or online help.

NOTES:

- Check the Operating System(s) that are compatible with your printer. Please refer to the OS Compatibility section of Printer Specifications in your Printer User's Guide.
 - If you need to know the exact name of your printer, you can check the supplied CD-ROM.
-

Setting Up a Host Computer

- 1 Start Windows.
- 2 From the **Start** menu select **Printers and Faxes**.
- 3 Double-click **your printer driver icon**.
- 4 From the **Printer** menu, select **Sharing**.
- 5 Check the **Share this printer** box.
- 6 Fill in the **Shared Name** field, and then click **OK**.

Setting Up a Client Computer

- 1 Right-click the Windows **Start** button and select **Explorer**.
- 2 Select **My Network Places** and then right-click **Search for Computers**.
- 3 Fill in the IP address of host computer in **Computer name** field, and click **Search**. (In case host computer requires **User name** and **Password**, fill in User ID and password of host computer account.)
- 4 Double-click **Printers and Faxes**.
- 5 Right-click printer driver icon, select **Connect**.
- 6 Click **Yes**, if the installation confirm message appears.

6 Using Smart Panel

Smart Panel is a program that monitors and informs you of the status of the printer, and allows you to customize the printer's settings. Smart Panel is installed automatically when you install the printer software.

NOTES:

- To use this program, you need:
 - To check for Operating System(s) that are compatible with your printer, refer to Printer Specifications in your Printer User's Guide.
 - Mac OS X 10.3 or higher
 - Linux. To check for Linux systems that are compatible with your printer, refer to Printer Specifications in your Printer User's Guide.
 - Internet Explorer version 5.0 or higher for flash animation in HTML Help.
- If you need to know the exact name of your printer, you can check the supplied CD-ROM.

Understanding Smart Panel

If an error occurs while printing, Smart Panel appears automatically, showing the error.

You can also launch Smart Panel manually. Double-click the Smart Panel icon on the Windows task bar (in Windows), or Notification Area (in Linux). You can also click it on the status bar (in Mac OS X).

Double-click this icon in Windows.



Click this icon in Mac OS X.



Click this icon in Linux.



If you are a Windows user, from the **Start** menu, select **Programs** or **All Programs** → **your printer driver name** → **Smart Panel**.

NOTES:

- If you have already installed more than one Samsung printer, first select the printer model you want in order to use the corresponding Smart Panel. Right-click (in Windows or Linux) or click (in Mac OS X) the Smart Panel icon and select **your printer name**.
- The Smart Panel window and its contents shown in this Software User's Guide may differ depending on the printer or Operating System in use.

The Smart Panel program displays the current status of the printer, the level of toner remaining in the toner cartridge(s) and various other information. You can also change settings.

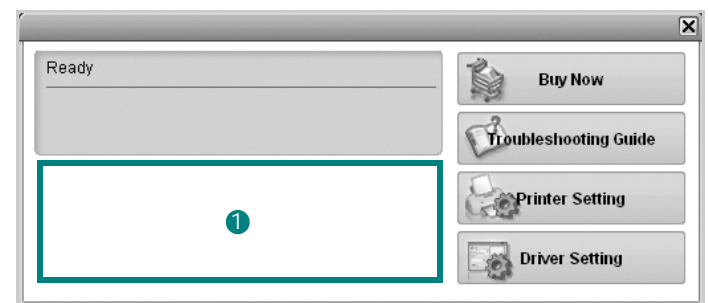

1 Toner Level

You can view the level of toner remaining in the toner cartridge(s). The printer and the number of toner cartridge(s) shown in the above window may differ depending on the printer in use. Any printers do not have this feature.

Buy Now

You can order replacement toner cartridge(s) online.

Troubleshooting Guide

You can view Help to solve problems.

Printer Setting

You can configure various printer settings in the Printer Settings Utility window. Any printers do not have this feature.

NOTE: If your printer is connected to a network and you are a Windows user, the **SyncThru Web Service** window appears instead of the Printer Settings Utility window. Linux does not support network environments.

Driver Setting (Only for Windows)

You can use the printer properties window, which allows you to access all of the printer options you need for using your printer. For details, See "Printer Settings" on page 14.

Opening the Troubleshooting Guide

Using the troubleshooting guide, you can view solutions for error status problems.

Right-click (in Windows or Linux) or click (in Mac OS X) the Smart Panel icon and select **Troubleshooting Guide**.

Using Printer Settings Utility

Using the Printer Settings Utility, you can configure and check print settings.

- 1 Right-click (in Windows or Linux) or click (in Mac OS X) the Smart Panel icon and select **Printer Setting**.
- 2 Change the settings.
- 3 To send the changes to the printer, click the **Apply** button.

NOTES: If your printer is connected to a network, the **SyncThru Web Service** window appears instead of the Printer Settings Utility window.

Using Onscreen Help File

For more information about **Printer Settings Utility**, click  .

Changing the Smart Panel Program Settings

Right-click (in Windows or Linux) or click (in Mac OS X) the Smart Panel icon and select **Options**. Select the settings you want from the **Options** window.

7 Using Your Printer in Linux

You can use your machine in a Linux environment.

This chapter includes:

- **Getting Started**
- **Installing the Unified Linux Driver**
- **Using the Unified Driver Configurator**
- **Configuring Printer Properties**
- **Printing a Document**

Getting Started

The supplied CD-ROM provides you with Samsung's Unified Linux Driver package for using your machine with a Linux computer.

After the driver is installed on your Linux system, the driver package allows you to monitor a number of machine devices via fast ECP parallel ports and USB simultaneously.

The Unified Linux Driver package is supplied with a smart and flexible installation program. You don't need to search for additional components that might be necessary for the Unified Linux Driver software: all required packages will be carried onto your system and installed automatically; this is possible on a wide set of the most popular Linux clones.

Installing the Unified Linux Driver

Installing the Unified Linux Driver

- 1 Make sure that you connect your machine to your computer. Turn both the computer and the machine on.
- 2 When the Administrator Login window appears, type in *root* in the Login field and enter the system password.

NOTE: You must log in as a super user (*root*) to install the printer software. If you are not a super user, ask your system administrator.

- 3 Insert the printer software CD-ROM. The CD-ROM will automatically run.

If the CD-ROM does not automatically run, click the  icon at the bottom of the desktop. When the Terminal screen appears, type in:

If the CD-ROM is secondary master and the location to mount is `/mnt/cdrom`,

```
[root@localhost root]#mount -t iso9660 /dev/hdc /mnt/cdrom
```

```
[root@localhost root]#cd /mnt/cdrom/Linux
```

```
[root@localhost root]#./install.sh
```

If you still failed to run the CD-ROM, type the followings in sequence:

```
[root@localhost root]#umount/dev/hdc
```

```
[root@localhost root]#mount -t iso9660 /dev/hdc /mnt/cdrom
```

NOTE: The installation program runs automatically if you have an autorun software package installed and configured.

- 4 When the welcome screen appears, click **Next**.

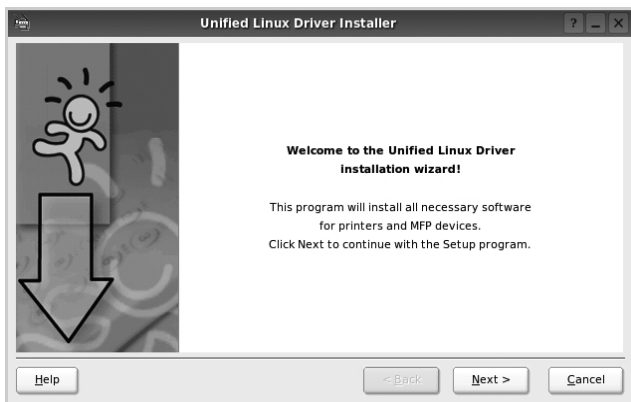

- 5 When the installation is complete, click **Finish**.

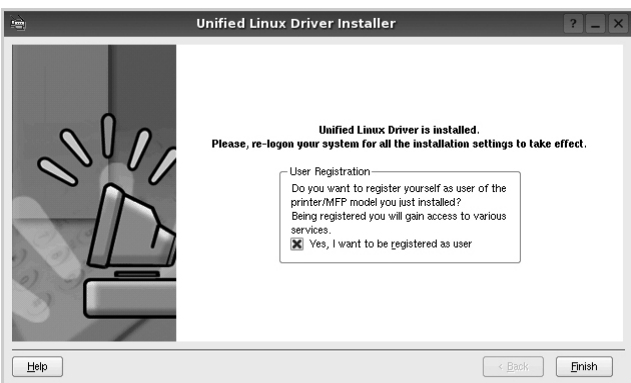

The installation program has added the Unified Driver Configurator desktop icon and Samsung Unified Driver group to the system menu for your convenience. If you have any difficulties, consult the onscreen help that is available through your system menu or can otherwise be called from the driver package windows applications, such as **Unified Driver Configurator**.

NOTES: Installing the driver in the text mode:

- If you do not use the graphical interface or have failed the driver installation, you have to use the driver in the text mode.
- Follow the step 1 to 3, then type `[root@localhost Linux]# ./install.sh`, then follow the instruction on the terminal screen. Then the installation completes.
- When you want to uninstall the driver, follow the installation instruction above, but type `[root@localhost Linux]# ./uninstall.sh` on the terminal screen.

Uninstalling the Unified Linux Driver

- 1 When the Administrator Login window appears, type in `root` in the Login field and enter the system password.

NOTE: You must log in as a super user (`root`) to install the printer software. If you are not a super user, ask your system administrator.

- 2 Insert the printer software CD-ROM. The CD-ROM will automatically run.

If the CD-ROM does not automatically run, click the  icon at the bottom of the desktop. When the Terminal screen appears, type in:

If the CD-ROM is secondary master and the location to mount is `/mnt/cdrom`,

```
[root@localhost root]#mount -t iso9660 /dev/hdc /mnt/cdrom
```

```
[root@localhost root]#cd /mnt/cdrom/Linux
```

```
[root@localhost root]#./uninstall.sh
```

NOTE: The installation program runs automatically if you have an autorun software package installed and configured.

- 3 Click **Uninstall**.
- 4 Click **Next**.

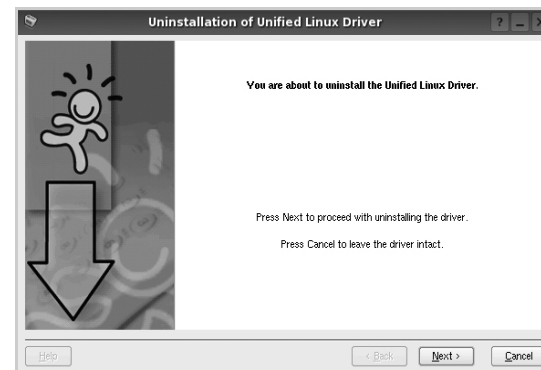

- 5 Click **Finish**.

Using the Unified Driver Configurator

Unified Linux Driver Configurator is a tool primarily intended for configuring Printer.

After installing the Unified Linux driver, the Unified Linux Driver Configurator icon will automatically be created on your desktop.

Opening the Unified Driver Configurator

- 1 Double-click **Unified Driver Configurator** on the desktop.
You can also click the Startup Menu icon and select **Samsung Unified Driver** and then **Unified Driver Configurator**.
- 2 Press each button on the Modules pane to switch to the corresponding configuration window.

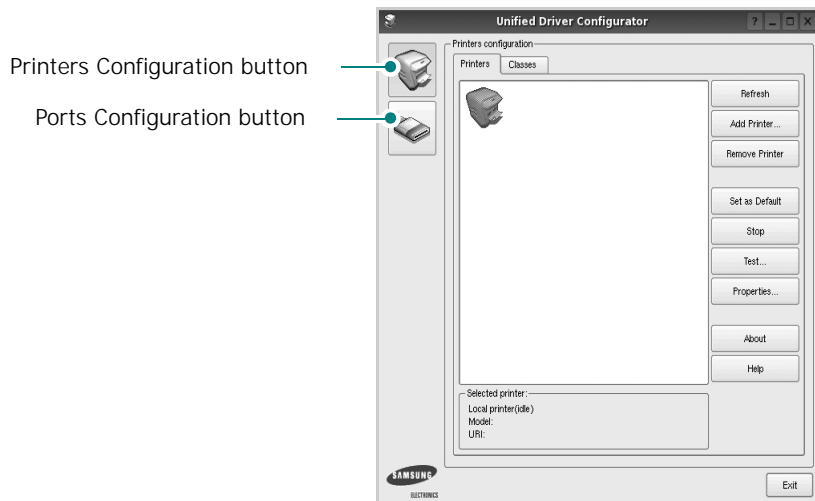

- 3 You can use the onscreen help by clicking **Help**.
After changing the configurations, click **Exit** to close the Unified Driver Configurator.

Printers Configuration

Printers configuration has the two tabs: **Printers** and **Classes**.

Printers Tab

You can see the current system's printer configuration by clicking on the printer icon button on the left side of the Unified Driver Configurator window.

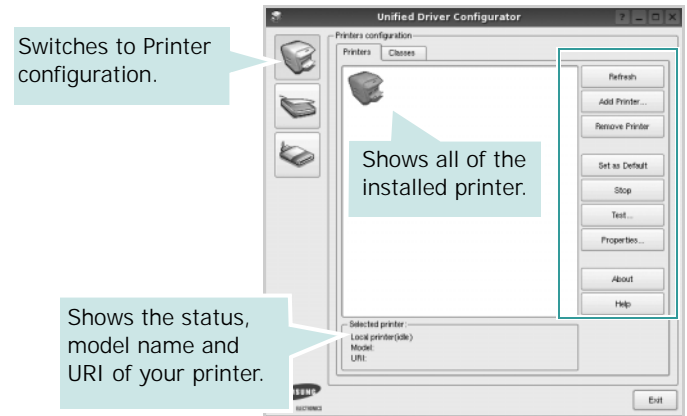

You can use the following printer control buttons:

- **Refresh:** renews the available printers list.
- **Add Printer:** allows you to add a new printer.
- **Remove Printer:** removes the selected printer.
- **Set as Default:** sets the current printer as a default printer.
- **Stop/Start:** stops/starts the printer.
- **Test:** allows you to print a test page to check if the machine is working properly.
- **Properties:** allows you to view and change the printer properties. For details, see page 31.

Classes Tab

The Classes tab shows a list of available printer classes.

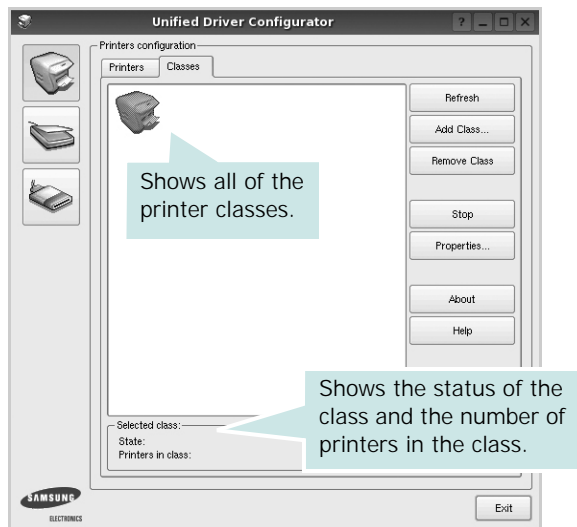

- **Refresh** : Renews the classes list.
- **Add Class...** : Allows you to add a new printer class.
- **Remove Class** : Removes the selected printer class.

Ports Configuration

In this window, you can view the list of available ports, check the status of each port and release a port that is stalled in busy state when its owner is terminated for any reason.

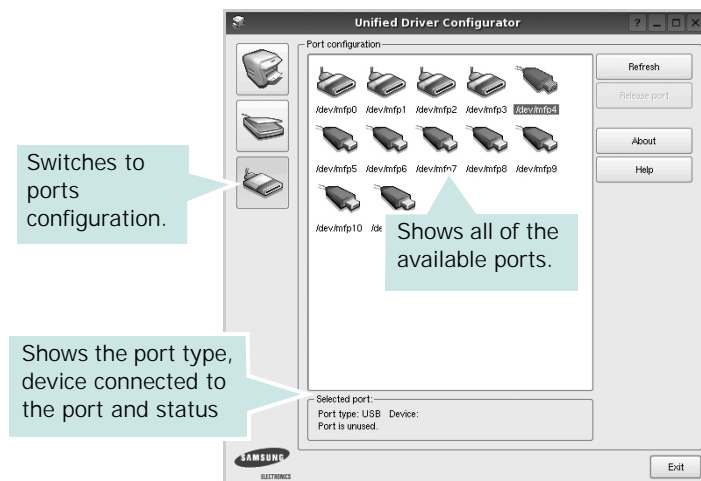

- **Refresh** : Renews the available ports list.
- **Release port** : Releases the selected port.

Configuring Printer Properties

Using the properties window provided by the Printers configuration, you can change the various properties for your machine as a printer.

- 1 Open the Unified Driver Configurator.
If necessary, switch to Printers configuration.
- 2 Select your machine on the available printers list and click **Properties**.
- 3 The Printer Properties window opens.

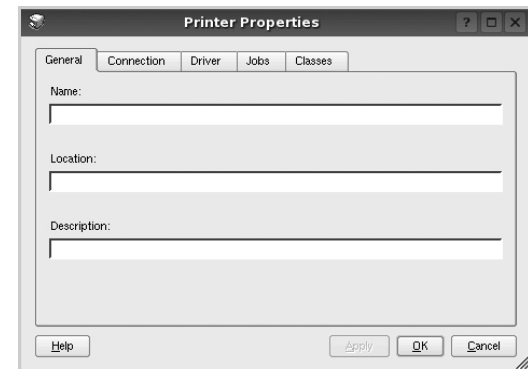

The following five tabs display at the top of the window:

- **General**: allows you to change the printer location and name. The name entered in this tab displays on the printer list in Printers configuration.
 - **Connection**: allows you to view or select another port. If you change the printer port from USB to parallel or vice versa while in use, you must re-configure the printer port in this tab.
 - **Driver**: allows you to view or select another printer driver. By clicking **Options**, you can set the default device options.
 - **Jobs**: shows the list of print jobs. Click **Cancel job** to cancel the selected job and select the **Show completed jobs** check box to see previous jobs on the job list.
 - **Classes**: shows the class that your printer is in. Click **Add to Class** to add your printer to a specific class or click **Remove from Class** to remove the printer from the selected class.
- 4 Click **OK** to apply the changes and close the Printer Properties Window.

Printing a Document

Printing from Applications

There are a lot of Linux applications that you are allowed to print from using Common UNIX Printing System (CUPS). You can print on your machine from any such application.

- 1 From the application you are using, select **Print** from the **File** menu.
- 2 Select **Print** directly using **lpr**.
- 3 In the LPR GUI window, select the model name of your machine from the Printer list and click **Properties**.

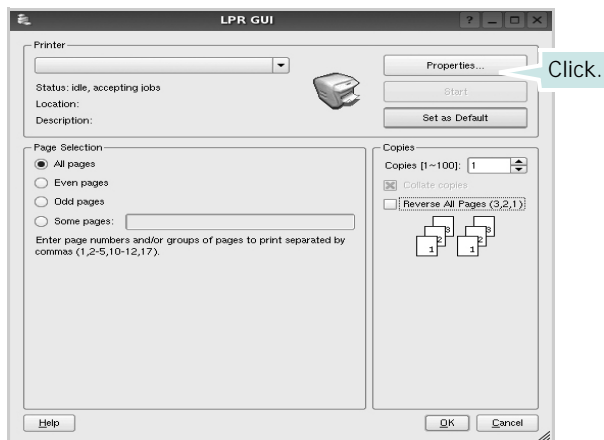

- 4 Change the printer and print job properties.

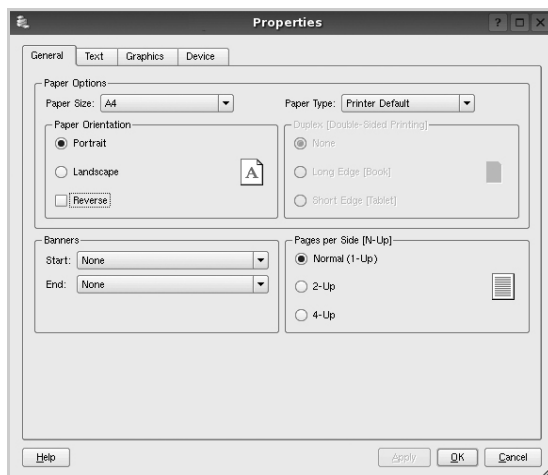

The following four tabs display at the top of the window.

- **General** - allows you to change the paper size, the paper type, and the orientation of the documents, enables the duplex feature, adds start and end banners, and changes the number of pages per sheet.
 - **Text** - allows you to specify the page margins and set the text options, such as spacing or columns.
 - **Graphics** - allows you to set image options that are used when printing images/files, such as color options, image size, or image position.
 - **Device**: allows you to set the print resolution, paper source, and destination.
- 5 Click **Apply** to apply the changes and close the Properties window.
 - 6 Click **OK** in the LPR GUI window to start printing.
 - 7 The Printing window appears, allowing you to monitor the status of your print job.
To abort the current job, click **Cancel**.

Printing Files

You can print many different types of files on the Samsung machine device using the standard CUPS way - directly from the command line interface. The CUPS `lpr` utility allows you to do that. But the drivers package replaces the standard `lpr` tool by a much more user-friendly LPR GUI program.

To print any document file:

- 1 Type `lpr <file_name>` from the Linux shell command line and press **Enter**. The LPR GUI window appears.
When you type only `lpr` and press **Enter**, the Select file(s) to print window appears first. Just select any files you want to print and click **Open**.
- 2 In the LPR GUI window, select your printer from the list, and change the printer and print job properties.
For details about the properties window, see page 32.
- 3 Click **OK** to start printing.

8 Using Your Printer with a Macintosh

Your machine supports Macintosh systems with a built-in USB interface or a 10/100 Base-TX network interface card. When you print a file from a Macintosh computer, you can use the PostScript driver by installing the PPD file.

NOTE: *Some printers do not support a network interface. Make sure that your printer supports a network interface by referring to Printer Specifications in your Printer User's Guide.*

This chapter includes:

- **Installing Software**
- **Setting Up the Printer**
- **Printing**

Installing Software

The CD-ROM that came with your printer provides you with the PPD file that allows you to use the CUPS driver or Apple LaserWriter driver (*only available when you use a printer which supports the PostScript driver*), for printing on a Macintosh computer.

Printer driver

Installing the Printer driver

- 1 Connect your machine to the computer using the USB cable or the Ethernet cable.
- 2 Turn on your computer and the machine.
- 3 Insert the PostScript driver CD-ROM which came with your machine into the CD-ROM drive.
- 4 Double-click the **Samsung_CLBP** on your Macintosh desktop.
- 5 Double-click the **MAC_Installer** folder.
- 6 Double-click the **MAC_Printer** folder.
- 7 Double-click the **Samsung CLBP Installer OSX** icon.
- 8 Click **Continue**.
- 9 Click **Install**.
- 10 After the installation is finished, click **Quit**.

Uninstalling the Printer driver

- 1 Insert the CD-ROM which came with your printer into the CD-ROM drive.
- 2 Double-click **CD-ROM icon** that appears on your Macintosh desktop.
- 3 Double-click the **Samsung_CLBP** on your Macintosh desktop.
- 4 Double-click the **MAC_Installer** folder.
- 5 Double-click the **MAC_Printer** folder.
- 6 Double-click the **Samsung CLBP Installer OSX** icon.
- 7 Select **Uninstall** and then click **Uninstall**.
- 8 Click **Continue**.
- 9 When the uninstallation is done, click **Quit**.

Setting Up the Printer

Set up for your printer will be different depending on which cable you use to connect the printer to your computer—the network cable or the USB cable.

For a Network-connected

NOTE: *Some printers do not support a network interface. Before connecting your printer, make sure that your printer supports a network interface by referring to Printer Specifications in your Printer User's Guide.*

- 1 Follow the instructions on “Installing Software” on page 33 to install the PPD files on your computer.
- 2 Open the **Applications** folder > **Utilities**, and **Printer Setup Utility**.
 - For Macintosh OS 10.5, open **System Preferences** for the **Applications** folder, and click **Printer & Fax**.
- 3 Click **Add** on the **Printer List**.
 - For Macintosh OS 10.5, press the + icon then a display window will pop up.
- 4 Select the **Bonjour (Default Browser, Default)** tab.

Then name of your machine appears on the list. Select **Samsung CLP-6xx Series (SEC000xxxxxxxx)** from the printer box, where the **xxxxxxxx** varies depending on your machine.
- 5 If Auto Select does not work properly, select **Samsung** in **Printer Model** and **your printer name** in **Model Name**.

Your machine appears on the Printer List and is set as the default printer.
- 6 Click **Add**.

For a USB-connected

- 1 Follow the instructions on “Installing Software” on page 33 to install the PPD files on your computer.
- 2 Open the Applications folder > Utilities, and **Printer Setup Utility**.
 - For Macintosh OS 10.5, open **System Preferences** for the **Applications** folder, and click **Printer & Fax**.
- 3 Click **Add** on the **Printer List**.
 - For Macintosh OS 10.5, press the + icon then a display window will pop up.
- 4 Select the **USB** tab.
 - For Macintosh OS 10.4, click **Default Browser** and find the USB connection.
 - For Macintosh OS 10.5, click **Default** and find the USB connection.
- 5 Select **your printer name**.
- 6 If Auto Select does not work properly, select **Samsung** in **Printer Model** and **your printer name** in **Model Name**.

Your machine appears on the Printer List and is set as the default printer.
- 7 Click **Add**.

Printing

NOTES:

- The Macintosh printer's properties window that appears in this User's Guide may differ depending on the printer in use. However the composition of the printer properties window is similar.
- *You can check your printer name in the supplied CD-ROM.*

Printing a Document

When you print with a Macintosh, you need to check the printer software setting in each application you use. Follow these steps to print from a Macintosh.

- 1 Open a Macintosh application and select the file you want to print.
- 2 Open the **File** menu and click **Page Setup (Document Setup** in some applications).
- 3 Choose your paper size, orientation, scaling, and other options and click **OK**.

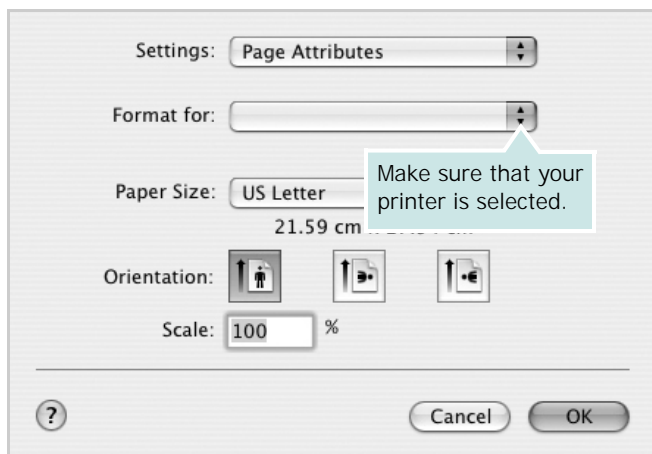

▲ Mac OS 10.3

- 4 Open the **File** menu and click **Print**.
- 5 Choose the number of copies you want and indicate which pages you want to print.
- 6 Click **Print** when you finish setting the options.

Changing Printer Settings

You can use advanced printing features when using your printer.

From your Macintosh application, select **Print** from the **File** menu. The printer name which appears in the printer properties window may differ depending on the printer in use. Except for the name, the composition of the printer properties window is similar.

NOTES:

- Note: The setting options may differ depending on printers and Macintosh OS version.

Layout

The **Layout** tab provides options to adjust how the document appears on the printed page. You can print multiple pages on one sheet of paper. Select **Layout** from the **Presets** drop-down list to access the following features.

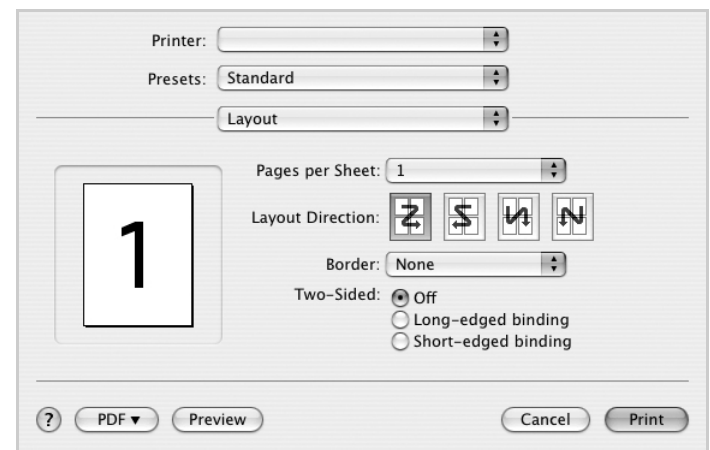

▲ Mac OS 10.4

- **Pages per Sheet:** This feature determines how many pages printed on one page. For details, see "Printing Multiple Pages on One Sheet of Paper" on the next column.
- **Layout Direction:** You can select the printing direction on a page as like the examples on UI.

Graphics

The **Graphics** tab provides options for selecting **Resolution(Quality)** and **Color Mode**. Select **Graphics** from the **Presets**' drop-down list to access the graphic features.

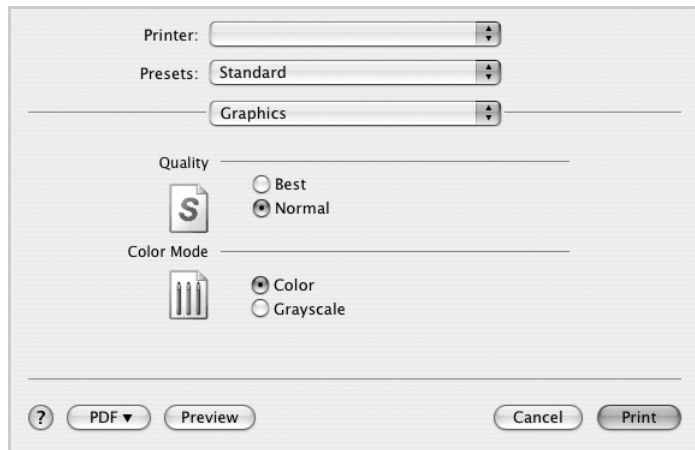

▲ Mac OS 10.4

- **Resolution(Quality)**: You can select the printing resolution. The higher the setting, the sharper the clarity of printed characters and graphics. The higher setting also may increase the time it takes to print a document.
- **Color Mode**: You can set the color options. Setting to **Color** typically produces the best possible print quality for color documents. If you want to print a color document in grayscale, select **Grayscale**.

Paper

Set **Paper Type** to correspond to the paper loaded in the tray from which you want to print. This will let you get the best quality printout. If you load a different type of print material, select the corresponding paper type.

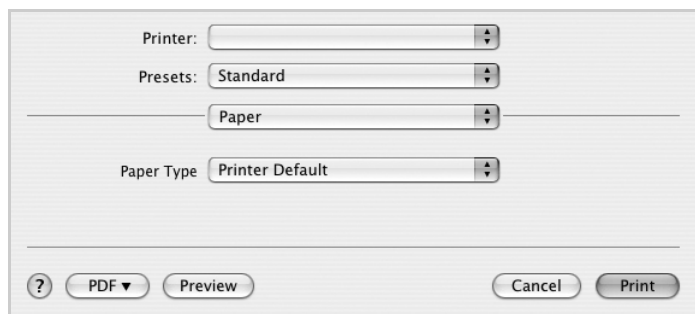

▲ Mac OS 10.4

Printer Features

This tab provides options for selecting the paper type and adjusting print quality. Select **Printer Features** from the **Presets**' drop-down list to access the following features:

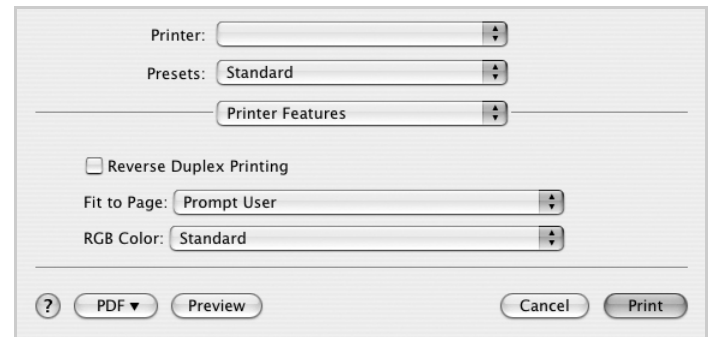

▲ Mac OS 10.4

- **Reverse Duplex Printing**: Allows you to select general print order compare to duplex print order.
- **Fit to Page**: This setting allows you to scale your print job to any selected paper size regardless of the digital document size. This can be useful when you want to check fine details on a small document.
- **RGB Color**: This setting determines how colors are rendered. **Standard** is the most widely used setting which the color tone of this mode is the closest to that of standard monitor (sRGB Monitor). **Vivid** mode is appropriate for printing presentation data and charts. The color tone of Vivid mode produces more **Vivid** color images than that of Standard mode. **Device** mode is best used for printing fine lines, small characters and color drawings. The color tone of **Device** mode may be different from that of monitor, the pure toner colors are used for printing Cyan, Magenta and Yellow colors.
- **Fine Edge**: It allows users to emphasize edges of texts and fine lines for improving readability and align each color channel registration in color printing mode.

Printing Multiple Pages on One Sheet of Paper

You can print more than one page on a single sheet of paper. This feature provides a cost-effective way to print draft pages.

- 1 From your Macintosh application, select **Print** from the **File** menu.
- 2 Select **Layout**.

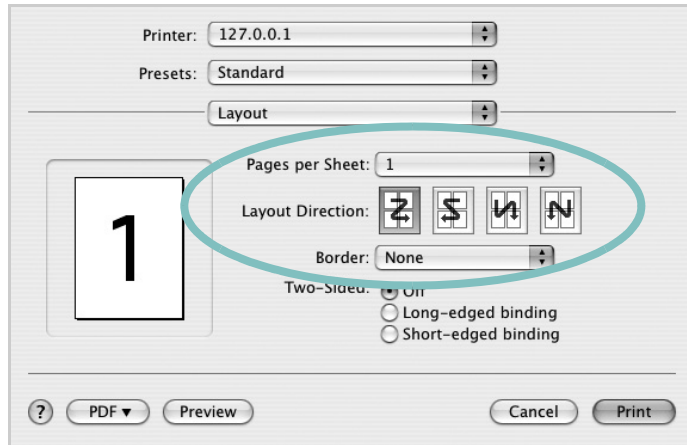

▲ Mac OS 10.3

- 3 Select the number of pages you want to print on one sheet of paper on the **Pages per Sheet** drop-down list.
- 4 Select the page order from the **Layout Direction** option.
To print a border around each page on the sheet, select the option you want from the **Border** drop-down list.
- 5 Click **Print**, and the printer prints the selected number of pages on one side of each page.

Duplex Printing

You can print on both sides of the paper. Before printing in the duplex mode, decide on which edge you will be binding your finished document. The binding options are:

Long-Edge Binding: Which is the conventional layout used in book binding.

Short-Edge Binding: Which is the type often used with calendars.

- 1 From your Macintosh application, select **Print** from the **File** menu.
- 2 Select the **Layout**.

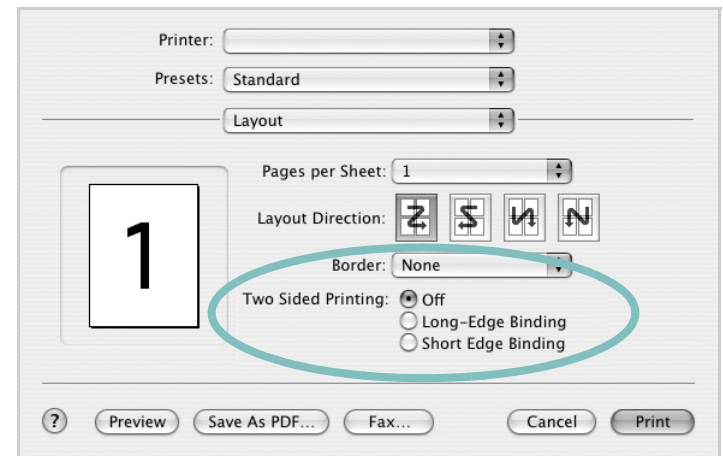

▲ Mac OS 10.3

- 3 Select a binding orientation from **Two Sided Printing** option.
- 4 Click **Print** and the printer prints on both sides of the paper.

CAUTION: If you have selected duplex printing and then try to print multiple copies of a document, the printer may not print the document in the way you want. In case of "Collated copy", if your document has odd pages, the last page of the first copy and the first page of the next copy will be printed on the front and back of one sheet. In case of "Uncollated copy", the same page will be printed on the front and back of one sheet. Therefore, if you need multiple copies of a document and you want those copies on both sides of the paper, you must print them one at a time, as separate print jobs.

SOFTWARE SECTION

INDEX

A

advanced printing, use 19

B

booklet printing 20

D

document, print
 Macintosh 35
 Windows 13

double-sided printing 21

E

Extras properties, set 17

F

favorites settings, use 18

G

Graphics properties, set 16

H

help, use 18, 24

I

install
 printer driver
 Macintosh 33
 Windows 4
installing
 Linux software 28

L

Layout properties, set
 Windows 15

Linux

 driver, install 28
 printer properties 31
 printing 32

M

Macintosh

 driver
 install 33
 uninstall 33
 printing 35
 setting up the printer 34

N

n-up printing
 Macintosh 37
 Windows 19

O

orientation, print 32
 Windows 15

overlay

 create 23
 delete 23
 print 23

P

Paper properties, set 15
paper size, set 15
 print 32
paper source, set 32
 Windows 15
paper type, set
 print 32

poster, print 20

PostScript driver
 installing 24

print

 document 13
 fit to page 21
 from Macintosh 35
 from Windows 13

 N-up

 Macintosh 37
 Windows 19

 overlay 23

 poster 22

 PRN 14

 scaling 21

 watermark 22

print resolution 32

printer driver, install

 Linux 28

printer properties

 Linux 32

printer properties, set

 Macintosh 35

 Windows 14, 24

printer resolution, set

 Windows 16

printer software

 install

 Macintosh 33

 Windows 4

 uninstall

 Macintosh 33

 Windows 11

printing

 booklets 20

 double-sided 21

 from Linux 32

R

resolution
 printing 32

S

- setting
 - darkness 16
 - favorites 18
 - image mode 16
 - resolution
 - Windows 16
 - toner save 16
 - true-type option 16
- software
 - install
 - Macintosh 33
 - Windows 4
 - reinstall
 - Windows 10
 - system requirements
 - Macintosh 33
 - uninstall
 - Macintosh 33
 - Windows 11
- status monitor, use 26

T

- toner save, set 16

U

- uninstall, software
 - Macintosh 33
 - Windows 11

W

- watermark
 - create 22
 - delete 22
 - edit 22
 - print 22

www.samsungprinter.com