

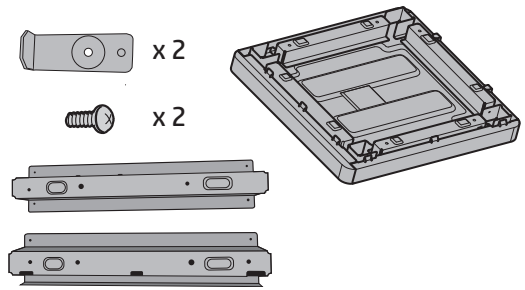

# Y1G24A HP LaserJet Spacer Installation Guide



1



Unpackage the HP LaserJet Spacer (Y1G24A), two HCl supports and retain the two "L" shaped brackets for securing the HP LaserJet spacer to the DCF or HCl.

2

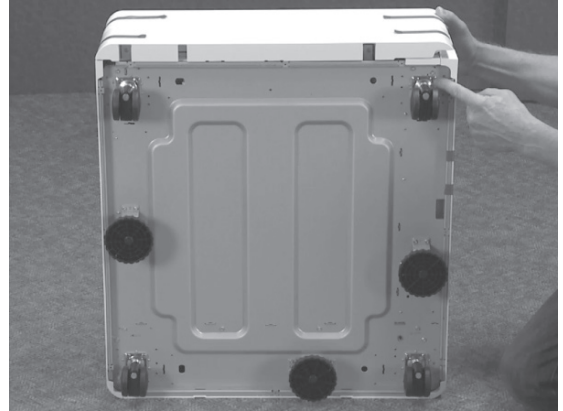

Remove the casters, stabilizer feet, and stabilizer brackets from the bottom of the DCF or HCl.

3

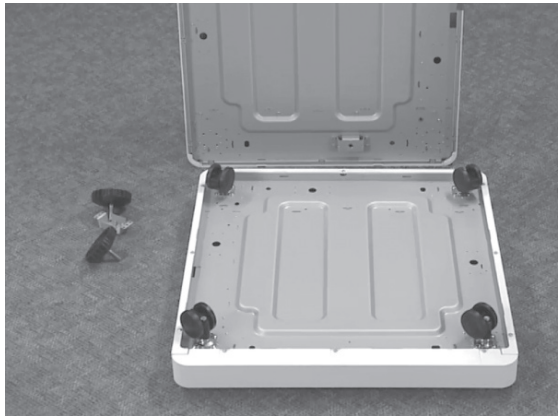

Using a manual screwdriver install the casters to the bottom of the HP LaserJet spacer. The screw holes for the casters are pre-threaded.

4



Using a manual screwdriver, install the stabilizer brackets to the bottom of the HP LaserJet Spacer. Install stabilizer feet into each bracket.

**NOTE:** The four screw holes for each stabilizer bracket are not pre-threaded. You will need to apply downward force as you install each screw.

5

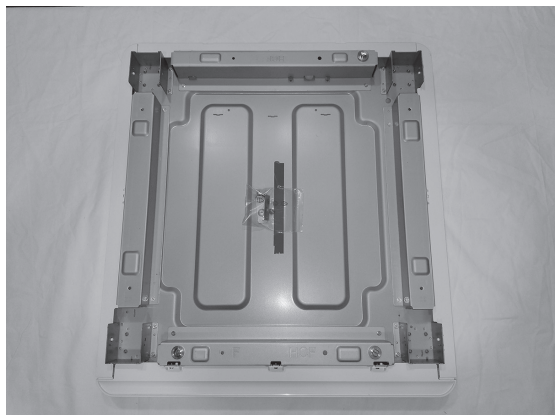

If the spacer will be installed on the HCl perform steps 6 thru 10. If installed on the DCF go to step 11.

6



Locate the two HCl supports and remove from packaging. The front and rear are clearly marked.

7

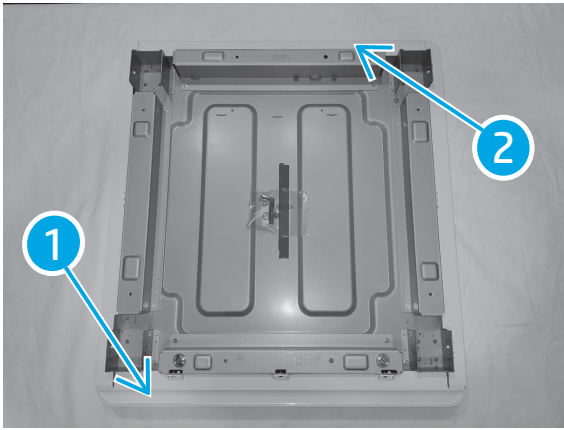

On the spacer remove six screws from the front (1) and rear (2) covers. Three are located on the outside and three more on the bottom. **NOTE:** You may need to loosen the rear side cover screws to release the rear cover.

8

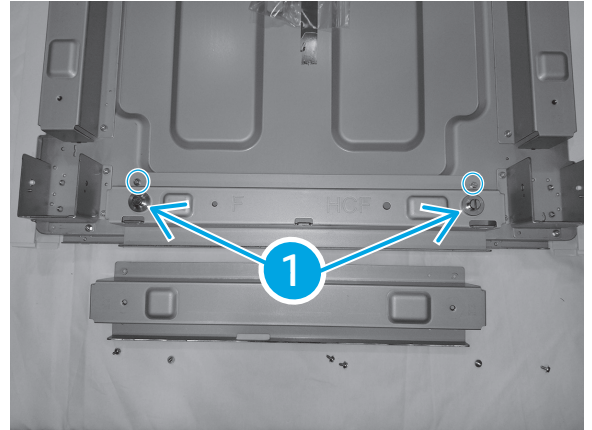

Remove two screws from the front support and remove. Install HCF front support with two screws. Move two sliver alignment pins (1) to new HCF support.

9



Remove four screws from the rear support and remove. Install HCF rear support with four screws. Move one sliver alignment pin (1) to new HCF support.

10

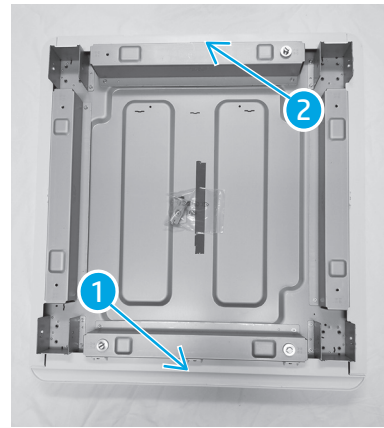

Reinstall Front and rear covers. Install four screws in each cover. If you had to loosen the side cover rear screws retighten them now.

11

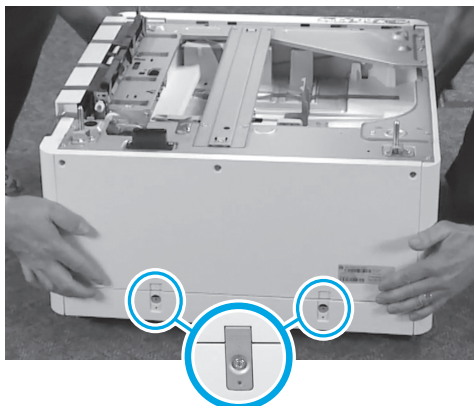

Lift and align the DCF or HCF on top of the HP LaserJet Spacer. Install two "L" shaped brackets and screws on the rear.

