

ZISA 10Gb/s BIDI SFP+

1270nm/1330nm Transceiver(V1.0)



Description

The 1270nm/1330nm 10Gb/s 40km bidirectional transceiver is designed to transmit and receive serial optical data links up from 2.5 to 10.3 Gb/s data rate over G.652 single mode fiber. The transceiver is compliant with SFF-8432, and applicable portions of SFF-8431.

Digital diagnostics functions are available via a 2-wire serial interface, as specified in SFF-8472.

Features

- Compliant to SFP+ MSA
- Fully RoHS compliant
- Operating data rate 2.5 to 10.3Gb/s
- Transmission distance up to 40km
- 1270nm/1330nm DFB laser
- LC single connector
- Hot pluggable 20pin connector
- Wide temperature range
- Low power consumption <1W
- Single +3.3V±5% power supply
- Digital monitoring SFF-8472 Rev 10 compliant
- IEEE 802.3ae 10GBASE-LR
- SFF-8431 Rev 4
- SFF-8472 Rev 10

Applications

- 10GBASE-LR/LW
- 10G Ethernet
- OBSAI rates 3.072 Gb/s,6.144Gb/s
- CPRI rates 2.4576 Gb/s,4.9152Gb/s,6.144Gb/s,9.8304 Gb/s

Specifications

(Tested under recommended operating conditions, unless otherwise noted)

Parameter	Symbol	Unit	Min	Typ	Max	Note
Optical Transmitter Characteristics						
Data Rate	-	Gbps	2.5		10.3	
Transmission Distance	L	km			40	
Center Wavelength	λ	nm	1260	1270	1280	
			1320	1330	1340	
Spectral Width(-20dB)	$\Delta\lambda_{rms}$	nm			1	1
SMSR	-	dB	30			
Optical Output Power	P _O	dBm	0		+5	2
Average Launch Power of OFF Transmitter	P _{OFF}	dBm			-30	
Extinction Ratio	ER	dB	3.5			
Relative Intensity Noise	R _{IN}	dB/Hz			-128	
Optical Output Eye	-	-	Compliant with IEEE 802.3ae			
Optical Receiver Characteristics						
Data Rate	-	Gbps	2.5		10.3	
Center Wavelength	λ_c	nm	1320	1330	1340	
			1260	1270	1280	
Receiver Sensitivity	R _{SEN}	dBm			-19	3
Receiver Overload	-	dBm	-7			3
Receiver Reflectance	R _{REFL}	dB			-26	
LOS	Optical Assert	LOS _A	dBm	-35		
	Optical Dessert	LOS _D	dBm		-20	
LOS Hysteresis	-	dB	0.5		6	
Note 1: Spectral width has to be defined over -20dBm.						
Note 2: Minimum output optical level is at end of life.						
Note 3: Sensitivity for PRBS 231-1 and BER better than or equal to 10 ⁻¹² .						

Ordering Information

Part No.	Specifications									Application
	Package	Data rate	Laser	Optical Power	Detector	Sensitivity	Temp	Reach	Others	
RTXM228-475	SFP+	2.5~10.3Gb/s	1270nm DFB	0~ +5dBm	1330nm PIN	<-19dBm	-40~85	40km	DDM	10GBASE-LR/LW OBSAI/CPRI
RTXM228-476	SFP+	2.5~10.3Gb/s	1330nm DFB	0~ +5dBm	1270nm PIN	<-19dBm	-40~85	40km	DDM	10GBASE-LR/LW OBSAI/CPRI
RTXM228-477	SFP+	2.5~10.3Gb/s	1270nm DFB	0~ +5dBm	1330nm PIN	<-19dBm	0~70	40km	DDM	10GBASE-LR/LW OBSAI/CPRI
RTXM228-478	SFP+	2.5~10.3Gb/s	1330nm DFB	0~ +5dBm	1270nm PIN	<-19dBm	0~70	40km	DDM	10GBASE-LR/LW OBSAI/CPRI

Absolute Maximum Ratings

Parameter	Symbol	Unit	Min	Max
Storage Temperature Range	Ts	oC	-40	85
Relative Humidity	RH	%	5	95
Supply Voltage	Vcc	V	-0.3	4.0

Recommended Operating Conditions

Parameter	Symbol	Unit	Min	Typ	Max
Operating Case Temperature Range	Tc	oC	-40		85
			0		70
Power Supply Voltage	Vcc	V	3.14	3.3	3.46
Bit Rate	BR	Gb/s	2.5		10.3
Bit Error Ratio	BER				10 ⁻¹²
Max Supported Link Length	L	km			40

Principle diagram

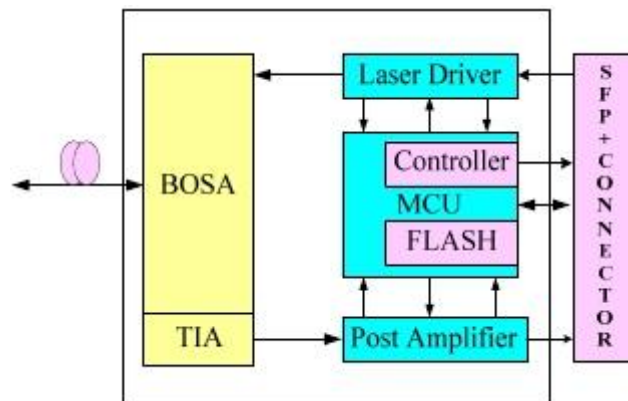

Electric Ports Definition

Parameter	Symbol	Unit	Min	Typ	Max	Notes
Supply Voltage	V _{CC}	V	3.14	3.3	3.46	
Supply Current	I _{CC}	mA			360	
Power Consumption	P _C	W			1.2	
Transmitter						
Input Differential Impedance	R _{IN}	Ω	80	100	120	1
Differential Data Input Swing	V _{IN}	mVp-p	180		700	
Transmit Disable Voltage	V _{DIS}	V	2		V _{CCHOST}	
Transmit Enable Voltage	V _{EN}	V	V _{EE} -0.3		V _{EE} +0.4	
Transmit Fault Assert Voltage	V _{FA}	V	2		V _{CCHOST}	
Transmit Fault De-Assert Voltage	V _{FDA}	V	V _{EE}		V _{EE} +0.4	
Receiver						
Differential Data Output Swing	V _{OD}	mVp-p	450	600	850	
Output Rise Time	t _{RISE}	ps	28			
Output Fall Time	t _{FALL}	ps	28			
LOS Fault	V _{LOSFT}	V	2		V _{CCHOST}	
LOS Normal	V _{LOSNR}	V	V _{EE}		V _{EE} +0.8	
NOTE 1: Differential between TD+ / TD-						

Pin Function Definitions

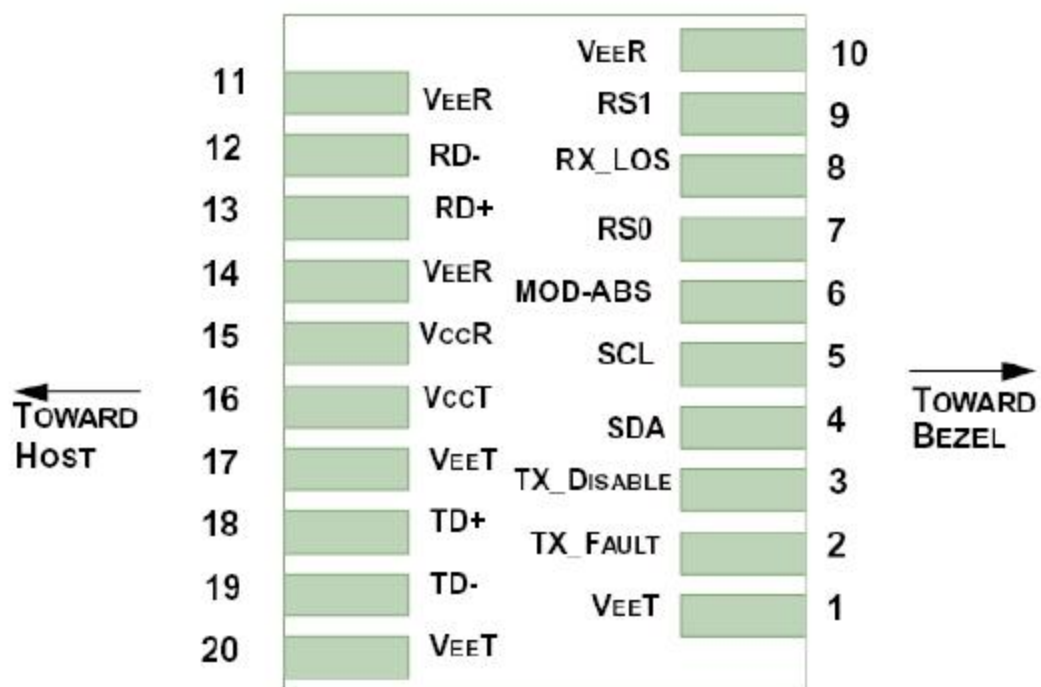

Pin Number	Symbol	Name	Description
1,17,20	VeeT	Transmitter Signal Ground	These pins should be connected to signal ground on the host board.
2	TX Fault	Transmitter Fault Out (OC)	Logic "1" Output = Laser Fault (Laser off before t_fault). Logic "0" Output = Normal Operation This pin is open collector compatible, and should be pulled up to Host Vcc with a 10kΩ resistor.
3	TX Disable	Transmitter Disable In (LVTTTL)	Logic "1" Input (or no connection) = Laser off Logic "0" Input = Laser on. This pin is internally pulled up to VccT with a 10 kΩ resistor.
4	SDA	Module Definition Identifiers	Serial ID with SFF 8472 Diagnostics Module Definition pins should be pulled up to Host Vcc with 10 kΩ resistors.
5	SCL		
6	MOD-ABS		
7	RS0	Receiver Rate Select (LVTTTL)	These pins have an internal 33kΩ pull-down to ground. A signal on either of these pins will not affect module performance.
9	RS1	Transmitter Rate Select (LVTTTL)	
8	LOS	Loss of Signal Out (OC)	Sufficient optical signal for potential BER < 1x10 ⁻¹² = Logic "0" Insufficient optical signal for potential BER < 1x10 ⁻¹² = Logic "1" This pin is open collector compatible, and should be pulled up to Host Vcc with a 10kΩ resistor.
10,11,14	VeeR	Receiver Signal Ground	These pins should be connected to signal ground on the host board.
12	RD-	Receiver Negative DATA Out (CML)	Light on = Logic "0" Output Receiver DATA output is internally AC coupled and series terminated with a 50Ω resistor.
13	RD+	Receiver Positive DATA Out (CML)	Light on = Logic "1" Output Receiver DATA output is internally AC coupled and series terminated with a 50Ω resistor.
15	VccR	Receiver Power Supply	This pin should be connected to a filtered +3.3V power supply on the host board. See Figure 3. Recommended power supply filter.
16	VccT	Transmitter Power Supply	This pin should be connected to a filtered +3.3V power supply on the host board. See Figure 3. Recommended power supply filter.
18	TD+	Transmitter Positive DATA In (CML)	Logic "1" Input = Light on Transmitter DATA inputs are internally AC coupled and terminated with a differential 100Ω resistor.
19	TD-	Transmitter Negative DATA In (CML)	Logic "0" Input = Light on Transmitter DATA inputs are internally AC coupled and terminated with a differential 100Ω resistor.

Typical Application Circuit

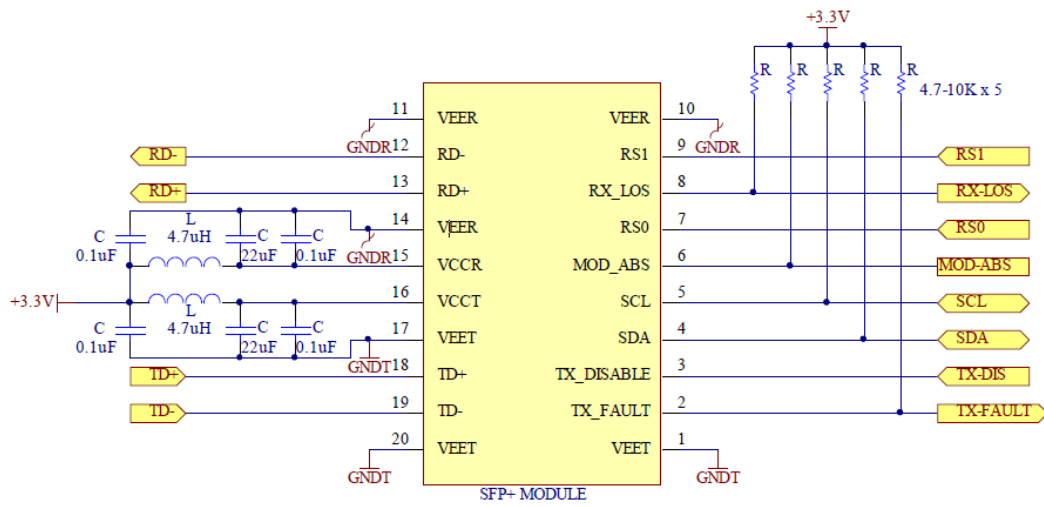

Package Outline

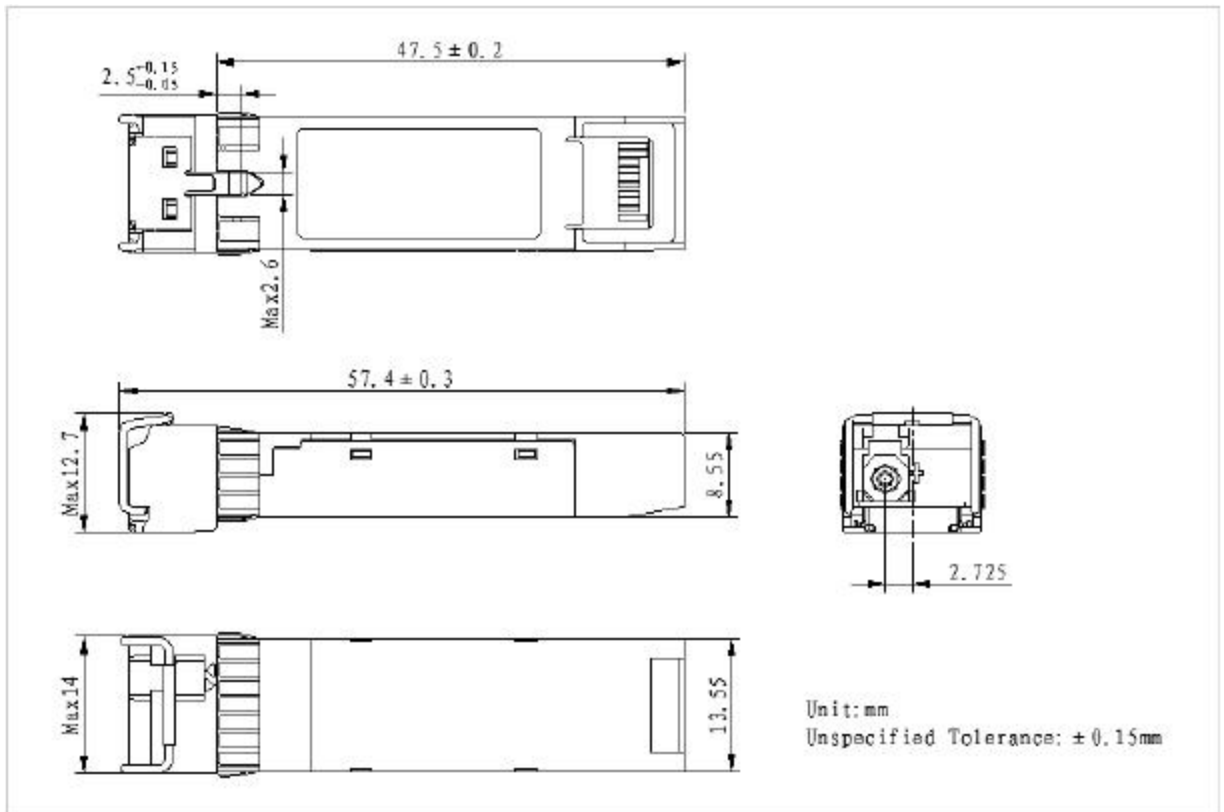

Regulatory Compliance

Feature	Test Method	Performance
Electrostatic Discharge (ESD) to the Electrical Pins	MIL-STD-883C Method 3015.4	Class1 (>1KV) for high speed I/O pins Class 1 (> 2KV) for all other pins
Electrostatic Discharge (ESD) to the Duplex LC Receptacle	Variation of IEC 61000-4-2	The BIDI SFP+ modules meet ESD requirements given in EN61000-4-2, criterion B test specification such that units are subjected to 15kV air discharges during operation and 8kV direct contact discharges to the case.
Electromagnetic Interference (EMI)	CISPR22 ITE Class B EN55022 Class B	Compliant with standards
Immunity	IEC61000-4-3 Class 2 EN55024	Typically show no measurable effect from a 3V/m field swept from 80 to 1000MHz applied to the transceiver without a chassis enclosure.
RoHS Compliance		Less than 1000 ppm of cadmium, lead, mercury, hexavalent chromium, polybrominated biphenyls, and polybrominated biphenyl ethers.

ZISA Corporation Limited

Tel: +86-10-52885062 Fax:+86-10-82156720

Mail to : sales@zisacom.com.cn

URL: <http://www.zisacom.com.cn>

Specifications are subject to change without notice.

Copyright © ZISA Corp. All rights reserved.

